



Filtration and Gas Generation Products

Bulletin FNS 1A



BALSTON®

The Parker Hannifin Filtration Group assures:

- Consistent quality
- Technical innovation
- Premier customer service

Parker's technical resources provide the right filtration technologies that conform to your requirements. That's why thousands of manufacturers and equipment users around the world rely on Parker Filtration products and people.

Worldwide Sales and Service

Parker operates sales and service centers in major industrial areas worldwide. Call 1-800-C-PARKER for more information and for a synopsis of our Filtration Technology Textbook.

Hydraulic, Lubrication & Coolant Filtration

High-performance filtration systems for production machinery in industrial, mobile and military/marine.



Compressed Air/Gas Filtration and Separation

Complete line of compressed air/gas filtration products and gas generators for many industrial and laboratory applications.



Process & Chemical Fluid Filtration

Liquid filtration systems for beverage, chemical and food processing; cosmetic, paint, water treatment; photo-processing; and micro-chip fabrication.



Fuel Conditioning & Filtration

Parker air, fuel and oil filtration systems provide quality protection for engines operating in any environment, anywhere in the world.



Legal Notifications



WARNING

FAILURE OR IMPROPER SELECTION OR IMPROPER USE OF THE PRODUCTS AND/OR SYSTEMS DESCRIBED HEREIN OR RELATED ITEMS CAN CAUSE DEATH, PERSONAL INJURY AND PROPERTY DAMAGE.

This document and other information from Parker Hannifin Corporation, its subsidiaries and authorized distributors provide product and/or system options for further investigation by users having technical expertise. It is important that you analyze all aspects of your application and review the information concerning the product or system in the current product catalog. Due to the variety of operating conditions and applications for these products or systems, the user, through its own analysis and testing, is solely responsible for making the final selection of the products and systems and assuring that all performance, safety and warning requirements of the application are met.

The products described herein, including without limitation, product features, specifications, designs, availability and pricing, are subject to change by Parker Hannifin Corporation and its subsidiaries at any time without notice.

Offer of Sale

The items described in this document are hereby offered for sale by Parker Hannifin Corporation, its subsidiaries or its authorized distributors. This offer and its acceptance are governed by the provisions stated in the "Offer of Sale".

© Copyright 1995, Parker Hannifin Corporation, All Rights Reserved.



Parker Hannifin Corporation
Filtration and Separation Division
Haverhill, MA

Table of Contents

Balston Complete Air and Gas Solutions

iv

Compressed Air Filters

1-26

Energy Saving Filter Cartridges	2
Filter Cartridge and Housing Selection	3
Flow Rates	4
International ISO Standards	5
Filter Installation Recommendations	6-8
1/4" and 1/2" Line Size Filters	9-10
3/4" to 2" Line Size Filters	11
3" to 10" Line Size Filters	12-13
Disposable Filter Silencers	14-15
Filter Regulators	16-17
Mist Lubricators	18-19
Automatic Drains - High and Normal Capacity	20
Condensate Drain - Zero Air / Zero Energy Loss	21-22
Differential Pressure Indicator Kit	23
Miniature Disposable Filter Units	24-25

Sample Filters

27-68

Energy Saving Filter Cartridges	28
Filter Cartridge and Housing Selection	29
Vapor Adsorption Cartridges	30
Stainless Steel Sintered Metal Filter	31-32
Chemical and Temperature Resistance Selection	33
Application Index	33
Flow Rates for Liquid Filters	34
Flow Rates for Air and Gas Filters	35
1/4" and 1/2" Stainless Steel In Line Filters	36
Miniature Disposable Filter Units / Nylon and PVDF Construction	37-38
High Flow Stainless Steel Filter Housings for Moderate to High Pressure Applications	39-40
High Pressure Filter Housings for High Purity, Low Flow Applications	41
Stainless Steel Filter Housings for Liquids with a High Solids content	42
Miniature Filter Housings Convenient T-Type Filters	43
Low Internal Volume Filter Housings 1/4" and 1/2" Port Size	44
High Internal Volume Filter Housings for Removing Large Volumes of Contaminants	45
1/4" to 3/4" Plastic Filter Housings	46-47
Filters for Vehicle Emission Analyzers	48

Table of Contents

Filters for Diesel Engine Analyzers	49
Series 98 Membrane Filters - Hydrophobic Membrane Protection	50-51
Series A98 Coalescer Membrane Combination Filters	52-53
Series A39/12 Coalescer Membrane Combination Filter	54-55
39 Series Membrane Filters	56-57
Fast Loop Filters	58-59
Horizontally Mounted Sample Filter	60
Sample Filter Functions	61-68
Vacuum Pump Exhaust and Inlet Filters	69-88
Exhaust Filters for Hazardous/Corrosive Applications	70-71
Vacuum Pump Exhaust Filters for Non-Hazardous/Non-Corrosive Applications	72-73
Vacuum Pump Inlet Filters for Vacuum Service to 10 ⁻⁶ Torr	74-75
Vacuum Pump Inlet Filters for Vacuum Service to 2 Torr	76-77
Recommended Exhaust Filters for Vacuum Pumps	78-86
Pump to Filter Adaptors Straight Thread to NPT Thread	87
Pump to Filter Adaptors Flange to NPT Thread	88
Balston Liquid Filters	89-98
Filter Cartridge and Housing Selection	90
Chemical and Solvent Compatibility	91
1/4" to 3/4" Line Size	92-93
1" Line Size	94
1/2" to 2" Line Size	95
Disposable Filter Units for Liquids	96-97
Water Filter	98
Filters and Air Dryers for Hospital Applications	99-110
Steam Filters for Sterilizers	100-101
Water Filters for Washer Sterilizers	102-103
EtO Filters	104
SMART Dryer™ Medical Air Dryer	105-110
Natural Gas Filters	111-116
Energy Saving Filter Cartridges	112
2" Through 4" Line Size	113-114
6" Through 10" Line Size	115
Flow Rates	116

Table of Contents

O.01 Micron Membrane Filters	117-124
0.01 Micron Membrane Filters	118-119
Disposable Filter Units	120
1/8" to 1/2" Line Size Stainless Steel or PTFE Filter Housings	121-122
1/2" Line Size High Pressure Membrane Filters	123-124
Steam and Sterile Air Filters for the Food Industry	125-138
Energy Saving Filter Cartridges	126
Steam Filters	127-128
Sterile Air Filter Cartridges and Housing Selection	129
Flow Rates for Sterile Air Filters	130
1/4" to 2" Line Size Sterile Air Filters	131-132
3" to 10" Line Size Sterile Air Filters	133-134
1/4" to 1" Line Size Steam Sterilizable Sterile Air Filters	135-136
2" to 10" Line Size Steam Sterilizable Sterile Air Filters	137-138
Nitrogen Generator Systems	139-150
Membrane Nitrogen Generators	140-144
Principal Specifications - HFX Series	143
Principal Specifications - Nitrosource Series	144
PSA Nitrogen Generators	145-150
Principal Specifications - MB Series	147
Principal Specifications - DB Series	148-150
Compressed Air Dryers	151-164
Membrane Air Dryers - Models 76-01, 76-02, 76-20, 76-40, 76-100-4050	152-155
SMART Dryer™ 5000 Series Membrane Air Dryers	156-160
Membrane Air Dryers for Coordinate Measurement Machines	161-162
PSA Air Dryers	163-164

Balston® Complete Air and Gas Solutions

Compressor Room

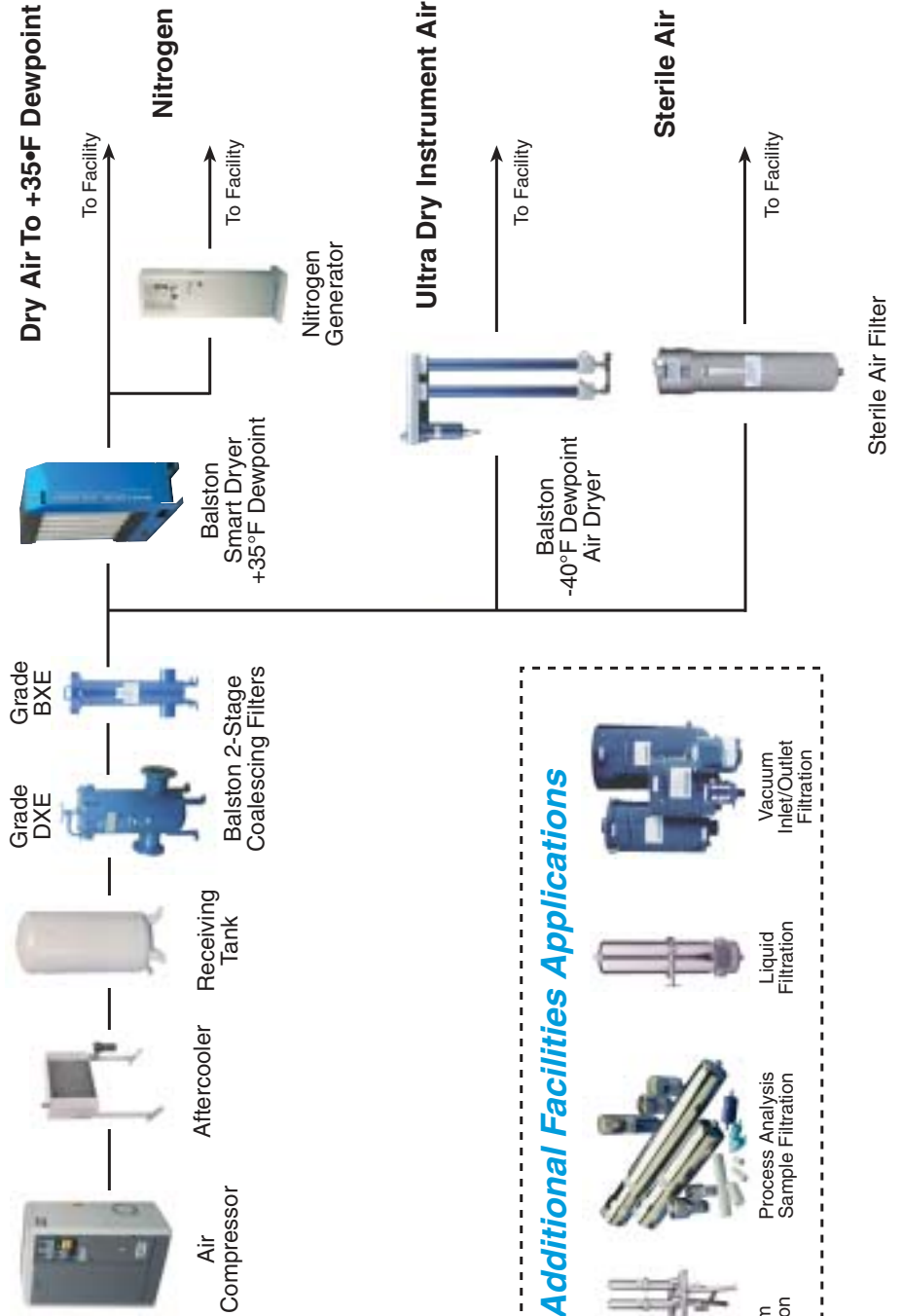

Additional Facilities Applications

- Steam Filtration
- Process Analysis Sample Filtration
- Liquid Filtration
- Vacuum Inlet/Outlet Filtration

Balston Coalescing Compressed Air Filters



*Remove 99.99% of
0.01 micron particles
of oil, water, and dirt
from compressed air
and other gases*

*Continuously trap and
drain liquids*

*Service flow ranges
from a few SCFM to
40,000 SCFM*

*Remove trace oil
vapor with adsorbent
cartridges*

*Lifetime warranty
(20 year) with select
1/4" to 2" line filters*

Balston Microfiber® Filter Assemblies

Balston Coalescing Compressed Air Filters protect your equipment and delicate instruments from the dirt, water, and oil usually found in compressed air. Balston Coalescing Filters remove these contaminants at a very high efficiency - up to 99.99% for 0.01 micron particles and droplets. Liquid releases from the filter cartridge to an automatic drain as rapidly as it enters the filter. This allows a Balston Coalescing Filter to continue removing liquids for an unlimited time without loss of efficiency or flow capacity. Select 1/4" to 2" line filters come with a lifetime (20 year) warranty which guarantees the product against defects and other failures.

NEW

from Parker Balston!

Energy Saving Filter Cartridges!

New and improved with the same filter performance you have come to expect from Balston cartridges, the new XE-Cartridges will reduce your annual operating costs!

What is creating the operating cost?

For every 2 psi of differential pressure in a compressed air system, the drive energy on the compressor is increased by 1%.
By minimizing differential pressure drop through compressed air filters, less drive energy on the compressor is realized and thus lower energy costs.

What is the savings solution?

The new XE-Cartridges from Parker Balston exhibit a 2+ psi pressure drop improvement over the current X cartridge. This produces a cost savings of \$27.00 to \$240.00 per year per installed filter cartridge depending on the number of work shifts.*

How do I order them?

For your next order of filter cartridge replacements be sure to order the NEW XE-Cartridges! Just simply add an "E" for energy savings to the end of the part number! See example below.

Current Part #	New Part #
100-18-DX	100-18-DXE

Now is the time to outfit your entire facility with the
NEW Parker Balston XE-Cartridge!

**If you have any questions please feel free to call us at
800-343-4048 and ask for Technical Services Department.**

*based on \$0.07 Kwh as a national average electrical cost. Savings are more significant in higher cost regions!



Filter Cartridge Description

General purpose applications such as plant compressed air	Single stage filtration. Use a Grade DXE filter cartridge
Instrument air and other critical air requirements	Two stage filtration is necessary. Use a Grade DXE followed by a Grade BXE filter cartridge. As a general rule, a Grade BXE filter cartridge should not be used alone.
Removal of trace compressor oil vapor	For rare instances where even a trace amount of oil vapor can cause a problem, three stage filtration is necessary. Use a Grade DXE followed by a Grade BXE, and a type CI cartridge.

Physical Properties, Microfibre Filter Cartridges

Temperature Range	-150°F to 300°F (-100°C - 149°C)
Maximum Pressure Differential Across Filter, Inside-to-Outside Flow:	100 psi
Materials of Construction	Borosilicate glass microfibers with fluorocarbon resin binder. Resistant to water, all hydrocarbon and synthetic lubricants.

Retention Efficiency

Grade	Efficiency for 0.01 Micron Particles and Droplets
DXE	93%
BXE	99.99%

Balston Filter Cartridges

Balston provides two grades of coalescing filter cartridges, Grade DXE and Grade BXE. Singly or in tandem, these filters satisfy all requirements for removing liquid and solid contaminants from compressed air. Balston also has an activated carbon adsorbent CI-type cartridge for the removal of trace oil vapors from a compressed air line. The activated carbon cartridge is Grade 000.

How to Select the Filter Cartridge and Housing

- 1 Decide which grade(s) of filter cartridges fits the application (see selection boxes at left).
- 2 Select the filter housing with a port size equal to the line size where the filter is to be located.
- 3 For a new installation in which the line size has yet to be selected, determine the gas flow rate and pressure at the point where the filter will be located, and then refer to the flow chart on the reverse side of this data sheet. NOTE: The filter port size must be equal to or larger than the line size (when specified).

How to Order the Filter Assembly

- 1 Build your own custom filter assembly using the guideline matrix on Page 8 and specify your model number. Example: 1/2" filter with DPI and Auto Drain with Grade DXE Filter = 2104N-1B1-DX
- 2 Each assembly is shipped with the filter cartridge installed. To order additional filter cartridges, indicate the model number of the cartridges, and the grade. Examples 050-05-DXE, 050-05-BXE. The grade used for Type CI cartridges is 000 (CI-100-12-000).

Note: Assemblies with CI Cartridges are shipped with the adsorbent cartridge wrapped separately. This shipping method prolongs the life of the cartridge.



Flow Rates

Filter Housing Model	Port Size	Filter Cartridge Grade	Flow rates (SCFM), at 2 psi drop at indicated line pressure. Refer to Principal Specification Charts in each product data sheet for maximum pressure rating of each housing										
			2	20	40	80	100	125	150	200	250	400	650
A94A	1/4"	DXE	4	9	13	24	29	36	43	55	67	—	—
A914, A914D, A914P		BXE	1.2	2.4	4	7	8	9	12	15	17	—	—
2002	1/4"	DXE	9	19	39	51	63	76	90	117	145	—	—
2003	3/8"	BXE	3	8	11	21	25	31	36	47	58	—	—
2004	1/2"	CI	2	5	7	12	15	18	22	28	35	—	—
2104	1/2"	DXE	19	41	65	113	137	166	196	257	316	—	—
		BXE	9	19	30	51	63	76	90	117	145	—	—
		CI	6	12	19	32	39	48	56	73	90	—	—
2206	3/4"	DXE	37	78	123	214	259	315	371	484	596	—	—
		BXE	10	21	34	56	70	85	101	131	162	—	—
		CI	8	16	26	44	53	65	76	99	122	—	—
2208	1"	DXE	55	115	181	314	380	463	546	711	877	—	—
		BXE	11	23	37	64	77	94	111	144	178	—	—
		CI	10	20	32	56	67	82	96	125	154	—	—
2312	1 1/2"	DXE	98	203	319	554	670	816	963	1254	1546	—	—
		BXE	22	46	74	129	155	189	223	290	358	—	—
		CI	16	33	52	91	110	134	158	206	253	—	—
A15/80	2"	DXE	160	333	525	908	1100	1340	1580	2060	2540	—	—
		BXE	45	94	148	256	310	378	445	580	715	—	—
		CI	23	49	77	133	161	197	231	301	371	—	—
AKN-0280 AKC-0280 AKH-0280	3"	DXE	364	760	1190	2060	2500	3045	3600	4680	5770	9030	14480
		BXE	90	190	300	510	620	755	890	1160	1430	2240	3590
		CI	47	98	154	266	322	394	462	602	742	1160	1860
AKC-0480 AKH-0480	4"	DXE	740	1540	2430	4210	5100	6210	7300	9550	11750	18400	29480
		BXE	180	380	590	1020	1240	1510	1780	2320	2860	4480	7180
		CI	94	196	308	632	644	780	920	1200	1480	2320	3710
AKC-0880 AKH-0880	6"	DXE	1500	3120	4910	8500	10300	12550	14800	19300	23700	37120	59460
		BXE	360	750	1180	2050	2480	3020	3560	4640	5710	8940	14330
		CI	188	392	616	1064	1280	1560	1840	2390	2950	4620	7400
AKC-1480 AKH-1480	8"	DXE	2620	5450	8580	14860	18000	21900	25800	33700	41540	65050	104200
		BXE	630	1310	2070	3580	4340	5300	6230	8120	10010	15680	25100
		CI	329	686	1078	1860	2250	2740	3230	4210	5190	8130	13020
AKC-2280 AKH-2280	10"	DXE	4080	8470	13350	23110	28000	34100	40200	52400	64590	101150	162050
		BXE	1000	2070	3270	5660	6850	8340	9840	12800	15780	24700	39600
		CI	516	1077	1690	2920	3540	4310	5070	6610	8150	12760	20450

Table taken from ISO8573 - 1

Class	Solid		Water		Oil	
	Maximum Particle Size (µm)	Maximum Concentration ppm (mg/m ³)	Maximum Pressure Dewpoint °F (°C)	Maximum Pressure Dewpoint °F (°C)	Maximum Concentration ppm (mg/m ³)	Maximum Concentration ppm (mg/m ³)
1	0.1	.08 (0.1)	-94 (-70)	-94 (-70)	.008 (0.01)	.008 (0.01)
2	1	.8 (1)	-40 (-40)	-40 (-40)	.08 (0.1)	.08 (0.1)
3	5	4.2 (5)	-4 (-20)	-4 (-20)	.83 (1)	.83 (1)
4	15	6.7 (8)	37 (+3)	37 (+3)	4.2 (5)	4.2 (5)
5	40	8.3 (10)	45 (+7)	45 (+7)	21 (25)	21 (25)
6	-	-	50 (+10)	50 (+10)	-	-

ISO Class Example 1 Solid 4 Water 1 Oil

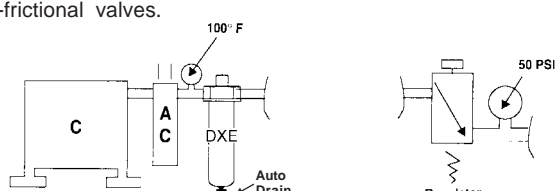
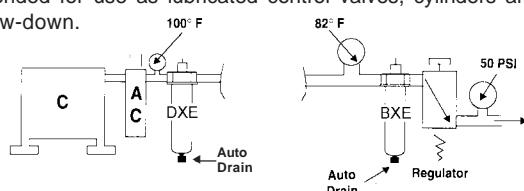
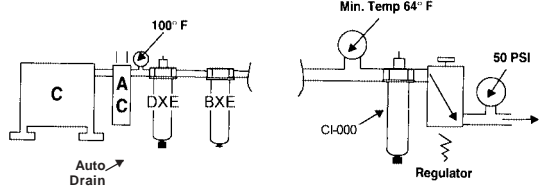
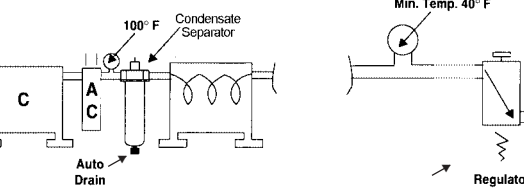
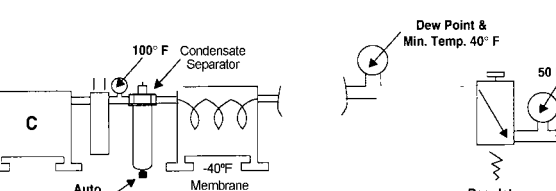
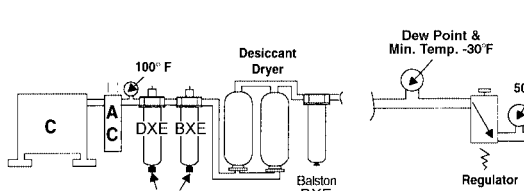
<p>ISO Class 2 2</p> <p>Any compressor with aftercooler and coalescer. Air intended for use with lubricated air tools, air motors, cylinders, shot blasting, non-frictional valves.</p>  <p>ADDITIONAL SPECS: CGA - G7.1 (Grades A & Ba1)</p>	<p>ISO Class 1 1</p> <p>Any compressor with aftercooler and 2-stage coalescing. Air intended for use as lubricated control valves, cylinders and parts blow-down.</p>  <p>ADDITIONAL SPECS: Mil. Std. 282 H.E.P.A., U.S.P.H.S. 3A accepted particles for milk.</p>
<p>ISO Class 1 1</p> <p>Any compressor with aftercooler, 2-stage coalescing and activated carbon filter. Air intended for use with general pneumatics systems.</p>  <p>ADDITIONAL SPECS: CGA - G7.1 (Grade C)</p>	<p>ISO Class 1 4 1</p> <p>Any compressor with aftercooler, 2-stage coalescing and refrigerated dryer for use with instrument quality air.</p>  <p>ADDITIONAL SPECS: CGA - G7.1 (Grade D & E) ISA S7.3, Fed. Std. 209 (Class 100)</p>
<p>ISO Class 1 2 1</p> <p>Any compressor with aftercooler, 2-stage coalescing, and a -40°F membrane air dryer. Air intended for use as industrial breathing air and decompression chambers.*</p>  <p>ADDITIONAL SPECS: O.S.H.A. 29CFR 1910.134 *CO Monitor required.</p>	<p>ISO Class 1 1 1</p> <p>Any 2-stage compressor with aftercooler, double coalescing and a regenerative-type desiccant dryer. Air intended for use in applications involving critical instrumentation and high purity gases.</p>  <p>ADDITIONAL SPECS: CGA - G7.1 (Grade F)</p>

Note: In the pictorial examples shown above, the contribution of hydrocarbon vapors has not been taken into account in determining the OIL class category.

Recommendations for Typical Filter Installations

Selecting the proper location for a filter in a compressed air line is as important as selecting the proper filter. In most cases you will probably be able to base your own installation on these recommendations for typical installations.

Placing the Filter at the Compressor

The standard compressor installation consists of a prefilter (mounted on the compressor), a compressor, aftercooler, and a receiver. The Balston filter should be installed downstream from the receiver. In a system with an efficient aftercooler, the distance from the receiver to the filter is not important. Since the filter is usually maintained by the personnel responsible for the compressor, it is often convenient to install the filter downstream from the receiver. If there is no aftercooler, or the aftercooler is not efficient, coalescing filter be installed as close to the point(s) of use as possible.

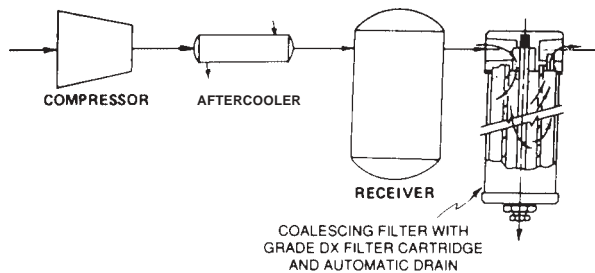

Compressor Filter Specifications

Microfibre Filter Cartridge	Grade DXE
Filter Housing	Determine filter size from flow chart on page 3, but port size must be equal to or larger than the line size
Automatic Drain	Recommended
Differential Pressure Indicator	Recommended

Some compressor installations do not have an aftercooler (this is an undesirable situation). Air saturated with water vapor leaves a compressor at 240°F to 400°F (116°C to 204°C). Without an aftercooler, the air cools close to room temperature in the distribution lines and water condenses throughout the air distribution system. About two-thirds of the total water content of the air will be condensed when the air has cooled to 100°F

(38°C). A filter located just before the main air line branches into smaller distribution lines will remove most of the water load from the system. The filter requirements for the main line are described above; they are the same as for a system with an aftercooler. However, since the air will continue to cool in the distribution system, additional filters located at end-use points will be required to remove water condensed downstream from the main line filter.

How to Obtain a Trouble-Free Coalescer

The mechanism of coalescing leads to three important considerations in selecting and installing a coalescing filter:

- 1 The filter should be large enough to ensure that the air exits the filter at low velocity and does not carry over coalesced liquid. Proper sizing of a Balston coalescing filter is easily done by using the recommendations or the maximum flow rate data. There is no danger on oversizing the filter. A Balston coalescing filter is even more efficient at extremely low flow rates than at its maximum rated flow capacity.
- 2 To avoid liquid carryover, the coalesced liquid should not be allowed to build up in the filter housing above the level of the bottom of the filter tube.

Rather than relying on operator attention to this easily-overlooked job, Parker Hannifin Corp. recommends automatic drains with all coalescing filters.
- 3 The flow direction through the Microfibre filter tube must be inside-to-outside to permit the liquid to drip from the outside of the tube to the drain in the filter housing. If installed outside-to-inside, the filter will at first function as a coalescing filter, but liquid will collect on the inside of the filter tube. Since there is no way of draining the liquid, the level will build up rapidly until it begins to be carried downstream by the air flow. The filter will work at removing liquids for a short time, and then not work at all. If the Balston coalescing filter exhibits these symptoms, reversing the flow direction will solve the problem.



Removing Oil from Compressed Air

The source of oil in compressed air is the compressor lubricant. The common plant problems resulting from oil in the air are caused by liquid oil depositing in valves, instrument control surfaces, and other critical points in the air distribution system.

Balston often receives inquiries from users of compressed air about removing oil vapor from the air, yet the only reason for concern about oil vapor in most applications is that it may condense to liquid oil. Just like water vapor, oil vapor will condense to liquid when the temperature is reduced or the air pressure is increased at constant temperature. However, the table below shows that while in theory, condensation of oil vapor and water vapor are similar, in practice the effect of condensation of the two vapors is quite different.

Concentration of vapor, parts per million by weight (ppm) in air at 100 psig, at indicated temperature			
	Petroleum Base Oil	Synthetic Oil	Water
80°F	0.012	0.002	2,743.
100°F	0.05	0.01	5,137.
125°F	0.2	0.06	10,508.
150°F	0.7	0.2	20,119.
200°F	3.5	2.4	62,371.

From the above figures, one can calculate that if 100 SCFM of air is filtered at 125°F to remove all liquids, and is subsequently cooled to 80°F, condensed liquids would consist of: water 3.6 lbs per hour, and either petroleum base oil 0.001 lbs. per hour, or synthetic oil 0.0003 lbs per hour. Condensed water is potentially a serious problem, but the quantity of condensed oil vapor is extremely small.

Field tests show that the liquid oil in air from a well-maintained reciprocating compressor is typically in the range of 15 to 30 ppm. With an oil-sealed rotary screw compressor, liquid oil content in the compressed air can vary from 10 to more than 100 ppm, depending upon the efficiency of the bulk oil separator. Compared to these figures, the approximate 0.2 ppm of liquid oil which could result from oil vapor condensation is for practical purposes negligible.

Therefore, removing the liquid oil from compressed air with a Balston coalescing filter, even at temperatures as high as 125°F, will eliminate the chance of oil-caused problems downstream in virtually all installations.

There are rare instances in which even 0.2 ppm oil vapor in the air or gas can cause a problem; for example, in

contact with a sensitive catalyst or other highly reactive material.

In those cases, the trace quantity of oil vapor can be reduced using an adsorbent-loaded cartridge, following coalescing filter to remove the liquid oil.

Placing the Filter at the Point-Of-Use

Whether or not the system has an aftercooler, Balston strongly recommends a filter at each critical end-use point, even if a main line Grade DXE filter has been used. The point-of-use filters will remove dirt and oil which may have been in the distribution lines, as well as water that has condensed downstream from the main filter. If there is a pressure regulator at the end-use point, the filter should be installed immediately upstream from the regulator. Alternatively, replace the existing regulator with a combination Balston filter-regulator.

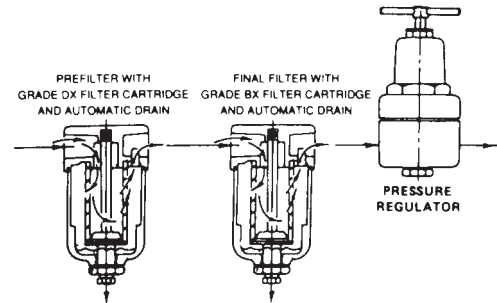

Point-of-Use Filter Recommendations

Microfibre Filter Cartridge	Grade BXE
Filter Housing	Size from flow chart or by line size
Automatic Drain	Recommended (refer to Page 18)

If there is no Grade DXE filter upstream from the final filter, or if a significant amount of water or oil is expected, then a two-stage system, Grade DXE followed by Grade BXE, is required at each use point. The housing and automatic drain for the Grade DXE prefilter should be the same as for the Grade BXE final filter (if the flow capacities permit).

Even if the application is not particularly sensitive to impurities in the air - for example, an air-driven tool - it is still good practice to remove condensed water with a filter at the end of the line. Balston recommends a single-stage Grade DXE filter with automatic drain.

Using Filters With Air Dryers

Properly specified filters are relatively inexpensive protection for air dryers. Both refrigerated and desiccant dryers benefit from filter protection.

Refrigerated Dryers

A Grade DXE prefilter with automatic drain should be installed upstream from a refrigerated dryer to prevent oil and condensed water from entering the dryer. Oil entering a dryer coats the cooling coil and reduces its efficiency; condensed water increases the cooling load and reduces dryer capacity. A dryer that was in operation before a Balston filter was installed may already have oil inside it. Therefore a second filter, a Grade BXE filter with automatic drain, must be installed downstream from the dryer if oil-free air is required.

Desiccant Dryers

Desiccant dryers are very sensitive to water and oil droplets. Water can saturate the desiccant and reduce its drying efficiency or even destroy it. Oil can coat the desiccant, rendering it ineffective, or the oil can accumulate on the desiccant and create a combustion hazard when the desiccant is heated for regeneration.

For maximum protection of the desiccant dryer, a two-stage filter (Grade DXE followed by Grade BXE) system with automatic drains should be installed upstream from the dryer. To protect downstream delivery points from abrasive desiccant particles, a high efficiency filter with high solids holding capacity should be installed downstream from the dryer. The Balston Grade DXE filter cartridge is recommended for this downstream installation location. (Note: All Balston desiccant dryers are equipped with prefilters and final filters, as recommended above).

Membrane Dryers

Membrane air dryers are sensitive to water and oil droplets. Oil can permanently damage the hollow fiber core. Balston Membrane Air Dryers are assembled with maximum protection, two stage coalescing filters (Grade DXE followed by BXE) designed to remove all contaminants down to 0.01 microns. Most all other membrane dryers are not assembled with adequate prefiltration protection and should be protected with a two stage Balston Filter System (Grade DXE, Grade BXE).

Maintaining The Filters

In a typical compressed air delivery system, a properly specified Balston filter cartridge can be expected to last for one year. The filter cartridge can continue to coalesce indefinitely, but solids loading in the depth of the cartridge will cause a pressure drop through the housing. The filter should be changed when the pressure drop reaches 10 psi. At pressure drops higher than 10 psig, the cartridge will continue to perform at its rated efficiency, but downstream instrumentation may be affected by the pressure drop.

To monitor the condition of the filters, install Balston Differential Pressure Indicators (DPI) on the filters or across a multi-filter installation. The DPI gives a visual indication of differential pressure through the filter cartridge. The Balston Differential Pressure Indicator is factory-installed on 1/4" and larger line size Balston Compressed Air Filter Assemblies. To use a DPI with a smaller Balston Compressed Air Filter, pressure taps must be provided with "tees" on the line upstream and downstream from the filter.



Models A914D, A914P, A914, A914A

Models A914P and A914D are 1/4" line size assemblies with simple, reliable "automatic" drains used for low flow applications with moderate levels of liquid contaminate. The A914P is designed to empty condensate when there is a sudden pressure drop through the system (intermittent compressed air demand applications). The A914D incorporates an overnight drain which will drain liquid contaminate when the compressed air system pressure drops below 5 psig. The standard A914 utilizes a standard manual threaded drain. All models have a transparent polycarbonate bowl with an aluminum head. The Model A914A has a zinc bowl.



Model A914D, A914P, A914



Model A914A

Models 2002, 2003, and 2004

Models 2002 and 2003 are 1/4" and 3/8" line size assemblies. These filters have increased liquid holding capacity and are equipped with high capacity float drains, differential pressure indicators, sightglass, pressure relief valve, and 1/4 turn bayonet bowl closures. The 2004 series is designed to service 1/2" compressed air lines with low flow rates.

Model 2104

The Model 2104 is a 1/2" line size assembly with an aluminum bowl. The filter housing has a large liquid holding capacity and a high capacity float drain, differential pressure indicator, sightglass, pressure relief valve, and 1/4 turn bayonet bowl closure.



Model 200X Series



Model 2104 Series

Principal Specifications				
Model	A914	A914A	2002, 2003, 2004 (1)	2104 (1)
Port Size	1/4" NPT	1/4" NPT	1/4", 3/8", 1/2" NPT	1/2" NPT
Materials of Construction				
Head	Anod. Alum.	Anod. Alum.	Anod. Alum.	Anod. Alum.
Bowl	Polycarbonate	Zinc	Anod. Alum.	Anod. Alum.
Internals	Nylon	Nylon	Nylon	Nylon
Seals	Buna-N	Buna-N	Buna-N	Buna-N
Maximum Temperature	120°F (49°C)	220°F (104°C)	130°F (54°C) (2)	130°F (54°C) (2)
Maximum Pressure (3)	150 psig	250 psig	250 psig	250 psig
Minimum Pressure (4)	5 psig	5 psig	15 psig	15 psig (4)
Shipping Weight	0.5 lbs. (0.2 kg)	0.5 lbs. (0.2 kg)	2.0 lbs. (0.9 kg)	2.5 lbs. (1.1 kg)
Dimensions	1.5"W X 4.0"L (4cm X 10cm)	1.5"W x 4.0"L (4cm X 10cm)	3.3"W X 8.5"L (8cm X 20cm)	3.3"W X 11.3"L (8cm X 28cm)

Ordering Information				
For assistance, call toll-free at 1-800-343-4048 8AM to 5PM Eastern Time				
Model	A914	A914A (8)	2002, 2003, 2004 (1)	2104 (1)
Differential Pressure Indicator (7)	Not Included	Not Included	Included	Included
Replacement Filter Cartridges				
No. Required	1	1	1	1
Box of 5 (5)	5/050-05-□	5/050-05-□	5/100-12-□	5/100-18-□
Cartridges Box of 10 (5)	050-05-□	050-05-□	100-12-□	100-18-□
CI Cartridge				
Box of 1 (5)	---	---	CI-100-12-000	CI-100-25-000

- Notes:
- 1 Lifetime (20 year) Warranty included. Contact your local representative for details.
 - 2 Automatic drain and Differential Pressure Indicator are temperature limiting factors. For Temperature capabilities to 220°F (104°C), order assemblies without automatic Drain and Differential Pressure Indicator.
 - 3 Maximum pressure ratings are for temperatures to 130°F (54°C). Please consult factory for maximum pressure ratings at elevated temperatures.
 - 4 Required for proper operation of piston drain, overnight drain, or float drain.
 - 5 Indicate grade of filter cartridge by putting appropriate letter after ordering number. To order assembly with Type CI cartridges, add-000 after assembly number. Example: 2104N-0A0-000
 - 6 Automatic drains not supplied with assemblies containing Type CI cartridges.
 - 7 Differential Pressure Indicator (DPI) Kit may be ordered separately, P/N 41-071. DPI is sensitive in the range of 0-7 psi differential.
 - 8 Order A914D-_X for overnight drain installed in the filter assembly.
Order A914P-_X for piston drain installed in the filter assembly.
Order A914A-_X for aluminum bowl and 250 psig rating.

How to Order the Filter Assembly*

Build your own custom filter assembly using the guideline matrix below and specify your model number. Example: 1/2" filter with DPI and Auto Drain with Grade DXE Filter = 2104N-1B1-DX.

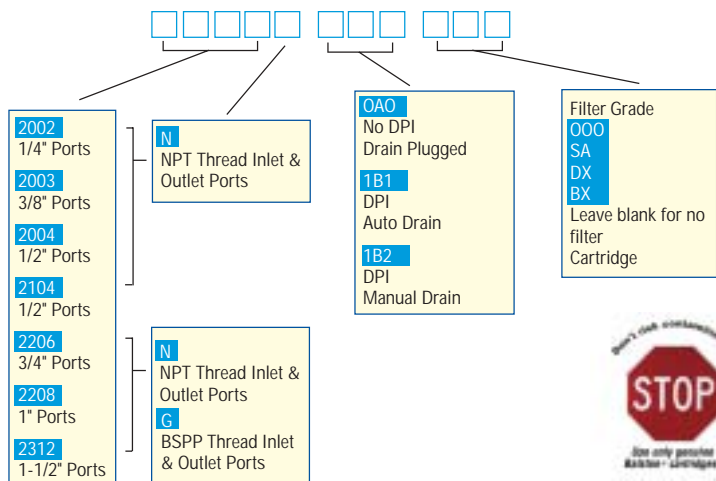

*Consult Factory. Not all configurations are available.

Models 2206, 2208, 2312, and A15/80

The Model A15/80 filter assembly has 2" NPT inlet and outlet ports, an automatic float drain and differential pressure indicator installed. The Models 2206, 2208, and 2312 filter assemblies have 3/4", 1", and 1 1/2" NPT inlet and outlet ports, respectively; these models are also equipped with automatic drains, sight glasses, pressure relief valve, bayonet closures, and differential pressure indicators. Materials of construction are shown below.



Model A15/80



Model 2312N



Model 2206N

Principal Specifications				
Model	2206	2208	2312	A15/80 (1)
Port Size	3/4" NPT	1" NPT	1 1/2" NPT	2" NPT
Materials of Construction				
Head	Anod. Alum.	Anod. Alum.	Anod. Alum.	Anod. Alum.
Bowl	Anod. Alum.	Anod. Alum.	Anod. Alum.	Steel
Internals	Nylon	Nylon	Nylon	St. Steel
Seals	Nylon	Nylon	Nylon	Buna-N
Maximum Temperature (2)	130°F (54°C)	130°F (54°C)	130°F (54°C)	130°F (54°C)
Maximum Pressure (3)	250 psig	250 psig	250 psig	250 psig
Minimum Pressure (4)	15 psig	15 psig	15 psig	15 psig
Shipping Weight	8 lbs. (3.6 kg)	8 lbs. (3.6 kg)	15 lbs. (6.8 kg)	11 lbs. (5 kg)
Dimensions	4"W X 13"L (10cm X 33cm)	4"W X 13"L (10cm X 33cm)	5.0"W X 17"L (13cm X 43cm)	6.3"W X 28"L (16cm X 71cm)

Notes:

- 1 Lifetime (20 year) Warranty included. Contact your local representative for details.
- 2 Automatic Drain and Differential Pressure Indicator are limiting factors. For temperature capabilities to 220°F (104°C), order assemblies without Auto Drain and Differential Pressure Indicator.
- 3 Maximum pressure ratings are for temperatures to 130°F (54°C). Please consult factory for maximum pressure ratings at elevated temperatures.
- 4 Required for proper operation of the float drain.
- 5 Indicate grade of filter cartridge by putting appropriate letter after ordering number (please refer to PK1-2). Example: 5/150-19-DXE, 200-35-BXE.
- 6 The DPI is sensitive in the range of 0-5 psi differential.

Ordering Information				
For assistance, call toll-free at 1-800-343-4048 8AM to 5PM Eastern Time				
Model	2206	2208	2312	A15/80
Differential Pressure Indicator (6)	Included	Included	Included	Included
Replacement Filter Cartridges				
No. Required	1	1	1	1
Box of 5 (5)	5/150-19-□	5/150-19-□	5/200-35-□	5/200-80-□
Box of 10 (5)	150-19-□	150-19-□	200-35-□	200-80-□
CI Cartridge (Box of 1)	CI 150-19-000	CI 150-19-000	CI 200-35-000	CI 200-80-000

K-Series and H-Series Multiple Cartridge Filter Assemblies

These filter assemblies provide high efficiency filtration of compressed air and other compressed gases at very high flow rates. With inlet and outlet ports accommodating 3" to 10" pipe sizes, standard K-series and H-series housings are available in carbon steel or Type 316 stainless steel construction up to a maximum capacity of 28,000 SCFM at 100 psig. The standard carbon steel units, which are generally in stock (through 6" line size), have pressure ratings from 200 to 325 psig. Special high pressure units can be provided for pressure ratings to 665 psig.

All K-series and H-series housings are ASME Code Stamped for the rated maximum operating pressure (except Model AKN-0280). All vessels have built-in legs for floor mounting. With the exception of Model AKN-0280, all vessels have in-line Flanged ports.

In all K-series models, the filter cartridges are sealed by tightening the threaded retainer cap onto the rigid tie rod. Since the filter cartridges are self-gasketing, the only resilient seal in the system is the o-ring in the head of the vessel.

Each K-series Assembly is equipped with a stainless steel automatic float drain (P/N 20-211), differential pressure indicator (P/N 41-071), and a set of filter cartridges (except where noted).



Model AKN-0280



Model AKC-1480

Principal Specifications

Model (3)	AKN-0280 (7)	AKC-0280	AKC-0480	AKC-0880	AKC-1480	AKC-2280
Port Size	3" NPT	3" FLG	4" FLG	6" FLG	8" FLG	10" FLG
Materials of Construction						
Vessel	Carbon Steel	Carbon Steel	Carbon Steel	Carbon Steel	Carbon Steel	Carbon Steel
Filter Cartridge Holders	303 St. Steel	303 St. Steel	303 St. Steel	303 St. Steel	303 St. Steel	303 St. Steel
Seals	Buna-N	Buna-N	Buna-N	Buna-N	Buna-N	Buna-N
Maximum Temperature (1)	250°F (121°C)	230°F (110°C)	230°F (110°C)	250°F (121°C)	250°F (121°C)	250°F (121°C)
Maximum Pressure (2)	325 psig	250 psig	250 psig	200 psig	200 psig	200 psig
Minimum Pressure (4)	10 psig	10 psig	10 psig	10 psig	10 psig	10 psig
Shipping Weight	132 lbs. (60 kg)	140 lbs. (64 kg)	210 lbs. (64 kg)	360 lbs. (163 kg)	590 lbs. (268 kg)	880 lbs. (400 kg)
Dimensions	6.6"W X 36"H (17cm X 92cm)	16"W X 36"H (41cm X 91cm)	21"W X 36"H (53cm X 91cm)	25"W X 38"H (64cm X 97cm)	34"W X 54"L (86cm X 137cm)	36"W X 56"H (91cm X 142cm)
Flange Center Line to Floor Dimension	7.6" (19 cm)	7.75" (20cm)	6.25" (11cm)	7.5" (19cm)	16.25" (41cm)	17.25" (44cm)
Flange to Flange Dimension	13"	15.62"	20.63"	24.75"	34"	36"

Footnotes on page 11.

Principal Specifications - High Pressure Group

Model (5)	AKH-0280	AKH-0480	AKH-0880	AKH-1480	AKH-2280
Port Size	3" FLG	4" FLG	6" FLG	8" FLG	10" FLG
Materials of Construction					
Vessel	Carbon Steel	Carbon Steel	Carbon Steel	Carbon Steel	Carbon Steel
Filter Cartridge Holders	303 St. Steel	303 St. Steel	303 St. Steel	303 St. Steel	303 St. Steel
Seals	Buna-N	Buna-N	Buna-N	Buna-N	Buna-N
Maximum Temperature (1)	250°F (121°C)	250°F (14°C)	250°F (121°C)	250°F (121°C)	250°F (121°C)
Maximum Pressure (2)	665 psig	665 psig	665 psig	665 psig	665 psig
Minimum Pressure (4)	10 psig	10 psig	10 psig	10 psig	10 psig
Shipping Weight	150 lbs. (68 kg)	270 lbs. (123 kg)	560 lbs. (254 kg)	1120 lbs. (508 kg)	1430 lbs. (649 kg)
Dimensions	16"W X 41"H (41cm X 104cm)	21"W X 40"H (53cm X 102cm)	25"W X 43"H (64cm X 109cm)	34"W X 54"H (86cm X 137cm)	36"W X 57"H (91cm X 145cm)
Flange Center Line to Floor Dimension	7.75" (20cm)	6.25" (16cm)	8.5" (22cm)	16.25" (41cm)	17.25" (44cm)
Flange to Flange Dimension	15.63" (40cm)	20.63" (52cm)	24.75" (63cm)	34" (86cm)	36" (91cm)

Ordering Information (3)

For assistance, call toll-free at 1-800-343-4048 8AM to 5PM Eastern Time

Model	AKN-0280-□	AKC-0280-□	AKC-0480-□	AKC-0880-□	AKC-1480-□	AKC-2280-□
Replacement Filter Cartridges						
No. Required	2	2	4	8	14	22
Box of 5 (6)	5/200-80-□	5/200-80-□	5/200-80-□	5/200-80-□	5/200-80-□	5/200-80-□
Box of 10 (6)	200-80-□	200-80-□	200-80-□	200-80-□	200-80-□	200-80-□
CI Cartridge (Box of 1)	CI-200-80-000	CI-200-80-000	CI-200-80-000	CI-200-80-000	CI-200-80-000	CI-200-80-000

Ordering Information - High Pressure Group (4)

For assistance, call toll-free at 1-800-343-4048 8AM to 5PM Eastern Time

Model (5)	AKH-0280-□	AKH-0480-□	AKH-0880-□	AKH-1480-□	AKH-2280-□
Replacement Filter Cartridges					
No. Required	2	4	8	14	22
Box of 5 (6)	5/200-80-□	5/200-80-□	5/200-80-□	5/200-80-□	5/200-80-□
Box of 10 (6)	200-80-□	200-80-□	200-80-□	200-80-□	200-80-□
CI Cartridge (Box of 1)	CI-200-80-000	CI-200-80-000	CI-200-80-000	CI-200-80-000	CI-200-80-000

Notes:

1 Maximum operating temperature of carbon steel vessel is 650°F (343°C). Minimum operating (process and ambient pressure) temperature is -20°F (29°C). Max. Temps. for Seal material: 250°F (Buna), 400°F (Viton), 450°F (Silicone). Seal material may not be the limiting factor. Maximum temperature for assemblies with DPI is 130°F (54°C)

2 Vessel is ASME Section VIII, Div. 1 code stamped for rated pressure. All AKC series housings have CRN registration numbers assigned in all Canadian provinces.

3 K-series Filter Assemblies are shipped complete with Automatic Drain (P/N 20-211), Differential Pressure Indicator (P/N 41-071), and one set of filter cartridges.

4 Maximum operating pressure for 41-071 Differential Pressure Indicator is 250 psig. The DPI is sensitive in the range of 0-7 psi differential. The Maximum operating pressure for 20-211 Auto Drain is 400 psig. Minimum operating pressure is 10 psig.

5 Differential Pressure Indicator and Automatic Drain are not included with AKH Assemblies, or with assemblies containing Type CI Cartridges.

6 To order filter cartridges, indicate grade of filter cartridge by placing appropriate letter cartridge designation after the last digit. Example: 200-80-DXE.

7 AKN-0280 is not ASME code stamped.

Models 9955-05-DX, 9955-11-DX, 9955-12-DX, 18/18-DX

Balston Filter/Silencers for air exhausts offer the combination of unusually effective sound attenuation and filtration of all visible oil mist from the exhaust air. The Filter/Silencers are available in 1/8", 1/4", 1/2", and 3/4" port sizes. They contain a Grade DX Microfiber Filter Cartridge sealed into a molded nylon or steel holder.

Balston Filter/Silencers are remarkably efficient sound mufflers, far more efficient than the felts, pleated paper, sintered plastic, and sintered metal products commonly used in other exhaust silencers. A sound attenuation efficiency test comparing a 9955-12-DX, 1/2" Filter/Silencer with a sintered polyethylene silencer is described below.

This silencing efficiency test simulates the action of an air cylinder discharging rapidly to atmosphere. A length of 1/2" line between two ball valves is pressurized with air to a controlled pressure. The upstream valve is closed and then the downstream valve is opened rapidly to discharge the fixed volume of air under pressure to atmosphere. Noise levels were measured at a 3 foot distance with no silencer on the end of the line, with the Balston Filter Silencer, and with competitive silencers.



Model 9955-05-DX



Model 9955-11-DX



Model 9955-12-DX



Model 18/18-DX

Noise Level (dBA)	Upstream Pressure (psig)				
	100	80	60	40	20
Without Silencer	102	102	101	99	95
With Balston Silencer	70	70	69	67	65
With Sintered Polyethylene Silencer	88	88	87	87	81

A similar test of the Model 18/18 on a 3/4" air line gave the following results:

Sound Level 3 ft. from 3/4" Air Line Discharging Air At 100 PSIG Atmosphere	
Without Silencer	With Model 18/18-DX
113 dBA	94 dBA



Principal Specifications				
Model	9955-05-DX	9955-11-DX	9955-12-DX	18/18-DX
Inlet Port	1/8" NPT (Male)	1/4" NPT (Male)	1/2" NPT (Male)	3/4" NPT (Female)
Drain Port	1/4" OD Tubing	1/4" OD Tubing	1/4" OD Tubing	1/8" NPT (Female)
Materials of Construction	Borosilicate glass microfibers with fluorocarbon resin binder			
Filter Cartridge	Borosilicate glass microfibers with fluorocarbon resin binder			
Holder	Nylon	Nylon	Nylon	Steel
Internals	---	---	---	Steel
Maximum Internal Pressure at 110°F (43°F) (1)	100 psig	100 psig	100 psig	100 psig
Maximum Temp. at 0 psig Internal Pressure	260°F (127°C)	260°F (127°C)	260°F (127°C)	300°F (149°C)
Shipping Weight	0.5 lb (0.2 kg)	0.5 lb (0.2 kg)	0.5 lb (0.2 kg)	1 lb (0.5 kg)
Dimensions	1.4" dia. X 2.0"h (4cm X 5cm)	1.4" dia. X 3.0"h (4cm X 8cm)	2.0" dia. X 3.7"h (5cm X 9cm)	3.5" dia. X 5.4"h (9cm X 14cm)

Notes:

1 With the outlet open to atmosphere. Otherwise, maximum internal pressure is 15 psig.

Ordering Information	
For assistance, call toll-free at 1-800-343-4048 8AM to 5PM Eastern Time	
Model	Description
9955-05-DX, 9955-11-DX, 9955-12-DX	Standard Pack 10 Filter Silencers per box, individually wrapped
18/18-DX	One Model 18/18-DX per box.

Flow Rates			
Filter Housing Type	Flow Rate from Pressured Line through Filter to Atmosphere (cu. ft. per sec.)		
	100 psig Line Pressure	60 psig Line Pressure	20 psig Line Pressure
9955-05-DX	3	1.2	0.2
9955-11-DX	10	4	0.7
9955-12-DX	35	14	2.2
18/18-DX	105	42	6.6

Filter-Regulator Combinations

Balston Filter-Regulators combine a high efficiency coalescing filter with a high quality pressure regulator. Air flows through the filter, then to the pressure regulator. The filter is a Balston coalescing compressed air filter (Grade BX) and will completely remove oil, water, and dirt from compressed air and other compressed gases. Flow direction through the element is inside-to-outside for optimum oil and water removal. An automatic drain is installed on the 3/8", 1/2", and 3/4" models offering maintenance-free operation. Pressure gauges are standard and are available in up to 4 different ranges (see ordering information).



AFR-940, AFR-940A



12E Series

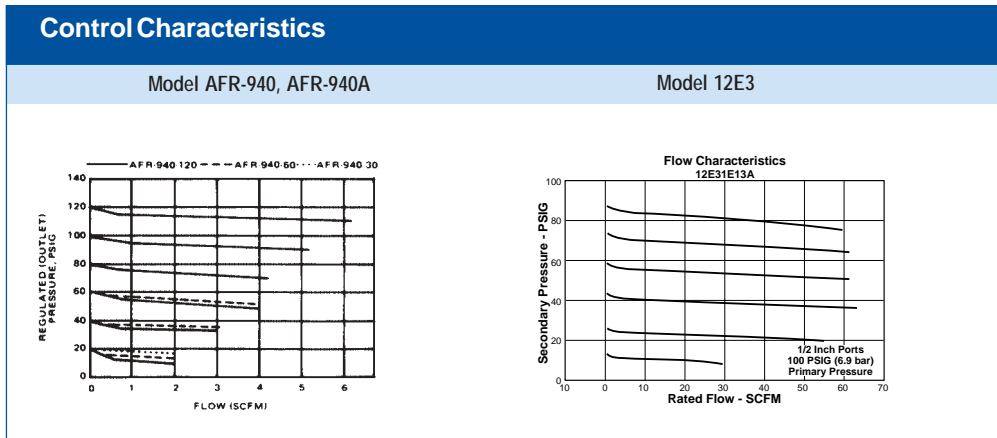

Principal Specifications					
Model	AFR-940	AFR-940A	12E27	12E37	12E47
Port Size	1/4" NPT	1/4" NPT	3/8" NPT	1/2" NPT	3/4" NPT
Gauge Ports	1/8" NPT	1/8" NPT	1/4" NPT	1/4" NPT	1/4" NPT
Materials of Construction					
Head	Anod. Alum.	Anod. Alum.	Zinc	Zinc	Zinc
Bowl	Polycarb.	Anod. Alum.	Zinc	Zinc	Zinc
Bonnet	Polycarb.	Polycarb.	Plastic	Plastic	Plastic
Internals	Brass/Buna	Brass/Buna	Zinc/Nitrile	Zinc/Nitrile	Zinc/Nitrile
Maximum Temperature	220°F (104°C)	220°F (104°C)	125°F (52°C)	125°F (52°C)	125°F (52°C)
Maximum Pressure (2)	150 psig	250 psig	250 psig	250 psig	250 psig
Minimum Pressure	---	---	15 psig (1)	15 psig (1)	15 psig (1)
Shipping Weight	0.5 lbs. (0.2 kg)	0.5 lbs. (0.2 kg)	2.5 lbs. (1.1 kg)	2.5 lbs. (1.1 kg)	2.5 lbs. (1.1 kg)
Dimensions	1.2"W X 6"L (3cm X 15cm)	1.2"W X 6"L (3cm X 15cm)	3.25"W X 13"L (8 cm X 33cm)	3.25"W X 13"L (8 cm X 33cm)	3.25"W X 13"L (8cm X 33cm)

Ordering Information					
For assistance, call toll-free at 1-800-343-4048 8AM to 5PM Eastern Time					
Model	AFR-940	AFR-940A	12E27	12E37	12E47
Control Gauge Pressure Range					
0-30 psig	AFR-940-30	AFR-940A-30	see ordering matrix below	—————▶	—————▶
5-60 psig	AFR-940-60	AFR-940A-60	see ordering matrix below	—————▶	—————▶
10-130 psig	AFR-940-130	AFR-940A-130	see ordering matrix below	—————▶	—————▶
Auto. Drain (1)	N/A	N/A	Included	Included	Included
Replacement Filter Cartridges					
Number Required	1	1	1	1	1
Box of 5	5/050-05-BXE	5/050-05-BXE	5/130-14-BXE	5/130-14-BXE	5/130-14-BXE
Box or 10	050-05-BXE	050-05-BXE	130-14-BXE	130-14-BXE	130-14-BXE
Mounting Bracket	11536	11536	PS807P	PS807P	PS807P

Notes:

1 Minimum operating pressure for automatic drain is 15 psig.

2 Maximum pressure ratings are for temperatures to 130°F (54°C). Please consult the factory for maximum pressure ratings at elevated temperatures.

How to Order

To order product with desired port size and Regulating Pressure Range, select the indicator digits from the matrix (at right). This will complete the entire model number which is needed to place an order.

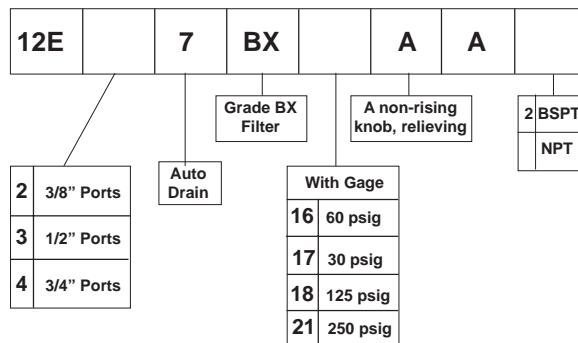

Model 17L Series

Many pneumatic system components and most tools require oil lubrication for proper operation and long service life. This lubricant is typically carried by the air stream. Too little oil can cause excessive wear and premature failure. Too much oil is wasteful and can become a contaminant. Use of the proper lubricator can greatly extend the life of expensive downstream pneumatic equipment.

The 17L Series Micro-Mist Lubricators offer proportional oil delivery over a wide range of air flows. The precision needle valve assures repeatable oil delivery and provides simple adjustment of delivery rate. They are designed to generate oil droplets of 5 microns or smaller downstream to lubricate systems having complex piping arrangements. The 17L series are ideal for low and high flow applications with changing air flow.



17L Series

How to Select the Correct Lubricator

Once the required flow is determined for a pneumatic application, the lubricator can be selected by using the flow chart. To read the lubricator flow chart, first determine the inlet pressure that will be used. Find the appropriate pressure curve on the graph. Each graph will contain three pressure curves. If the required inlet pressure is not on the graph, interpolate a similar curve for the required pressure. Next, determine the accept-

able pressure drop across the lubricator and locate it on the vertical axis. Find the intersection point of the acceptable pressure drop and the inlet pressure curve. At this point, follow a vertical path downward to view the flow in SCFM. If the flow is too low, select a larger port size or body size to give the required flow. If the flow is higher than necessary, select a smaller port size or body size to give the required flow.

Model 17L22B

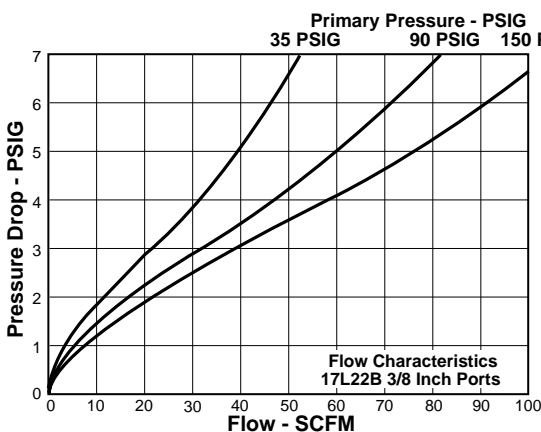

Model 17L32B and 17L42B

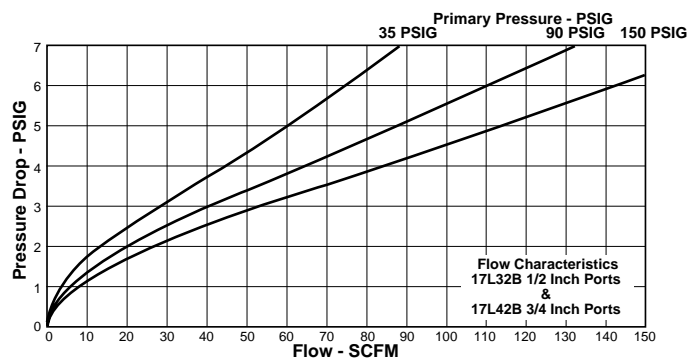

Principal Specifications			
Model	17L22BE	17L32BE	17L42BE
Port Size	3/8" NPT	1/2" NPT	3/4" NPT
Gauge Ports	1/4" NPT	1/4" NPT	1/4" NPT
Materials of Construction			
Head	Zinc	Zinc	Zinc
Bowl	Polycarbonate	Polycarbonate	Polycarbonate
Bowl Guard	Steel	Steel	Steel
Collar	Plastic	Plastic	Plastic
Seal	Nitrile	Nitrile	Nitrile
Sight Dome	Polycarbonate	Polycarbonate	Polycarbonate
Sight Gage	Polyamide	Polyamide	Polyamide
Maximum Temperature	125°F (52°C)	125°F (52°C)	125°F (52°C)
Maximum Pressure	150 psig	150 psig	150 psig
Minimum Pressure	15 psig	15 psig	15 psig
Shipping Weight	1.9 lbs. (0.9 kg)	1.9 lbs. (0.9 kg)	1.9 lbs. (0.9 kg)
Dimensions	3.25"W X 9.27"L (85mm X 235mm)	3.25"W X 9.27"L (85mm X 235mm)	3.25"W X 9.27"L (85mm X 235mm)

Ordering Information			
For assistance, call toll-free at 1-800-343-4048 8AM to 5PM Eastern Time			
Model	17L22BE (3/8"NPT)	17L32BE (1/2"NPT)	17L42BE (3/4"NPT)
Service Kit	PS748P	PS748P	PS748P

High Capacity Electric Solenoid Drain

The Balston Automatic Drain Assembly, P/N 20-440 automatically removes water from Balston filter housings. The autodrain consists of a solenoid valve and an automatic timer that can be adjusted to the desired cycle time and is powered by 120/240 VAC, 50/60 Hz. To drain receiving tanks, use any commercially available Y-strainer (ex. Keystone 911 Series or Watts Model 7771) to protect the 20-440.



20-440

High Capacity Non-Electrical Float Drain

In the 20-211 design, a sealed stainless steel float operates a needle valve by means of a lever. All internal parts are stainless steel. The 20-211 drain is a rugged design for high volumes of liquid.



20-211

Normal Capacity Non-Electrical Float Drain

In the 20-402 design, a float rises to operate a pilot-controlled valve when the liquid level in the body of the drain reaches a predetermined level. The float is reset by the force of line pressure as soon as the liquid is drained.



20-402

Principal Specifications and Ordering Information

Model	20-211	20-440	20-402
Port Size	1/2" NPT	1/4" NPT	1/4" NPT
Maximum Pressure	400 psig	300 psig	200 psig
Minimum Pressure	10 psig	20 psig	15 psig
Maximum Temperature	500°F (260°C)	122°F (50°C)	130°F (54°C)
Shipping Weight	2 lbs. (0.9 kg)	2 lbs. (0.9 kg)	2 lbs. (0.9 kg)
Dimensions	2.5"W X 7.3"L (6cm X 19cm)	3"W X 4"L (7cm X 10cm)	3"W X 4L (7cm X 10cm)





Model 20-600

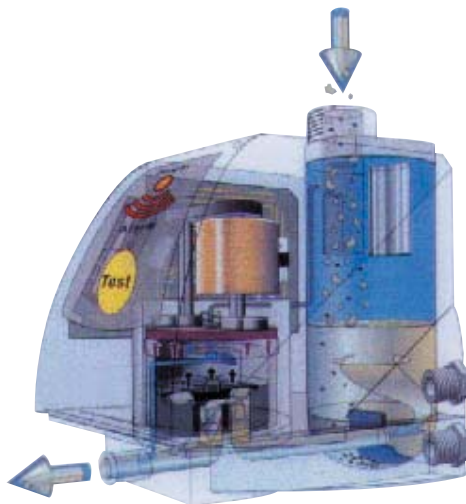

Conserves compressed air energy, zero compressed air is expelled, only oil/water condensate

Condensate can be piped to the top or bottom of drain, simplifying difficult installations

Automatically adjusts to all common powers from 24V to 230V

Test button enables manual discharge

Internal electronics continuously monitor operation, and alarm light on front panel indicates faults

Zero Air Loss Drain

The Parker Balston Zero Air Loss Drain is suitable for use on all filters and dryers. As condensate collects in the internal sump, a diaphragm is held closed by the system pressure. When the liquid level sensor detects an accumulation of condensate, an electromagnet is activated, relieving the system pressure above the diaphragm. As the condensate level decreases, system pressure is reintroduced above the diaphragm, closing off the flow of condensate before compressed air can escape.

Ideal for filters with flow rates to 3600 SCFM, and for dryers rated up to 720 SCFM.

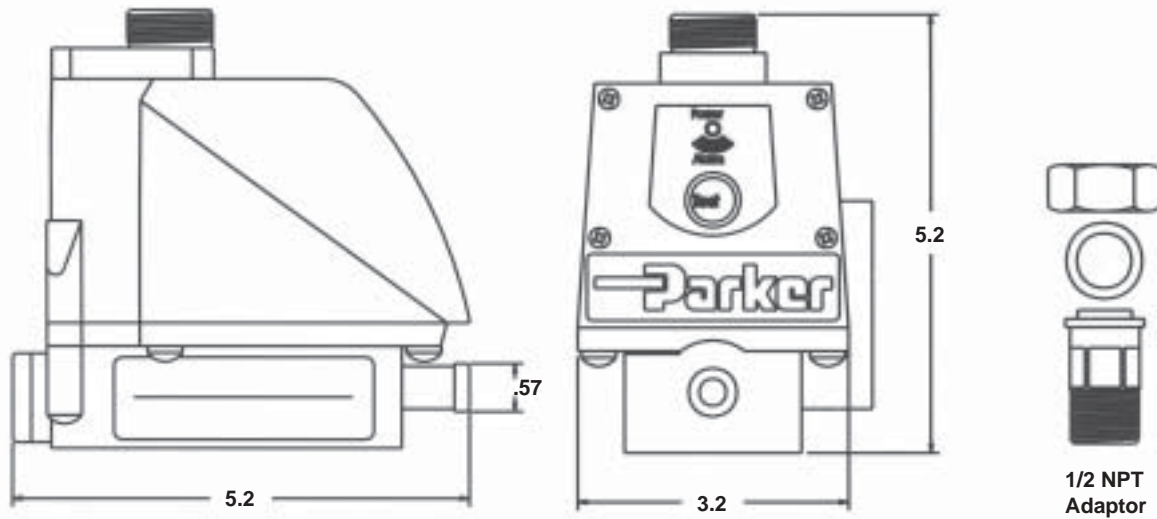

1/2 NPT
Adaptor

Principal Specifications

Model	20-600
Maximum Compressor Performance	360 SCFM (612 NM ³ /H)
Maximum Refrigerated Dryer Performance	720 SCFM (1224 NM ³ /H)
Maximum Filter Capacity	3600 SCFM (6120 NM ³ /H)
Short Term Condensate Quantity	8 gal/h (100 PSI)
Pressure Range	12-250 PSI (0.8-17 bar)
Power Supply	24-230 V _{DC} , self regulating 80-230V _{AC} , self regulating
Power Consumption	5VA
Potential-Free Alert Contact	Max. 350 V AC/DC, Max. 0,1A (electric relays)
Temperature Range	35°F to 140°F (2°C to 60°C)
Protection	NEMA 4x or IP 65
Weight (empty)	2 lbs. (1 kg.)
Materials of Construction	
Wetted Plastic Parts	High impact glass filled engineered plastic
Body	Aluminum Coated
Seals	Viton

Ordering Information

For assistance, call toll-free at 1-800-343-4048 8AM to 5PM Eastern Time	
Model 20-600	Zero Air Loss Drain
301364	Repair Kit

Notes:

1 Installation is quick and simple. A 1/2" NPT pipe adaptor (supplied) is threaded into a filter housing drain port. A drip leg, or other pipe connection and the 20-600 can then be fitted into the system with the simple twist of a threaded collar.



Balston Differential Pressure Indicator

The Balston Differential Pressure Indicator (DPI) is used to monitor the pressure drop across the filters or other components in a compressed air system. The DPI is sensitive in the range of 0 to 5 psi differential.

Principal Specifications & Ordering Information		
Model	41-070	41-082
Differential Pressure Indicator	41-070	41-082
Indicator and Installation Kit (1)	41-071	N/A
Port Size	1/8" NPT	3/8"-24
Maximum Pressure	250 psig	250 psig
Maximum Temperature	130°F (54°C)	130°F (54°C)
Dimensions	1.7"W X 1.8"H (4cm X 5cm)	2.9"W X 2.25"H (7cm X 6cm)

Note

1 Installation kit includes fittings and tubing necessary for line-mounting the 41-070 DPI



41-070



41-070 Mounted on Filter Assembly



41-082



41-082 Mounted on Filter Assembly

Models 9922-05, 9933-05, 4433-05 and 9900-05

The 99XX-05 Models are the smallest Disposable Filter Units with 11.7 ml internal volume. These models are used in low flow gas or liquid sampling applications, such as liquids to specific-ion analyzers or gases to personal samplers. The Model 4433-05 has 1/4" and 3/8" barb connections molded into the inlet/outlet ports. The 9900-05 is available with a color indicator that turns red when saturated with oil.

Models 9922-11 and 9933-11

Models 9922-11 and 9933-11 are used for applications similar to the smaller DFUs (Models 9922-05 and 9933-05) which require greater solids holding capacity and can tolerate the increased retention time.

Model 8833-11

These Disposable Filter Units are used as continuous coalescing filters with a third port serving as the drain, slip-stream, or by-pass port.

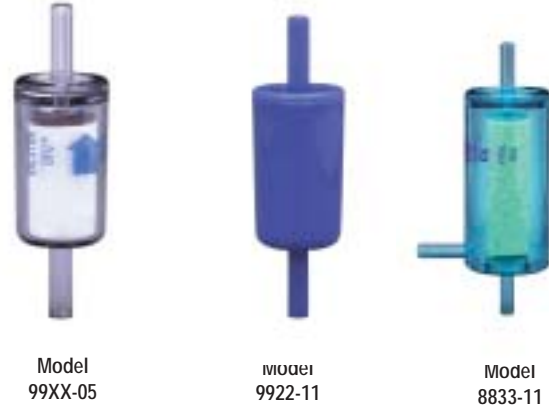

Retention Efficiency	
Model	Efficiency for 0.01 Micron Particles and Droplets
DX	93%
BX, BK	99.99%

Flow Rates											
Air Flow at 2 psi drop, standard cu. ft. per min. (SCFM) at indicated line pressure											
Filter Housing Type	Volume of Housing (CU. FT.)	Filter Tube Grade	Flow Rate (CFM) At 10" Water Press. Drop., 0 PSIG	Flow Rate (CFM) At							
				2 psig	20 psig	40 psig	60 psig	80 psig	100 psig	125 psig	
9900-05	0.0004	DQ	0.2	1.2	2.5	3.9	5.4	6.8	8.3	10.1	
9922-05		BQ/BK	0.1	0.8	1.6	2.6	3.5	4.5	5.4	6.6	
9933-05			4433-05								
8822-11	0.0007	DX	0.4	1.8	3.6	6	8	10	12	14.6	
8833-11		BX	0.2	0.9	1.8	3	4	5	6	7.3	
9922-11											

Installation Information

Compression fittings for 1/4" O.D. tubing may be obtained from the following manufacturers: Hoke, Inc. (Gyrolock); Crawford Fitting Co. (Swagelok); Parker-Hannifin Corp. (CPI); Legris, Inc. (push-on fittings); Jaco Mfg. Co. (plastic fittings).

The following brass fittings seal by O-ring compression and may be completely recovered and reused when changing filters. They may be purchased from Parker Hannifin Corp.

- Connector 1/4" tubing to 1/4" NPT, female - P/N 11970
- Connector 1/4" tubing to 1/4" tubing - P/N 11971
- Elbow on 1/4" tubing to 1/8" NPT female (for manual drain on Type 8833-11) - P/N 11972

For connections to low pressure plastic tubing

Tubing with 1/4" ID may be slipped over the DFU end fittings and held with tubing clamps. Parker Hannifin Corp. supplies plastic barbs to connect the DFU to smaller diameter plastic tubing. The connection is suitable for pressures to 50 psig.

- DFU to 1/16" ID tubing P/N 14000 (bag of 20 barbs)
- DFU to 1/8" ID tubing P/N 14001 (bag of 20 barbs)

Parker Hannifin Corp. also offers a manual drain valve for removal of coalesced liquids from the Type 8833-11-DX

- Drain Valve 1/8" NPT (male) x 1/8" ID tubing (requires elbow part 11972) P/N 20125

Principal Specifications						
Model	9922-05	9900-05, 9933-05	4433-05	9922-11	9933-11	8833-11
Inlet and Outlet Ports	1/4" Tubing	1/4" Tubing	1st Tier/Barb 1/4" Tube 2nd Tier/Barb 3/8" Tube	1/4" Tubing	1/4" Tubing	1/4" Tubing
Drain	None	None	None	None	None	1/4" Tubing
Material of Construction	PVDF	Nylon	Nylon	PVDF	Nylon	Nylon
Filter Cartridge Length	1.25" (3.2 cm)	1.25" (3.2 cm)	1.25" (3.2 cm)	2.25" (5.7 cm)	2.25" (5.7 cm)	2 1/4"
Maximum Temperature (1)	275°F (135°C)	230°F (110°C)	230°F (110°C)	275°F (135°C)	230°F (110°C)	230°F (110°C)
Maximum Pressure (2)	125 psig	125 psig	125 psig	125 psig (2)	125 psig (2)	125 psig (2)
Dimensions	1.0"D X 3.25"L (2.5 cm X 6 cm)	1.0"D X 3.25"L (2.5 cm X 6 cm)	1.0"D X 3.43"L (2.5 cm X 8.72 cm)	1.4"D X 4.6"L (9.1 cm X 12 cm)	1.4"D X 4.6"L (9.1 cm X 12 cm)	1.4"D X 4.6"L (9.1 cm X 12 cm)

Ordering Information							
For assistance, call toll-free at 1-800-343-4048 8AM to 5PM Eastern Time							
Model	9922-05	9900-05	4433-05	9933-05	9922-11	9933-11	8833-11
Filter Cartridges	9922-05-□ Box of 10	9900-05-□	4433-05-□	9933-05-□	9922-11-□	9933-11-q	8833-11-q
Available in types Q and X (3)							

Notes:

1 At 0 psig

2 At 110°F (43°C)

3 To designate the grade of filter tube in the DFU, insert Grade letters after DFU designation. For example, to obtain a grade BQ filter tube in a DFU 9922-05, order: 9922-05-BQ. Please note the following limitations:

DFU	Supplied With These Grades
4433-05, 9900-05, 9922-05, 9933-05	DQ, BQ, AQ (BK) (4)
9922-11, 9933-11	DX, BX, AQ
8822-11, 8833-11	DX, BX

4 The BK Grade filter has a color indicating feature, which turns the cartridge red when saturated with oil.

Application Notes

Balston Sample Filters



Remove liquids and solids from gas samples

Remove solids and gas bubbles from liquid samples

Coalesce and separate two liquid phases

Filter solids and liquids from gases with 99.999% efficiency at 0.01 μm

Temperature resistance to 900°F (482°C)

Low pressure drop

Long life between filter element changes

Balston Sample Filters Protect Sensitive Analyzers

Balston Gas and Liquid Sample Analyzer Filters protect analyzers from sample impurities by removing solids and liquids from gases with 99.999% efficiency at 0.01 micron. Balston Sample Filters offer liquid filtration to 1 micron or lower. Composed of borosilicate glass microfibers with a resin binder, Balston sample filters are inert to most any gas or liquid.

To satisfy the extremely wide range of requirements for analyzer sample filters, Parker Hannifin Corporation supplies a complete line of filter housings in stainless steel, polypropylene, and other corrosion resistant materials, as well as a choice of high efficiency filter elements which are inert to most all liquids and gases.

NEW

from Parker Balston!

Energy Saving Filter Cartridges!

New and improved with the same filter performance you have come to expect from Balston cartridges, the new XE-Cartridges will reduce your annual operating costs!

What is creating the operating cost?

For every 2 psi of differential pressure in a compressed air system, the drive energy on the compressor is increased by 1%.

By minimizing differential pressure drop through compressed air filters, less drive energy on the compressor is realized and thus lower energy costs.

What is the savings solution?

The new XE-Cartridges from Parker Balston exhibit a 2+ psi pressure drop improvement over the current X cartridge. This produces a cost savings of \$27.00 to \$240.00 per year per installed filter cartridge depending on the number of work shifts.*

How do I order them?

For your next order of filter cartridge replacements be sure to order the NEW XE-Cartridges! Just simply add an "E" for energy savings to the end of the part number! See example below.

Current Part #	New Part #
100-18-DX	100-18-DXE

Now is the time to outfit your entire facility with the NEW Parker Balston XE-Cartridge!

If you have any questions please feel free to call us at 800-343-4048 and ask for Technical Services Department.

*based on \$0.07 Kwh as a national average electrical cost. Savings are more significant in higher cost regions!



Table 1 Filter Cartridge Description

LP Cartridges:	Designed to filter liquids with high solids contents. Have an integral prefilter and an external support structure (flow direction is inside-to-outside).
X-Type Cartridges:	Used for solids and relatively large amounts of suspended liquids in gases. Provide excellent chemical resistance, temperature resistance to 300°F (150°C), and good mechanical handling properties. These cartridges have thick walls for improved coalescing efficiency. Should be used whenever permitted by housing internal volume. Fluorocarbon Resin Binder.
Q-Type Cartridges:	Used for solids and trace amounts of liquids in gases. Similar to X-Type cartridges in chemical and temperature resistance. Fluorocarbon Resin Binder.
H-Type Cartridges:	Recommended for oxygen service or when X-Type or Q-Type are unsuitable. H-Type cartridges have temperature resistance to 1000°F (538°C) in dry gas, 100°F (38°C) in liquid. Quartz construction.
Sintered Stainless Steel Cartridges:	Designed for applications having heavy loading of solid contaminants. These cartridges are also suitable for removing heavy, viscous liquids from gases and as prefilters to high efficiency final filters. Constructed of 316 stainless steel with molded viton end seals.
CI Cartridges:	Used to remove trace quantities of oil vapor. Activated carbon sandwiched between two layers of microfiber filter media absorbs oil vapor. Must be prefiltered with Grade DX and Grade BX.

Filter Cartridge Description

Parker Hannifin supplies filter cartridges in three different designs: LP Cartridges, Sintered Stainless Steel Cartridges, and Microfibre Filter Cartridges (X, H, or Q-type). See Table 1 for descriptions:

How To Select The Filter Cartridge

- 1 When selecting a cartridge, do not overspecify. Select the coarsest grade which will adequately protect the instrument. Coarser grade filters provide lower pressure drop and longer life than finer grades.
- 2 When selecting X, Q, or H type cartridges, a D or B positioned before the cartridge type will determine the retention efficiency (see chart to the left). For LP and Sintered Stainless Steel Cartridges, the numerical Grade value indicates retention efficiency (see Table 2).
- 3 Refer to the chemical compatibility chart on page 29 to confirm compatibility of the filter cartridge material with the sample composition.

Table 2 Retention Efficiency of Filter Cartridges for Gas and Liquid Sample Filtration

Gas Filtration at 0.01 µm	
Microfibre Filter Cartridges	
Grades DXE, DQ, DH	93%
Grades BXE, BQ, BH	99.99%
Grade AQ	99.9999+%
Grade AAQ	99.9999+%
Liquid and Gas Filtration at Indicated Micron Size	
Sintered SS Cartridges	
Grade 5M	5 µm Nominal
Grade 10M	10 µm Nominal
Grade 20M	20 µm Nominal
Grade 40M	40 µm Nominal
Grade 70M	70 µm Nominal
Grade 00M	100 µm Nominal
Liquid Filtration	
Microfibre Filter Cartridges (98% retention)	
Grades DXE, DQ, DH	25 µm
Grades BXE, BQ, BH	2 µm
Grade AQ	0.9 µm
Grade AAQ	0.3 µm
LP Cartridges (80% retention)	
Grade 10	75 µm
Grade 20	25 µm
Grade 30	10 µm
Grade 50	1 µm

How To Select The Filter Housing

- 1 Select a filter housing in the material appropriate for your application. Please refer to the Application Index on page 29, and the appropriate data sheet.
- 2 Select a filter housing with a port size equal to the line size where the filter is to be located. If the line size at the filter has not yet been selected, determine the gas flow rate and pressure at the point where the filter will be located, and refer to the appropriate flow chart on pages 30 and 31 of this bulletin. Flow rates for liquids are located on page 30 and flow rates for air and gas sample filters are located on pages 31 and 32.



Vapor Adsorption Cartridges

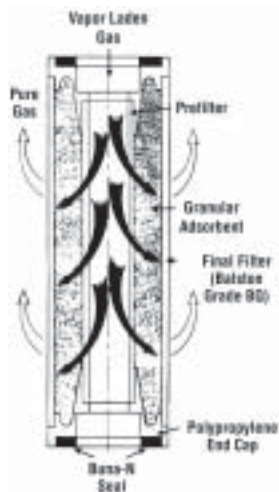

Notes:

1 In DAU 9933-05-107 and DAU 9933-11-107, color indicator turns violet when adsorbent is spent.

2 Maximum operating temperature is 180°F.

Type CI Vapor Adsorption Cartridges contain a bed of adsorbent granules in the annular space between two Microfibre Filter Tubes, with permanently bonded end caps. Utilizing a wide choice of adsorbents, the Type CI cartridges selectively remove vapors from air and other gases. Flow direction is inside-to-outside through the cartridge, and the outer Microfibre Filter cartridge serves as an integral final filter to prevent carryover of adsorbent particles.

For low flow applications, Disposable Adsorption Units (DAU) provide a means of utilizing the same choice of adsorbents used in the Type CI cartridges in a completely disposable package (please refer to page 34).

Because the absorbed vapor remains trapped in the solid bed, the Type CI cartridge has a fixed upper limit of total weight of vapor which can be captured. It is usually not feasible to regenerate the cartridge when it has reached its adsorption limit. Type CI cartridges should be used only when small quantities of vapor are to be removed.

Adsorbents used in Type CI Cartridges

Adsorbent	Grade No.	Use For
Carbon	000	Compressor oil vapors, C ₅ and heavier hydrocarbons, aromatics, oxygenated hydrocarbons, chlorinated organics, freons, carbon disulfide.
Molecular Sieve 13X	103	Most C ₄ and lighter hydrocarbons, ethylene, propylene, acetylene, ethylene Type oxide, ammonia, mercaptans, sulfur hexafluoride, triethylamine, and smaller amines.
Mixed Sodium and Calcium Hydroxides	107	all acidic gasses, including sulfur trioxide, sulfur dioxide, nitrogen dioxide, Carbon dioxide, hydrogen sulfide, hydrogen chloride, phosphorus trichloride, boron trifluoride.

Considerations in Using Adsorbent Cartridges

The following factors should be considered when selecting a vapor adsorbent cartridge:

- 1 Solid adsorbents are effective only for vapors. Since liquids will damage or inactivate most solid adsorbents, the Type CI cartridge or DAU must be preceded by an efficient coalescing filter. Recommendations for prefilters are given on page 27.
- 2 In contrast with Microfibre Filters, which operate at their initial efficiency throughout their life, adsorbent cartridges have a limited holding capacity. When the adsorption capacity is reached, no further adsorption occurs. The limiting capacity, or "break-through" point, is not sharply defined, and the exit vapor concentration will increase rapidly as saturation is approached. To avoid unwanted vapor contaminants downstream, it is necessary to change the adsorbent cartridge will before it has reached its ultimate adsorption capacity.
- 3 Adsorption is reversible, if operating conditions change, a vapor may desorb rather than adsorb. For example, if a temporary surge in vapor impurity concentration causes a relatively high concentration to be absorbed on the solid, a subsequent decrease in inlet vapor composition will result in desorption of vapor from the solid to the gas stream.
- 4 The efficiency of a given adsorbent for a given vapor depends upon the specific operating conditions. Therefore, again in contrast to filtration, it is not possible to assign a single efficiency rating to an adsorbent. While it is not possible to predict or guarantee an adsorption efficiency for any specific set of conditions, it is possible to enhance the conditions beneficial to adsorption and avoid conditions which interfere with adsorption. Conditions which aid adsorption are: low temperature, high pressure, low flow rate, and absence of competing vapors (particularly water vapor).

Remove solids and liquids from gas samples

Remove solids from liquid samples

Filtration efficiencies from 5 to 100 micron

316L stainless steel construction

Long life, cleanable filter cartridges

Temperature resistance to 400°F

Up to 200 psid (differential pressure)



Advantages

The Balston Stainless Steel Sintered Metal Filter is suitable for applications which require a durable, low maintenance reusable stainless steel filter. The filter cartridge is constructed of 316 stainless steel with two molded Viton gaskets. It may be installed in select Balston filter housings which are designed to accommodate an 050-11, 100-12, and 100-25 size filter cartridge. The Balston Stainless Steel Sintered Metal Filters may be used in liquid or gas service, to filter particulate sized from 5 micron to 100 micron, depending on the grade of the filter used.

The Balston Stainless Steel Sintered Metal Filter has excellent chemical resistance characteristics.

Installation of the Balston Stainless Steel Sintered Metal Filter is straightforward and requires approximately 2-3 minutes. First, remove the filter bowl from the filter housing into which the filter will be installed. Next, place the molded Viton gaskets on to the ends of the cartridge. For 050-11 elements, make sure the shoulder of the gasket fits snugly onto the outer diameter of the cartridge. Finally, holding the gaskets in place on the cartridge, slide the cartridge on the support core or tie rod of the housing, and reassemble the filter housing.

Check the filter housing for leaks after reassembling.

The Balston Stainless Steel Metal Filter Cartridge should be removed from service and cleaned annually, or when the pressure drop across the filter is significant enough to adversely affect the user's application.

The cartridge may be cleaned by backflushing or ultrasonic methods. After cleaning, visually inspect the filter cartridge to confirm it's integrity for continued service.

Applications

- Samples with heavy loading of solid contaminants
- Removal of heavy, viscous liquids from gas samples
- Prefilters to final high efficiency filters
- Ideal for sample lines that are periodically backflushed
- High temperature applications



Flow Rates (SCFM)		Flow Rates, SCFM, at 2 psi drop at indicated line pressure, psig													
Filter Housing Model	Filter Size	Filter Cartridge Grade	Max Porosity (Micron)	2 psig	20 psig	40 psig	60 psig	80 psig	100 psig	125 psig	160 psig	200 psig	250 psig	300 psig	500 psig
95, 85, 91 Series	050-11	05M	5	0.8	1.6	2.6	3.6	4.4	5.4	6.6	7.8	10	12	15	24
		10M	10	1.2	2.4	3.9	5.4	6.6	8.1	9.9	12	15	19	22	36
		20M	20	1.6	3.2	5.2	7.2	8.8	11	13	16	20	25	30	48
		40M	40	2.4	4.8	7.8	11	13	16	20	23	31	37	44	73
		70M	70	3.4	6.8	11	15	19	23	28	33	43	53	63	103
		00M	100	4.4	8.8	14	20	24	30	36	43	56	68	81	133
31S6, 33S6, 31G, 33G, 37/12	100-12	05M	5	2.4	5.2	8.0	11	14	17	21	24	32	39	47	76
		10M	10	3.6	7.8	12	17	21	26	31	37	48	69	70	114
		20M	20	4.8	10	16	22	28	34	41	49	64	78	93	152
		40M	40	7.2	16	24	33	42	51	62	73	95	118	140	229
		70M	70	10	22	34	47	60	72	88	104	135	167	198	324
		00M	100	13	29	44	61	77	94	113	134	175	216	256	419
41S6, 45S6 41G, 45G 37/25	100-25	05M	5	3.4	7.2	11	16	20	24	29	34	45	55	66	108
		10M	10	5.1	11	17	23	30	36	44	52	68	83	99	161
		20M	20	6.8	14	23	31	40	48	58	69	90	111	132	215
		40M	40	10	22	34	47	59	72	88	103	135	166	197	323
		70M	70	14	31	48	66	84	102	124	146	191	235	280	457
		00M	100	19	40	63	86	109	132	161	189	248	305	362	592

Specifications	
Balston Sintered Metal Filter	
Filter Efficiency	5 micron to 100 micron (nominal) in gas and liquid
Materials of Construction	316L Stainless Steel Cartridge, Viton Gasket
Maximum Temperature	400°F
Maximum Pressure Drop	200 psid (14 bar)
Dimensions (including gaskets)	
050-11 size	.75"D x 2.28"L
100-12 size	1.21"D x 2.48"L
100-25 size	1.21"D x 6.98"L
Shipping Weight	0.5 lb. (0.2 kg)

Sintered Stainless Steel Cartridges			
Filter Housing Model	Filter Size	Filter Cartridge Grade	Water Flow Rate in GPH at 1 PSI pressure drop
95, 85, 91	050-11	05M	11
		10M	26
		20M	30
		40M	35
		70M	38
		00M	38
31S6, 33S6 31G, 33G 37/12	100-12	05M	26
		10M	62
		20M	71
		40M	82
		70M	93
		00M	93
41S6, 45S6 41G, 45G 37/25	100-25	05M	61
		10M	111
		20M	128
		40M	148
		70M	154
		00M	154

Ordering Information for assistance, call 800-343-4048. 8am to 5pm Eastern Time.			
	050-11 Size	100-12 Size	100-25 Size
Sintered Metal Filter	050-11-()	100-12-()	100-25-()
Replacement Viton Gaskets	A05-0045	A05-0046	A05-0047
Example: 100-12-40M			

Chemical and Temperature Resistance of Filter Cartridges (For Temperatures Up To 75°F/24°C)*

Chemical or Solvent	X-Type or Q-Type with Fluorocarbon Resin Binder	H-Type With Quartz Construction	LP Cartridge With Polypropylene Support
Cold Water	Excellent	Fair	Excellent
Hot Water (to 180°F/82°C)	Excellent	Not Recommended	Excellent
Steam (to 20 psig)	Excellent	Not Recommended	Not Recommended
Acids, except Hydrofluoric:			
Dilute concentrations	Excellent	Excellent	Excellent
Intermediate concentrations	Excellent	Excellent	Good
Concentrated, except phosphoric	Good-Fair	Excellent	Not Recommended
Concentrated phosphoric acid	Not Recommended	Not Recommended	Not Recommended
Hydrofluoric Acid	Not Recommended	Not Recommended	Not Recommended
Caustic, below 45%	Excellent	Not Recommended	Fair
Caustic, above 45%	Fair	Not Recommended	Not Recommended
Chlorine, liquid or gas	Excellent	Excellent	Not Recommended
Ammonia, liquid or gas	Not Recommended	Not Recommended	Fair
Ethylene Oxide, liquid or gas	Not Recommended	Not Recommended	See Pack 5
Aromatic Hydrocarbons	Excellent	Excellent	Good
All other Hydrocarbons	Excellent	Excellent	Excellent
Ketones	Not Recommended	Excellent	Fair
Alcohols	Excellent	Excellent	Excellent
Freons	Excellent	Excellent	Not Recommended
Phenol	Excellent	Excellent	Not Recommended
Chlorinated Solvents	Excellent	Excellent	Fair
Ethylene Diamine	Excellent	Excellent	Not Recommended
Ethanolamine	Not Recommended	Excellent	Not Recommended
Other Amines	Good-Fair	Excellent	Not Recommended
Polar Solvents, including: DMF, DMAC, NMP, DMSO	Not Recommended	Excellent	Not Recommended
Maximum Operating Temperature	300°F (150°C)	1000°F (538°F)	180°F (82°C)

*Consult factory for compatibility at elevated temperatures

Application Index

Operating Requirement	Filter Cartridge Type	Stainless Steel, Monel, or Aluminum Housing	Plastic Housing
Severe Operating Conditions			
Pressure 250 to 5000 psig	All	91S6, 97S6, 95M, 85, 37/12, 37/25, 27/35, 27/80, 95S6, 95A, 48S6, 49S6, 105S6, 47S6	N/A
Temperature 300°F (150°C) to 600°F (315°C)	H, M	Any stainless steel or Monel housing with Viton seals	N/A
Temperature 600°F (315°C) to 900°F (480°C)	H, M	30/12, 30/25	N/A
Exceptional Chemical Resistance	See chart above	95M/Monel	9922-□-□, 8822□-□/PVDF, 95T/Teflon, 90/Polypropylene
NACE Compliance	All	95S6, 85, 37/12, 37/25, 27/35, 27/80	NA
FUNCTIONAL REQUIREMENTS			
Separate liquids from gases	XE, Q	All housings except 97S6, 30/12, 30/25, 48S6, 49S6, 47S6	8822-11, 8833-11, 95T
Separate two liquid phases	XE, LP	All housings except 97S6, 30/12, 30/25, 48S6, 49S6, 47S6	8822-11, 8833-11, 95T
Remove gas bubbles from liquids	XE, Q	All housings except 97S6, 30/12, 30/25, 48S6, 49S6, 47S6	8822-11, 95T
Quantitative measurement of solids in gases	H, Q	30/12, 30/25	N/A
Slipstream or Bypass Filtration	XE, Q, LP, M	All housings except 97S6, 30/12, 30/25	8822-11, 95T, 53/18, 53/50
Filter liquids with high solids content	LP, M	All housings	All housings
Filter gas or liquid samples to analyzers	XE, Q, LP, M	All housings	9933-05, 9922-05, 90

Flow Rates For Liquid Filters			Water Flow Rate, Gallons Per Hour						
Filter Housing Model	Volume of Housing Gallons Liters		Initial Pressure Drop	Q or X Cartridges		LP Cartridges			
				DQ, DX	BQ, BX	Grade 10	Grade 20	Grade 30	Grade 50
Stainless Steel, Monel and Teflon Housings									
105S6			1 psi	7	2	—	—	—	—
			5 psi	24	10	—	—	—	—
48S6			1 psi	14	4	—	—	—	—
			5 psi	51	21	—	—	—	—
95M, 95S6, 95T, 95A 91S6, 47S6 85	0.005 .009 0.015	0.02 0.036 0.06	1 psi	18	5	—	—	—	—
			5 psi	64	26	—	—	—	—
31S6	0.026	0.098	1 psi	54	13	—	—	—	—
31G			5 psi	129	56	—	—	—	—
49S6			1 psi	57	14	—	—	—	—
			5 psi	135	60	—	—	—	—
33S6 33G 37/12	0.042	0.16	1 psi	63	16	50	50	40	10
			5 psi	150	66	210	210	180	45
41S6	0.051	0.19	1 psi	95	30	—	—	—	—
41G			5 psi	260	121	—	—	—	—
37/25 45S6 45G	0.111	0.42	1 psi	109	35	75	75	60	15
			5 psi	300	140	300	300	260	65
27/35	0.394	1.49	1 psi	325	90	—	—	—	—
			5 psi	875	400	—	—	—	—
C-0150	0.911	3.45	1 psi	—	—	210	210	210	80
			5 psi	—	—	720	720	720	390
27/80	0.750	2.84	1 psi	390	170	—	—	—	—
			5 psi	990	610	—	—	—	—
15/80S6 (2)			1 psi	1650	720	—	—	—	—
			5 psi	4000	2500	—	—	—	—
C-0195	1.37	5.20	1 psi	—	—	420	420	420	160
			5 psi	—	—	1440	1440	1440	780
Plastic Housings									
9922-05	0.003	0.01	1psi	12	3	—	—	—	—
9933-05			5 psi	30	15	—	—	—	—
8822-11, 8833-11	0.005	0.02	1 psi	18	5	—	—	—	—
9922-11, 9933-11			5 psi	45	26	—	—	—	—
90			1 psi	23	10	—	—	—	—
			5 psi	46	36	—	—	—	—
7700-12	0.034	0.13	1 psi	—	—	50	50	40	10
58P			5 psi	—	—	210	210	180	45
53/18	0.185	0.70	1 psi	—	—	100	100	100	40
			5 psi	—	—	360	360	360	190
53/50	0.346	1.31	1 psi	—	—	210	210	210	80
54/50			5 psi	—	—	720	720	720	390
53/95	0.661	2.50	1 psi	—	—	420	420	420	160
			5 psi	—	—	1440	1440	1440	780

Notes: 1 For liquids with viscosity higher than the viscosity of water (1 centipoise), divide the flow rates in the above table by the viscosity of the liquid in centipoises. Example: For liquid with 10 centipoise viscosity, flow rate with Model 53/50 housing, Grade 50 filter cartridges at 5 psi drop will be 390/10=39 GPH.
 2 Flow rates for Model 15/80S6 are estimated.



Flow Rates for Air and Gas Filters

Filter Housing Model	Volume of Housing (ml)	Filter Tube Grade	Flow Rate (CFM) at 10" Water Press. Drop.																						
			0 psig	2 psig	20 psig	40 psig	60 psig	80 psig	100 psig	125 psig	150 psig	200 psig	250 psig	300 psig	500 psig	750 psig	1000 psig	1500 psig	2000 psig	2500 psig	3000 psig	3500 psig	4000 psig	4500 psig	5000 psig
9922-05 4433-05 9900-05 9933-05	11.33	DQ BQ DAU	0.2	1.2	2.5	3.9	5.4	6.8	8.3	10.1	---	---	---	---	---	---	---	---	---	---	---	---	---	---	---
8833-11 9922-11 9933-11	19.82	DXE BXE DAU	0.4	1.8	3.6	6	8	10	12	14.6	---	---	---	---	---	---	---	---	---	---	---	---	---	---	---
97S6	11.33	DQ BQ	0.7	3	7	10	14	18	22	27	32	41	51	60	99	147	195	290	386	482	578	674	770	886	962
95A, 95M 95S6, 95T 91S6, 47S6	19.82	DQ 0.3	1.5	3.9	8	13	18	22	27	33	39	51	62	74	121	180	239	357	470	590	710	830	940	1060	1180
48S6		DQ BQ	N/A	2.5	10	16	23	28	33	40	47	61	75	89	145	210	280	420	560	700	840	980	1120	1260	1400
85	59.47	DXE BXE	N/A	2	5	8	9	10	11	13	16	20	25	29	46	70	90	130	180	220	260	300	340	380	420
90		DXE BQ, BXE	2.2	5.9	12	19.5	26	32	41	50	58	76	92	111	182	270	360	540	710	890	1065	1245	1420	1600	1770
31S6, 31G	93.45	DXE BQ, BXE	0.4	2.2	4.6	7.7	10	12	15	18	22	28	34	41	68	113	134	200	265	325	400	475	530	590	660
30/12, 33S6 33G, 37/12	158.58	DXE BXE	3.0	12	26	40	55	70	85	103	122	159	196	233	381	567	752	1122	1493	1863	2234	2600	2970	3340	3710
49S6		DQ BQ	0.5	3	7	10	14	18	22	27	32	41	51	60	99	147	195	291	387	483	579	695	770	845	920
41S6, 41G	220.87	DXE BQ, DXE	N/A	13	28	45	61	78	94	115	135	177	218	259	423	629	834	1245	1656	2067	2478	2889	3300	3711	4122
30/25 45S6, 45G 37/25	419.09	DXE BQ, BXE	6.6	15	32	50	69	87	106	129	152	199	245	291	477	711	945	1389	1833	2277	2721	3165	3609	4053	4497
27/35 26/35	1500.80	DXE BXE	1.1	7	15	24	32	41	50	61	72	93	115	139	225	332	440	548	656	764	872	980	1088	1196	1304
27/80	2860.02	DXE BXE	7.5	17	36	57	78	99	120	146	172	225	277	329	538	800	1062	1585	2108	2631	3156	3680	4200	4720	5240
15/80S6	4700	DXE BXE	1.3	8	17	26	36	45	55	67	79	103	127	151	247	367	487	607	727	847	967	1087	1207	1327	1447
		DXE BXE	13.3	40	83	130	178	225	273	332	392	510	629	748	1220	1820	2410	3600	4780	5970	7160	8340	9530	10720	11900
		DXE BXE	3.3	19	39	62	84	107	129	157	185	241	297	353	578	858	1140	1700	2260	2820	3380	3940	4500	5060	5630
		DXE BXE	20.0	43	90	142	193	245	297	362	426	555	684	814	1330	1980	2625	3900	5175	6450	7725	9000	10275	11550	12825
		DXE BXE	5.8	28	59	93	127	161	195	237	280	365	449	534	873	1300	1722	2540	3358	4176	5000	5820	6640	7460	8280
		DXE BXE	20.0	160	333	525	717	908	1100	1340	1580	2060	2540	3020	4940	7360	9780	14160	18540	22920	27300	31680	36060	40440	44820
		DXE BXE	5.8	45	94	148	202	256	310	378	445	580	715	850	1390	2080	2770	4100	5430	6760	8090	9420	10750	12080	13410

NA = DATA NOT AVAILABLE 1 For line pressures above 150 PSIG, consult factory for total system pressure drop at operating conditions



Stainless steel construction

Pressure to 5000 psig

Temperature to 900°F (482°C)

Ideal end use filter

Model 97S6

Miniature 316 stainless steel filter with 1/4" NPT in-line ports, and 5000 psig rating. Since it does not have a drain port, the Model 97S6 is used as an end-of-the-line compressed gas filter when little or no liquid is expected, or as a cylinder gas filter.



Model 97S6



Model 30/12 and 30/25

Models 30/12 and 30/25

Designed specifically for quantitative measurement of solids in gases to 900°F (482°C), the filter cartridge and element retainer disc in the Model 30 housings may be weighed as a unit (see notes below).

Principal Specifications			
Model	97S6	30/12	30/25
Inlet and Outlet Ports	1/4" NPT	1/2" NPT	1/2" NPT
Drain Port	None	None	None
Materials of Construction			
Head	316SS	303SS	303SS
Bowl	316SS	304SS	304SS
Internals	316SS	303SS	303SS
Seals	Viton	Carbon Fiber	Carbon Fiber
Maximum Temperature	400°F (204°C)	900°F (482°C) (2)	900°F (482°C)(2)
Maximum Pressure	5000 psig (1)	100 psig (3)	100 psig (3)
Shipping Weight	0.75 lbs. (0.3 kg)	2 lbs. (0.9 kg)	3 lbs. (1.4 kg)
Dimensions	1.25"D X 3.1"L (3.2cm X 7.9cm)	1.9"D X 4.4"L (4.8cm X 11.2cm)	1.9"D X 8.6"L (4.8cm X 22cm)

Notes:

- 1 Maximum pressure ratings are for temperatures to 200°F (93°C). Please consult factory for maximum pressure ratings at elevated temperatures.
- 2 15 psi pressure rating is for temperature to 900°F (482°C).
- 3 100 psig at 450°F (241°C).

Ordering Information			
	For assistance, call toll-free at 1-800-343-4048 8AM to 5PM Eastern Time		
Filter Housing Model	97S6	30/12	30/25
Support Core, Required for Liquid Filtration	Included	N/A	N/A
Filter Cartridges	050-05-□	100-12-□	100-25-□
Important Notes:	X-type cartridges are not available for the Model 97S6. For high temperature quantitative measurement applications order 100-12-DH/BH-F896 for use with the 30/12 or 100-25-DH/BH-F896 for use with the 30/25.		



Prevent cross-contamination of samples

Pressure ratings up to 125 psig

Temperature to 275°F (135°C)

Completely disposable, constructed of recyclable plastics

Models 9922-05, 9933-05, 4433-05 and 9900-05

The 99XX-05 models are the smallest Disposable Filter Units with 11.7 ml internal volume. These models are used in low flow gas or liquid sampling applications, such as liquids to specific-ion analyzers or gases to personal samplers. The model 9900-05-BK has a color indicating feature, which turns the cartridge red when saturated with oil. The model 4433-05 has 1/4" and 3/8" Barb Connections molded into the inlet/outlet ports.

Models 9922-11 and 9933-11

Models 9922-11 and 9933-11 are used for applications similar to the smaller DFUs (Models 9922-05 and 9933-05) which require greater solids holding capacity and can tolerate the increased retention time.

Model 8833-11

These Disposable Filter Units are used as continuous coalescing filters with a third port serving as the drain, slip-stream, or by-pass port.

Chemical Compatibility, Model 9922-05, 9922-11

Suitable: Water or steam to 200°F (135°C); concentrated nitric, sulfuric, and hydrochloric acids; chlorine (gas or liquid); sodium hypochlorite, ethylene oxide (gas or liquid); Freons; ammonia (gas, liquid, or aqueous solutions); hydrogen peroxide (all concentrations); bromine (dry and aqueous solutions); all chlorinated solvents except methylene chloride; all aromatic and aliphatic solvents; all alcohols and glycols; aniline; phenol.
Limited Use: Acetone, MEK, dioxane, furfural, methylene chloride.
Unsuitable: Water above 200°F (135°C), THF, DMF, ethylene diamine, chlorosulfonic acid, ethanolamine, pyridine, sulfur trioxide.



Model 99XX-05



Model 4433-05



Model 9922-11



Model 8833-11

Chemical Compatibility, Model 9933-11

Suitable: Water to 158°F (70°C); benzene, toluene, other aromatic hydrocarbons; hydrocarbon solvents and fuels, perchloroethylene; trichloroethylene, nitric acid (to 10%); sulfuric acid (to 40%); hydrochloric acid (to 10%); most salt solutions; sodium and potassium hydroxide (to 50%).
Limited Use: Water at 176°F (80°C); acetone; MEK, acetaldehyde; ammonia (to 25%).
Unsuitable: Water above 158°F (70°C). alcohols; glycols, phenol; aniline; DMF; concentrated acids; chlorine.

Parker Hannifin offers a manual drain valve for removal of coalesced liquids from the Type 8833-11-DX.

Drain Valve: 1/8" NPT (male) x 1/8" ID Tubing. (Requires elbow part No. 11972). Part No. 20-125

Flow Rates		Water Flow Rate, Gallons per Hour							
DFU Model	Volume of Gallons	Housing Liters	Initial Pressure Drop	Grade DQ, DX	Grade CQ, CX	Grade BQ, BX	Grade AQ	Grade AAQ	
9922-05	0.003	0.01	1 psi	12	10	3	1.5	0.4	
4433-05 9933-05			5 psi	30	25	15	7.3	1.9	
9922-11	0.0005	0.02	1 psi	18	15	5	2.5	0.6	
9933-11			5 psi	45	37	26	12	3.1	

Flow Rates		Air Flow at 2 psi drop, standard, cu. ft. per min. (SCFM) at indicated line pressure.						
Model	2 psig	20 psig	40 psig	60 psig	80 psig	100 psig	125 psig	
8833-11-DX	1.8	3.6	5.8	8.0	10.0	12.0	14.6	
8833-11-BX	0.9	1.8	2.9	4.0	5.0	6.0	7.3	
9900-05-BK	0.4	0.8	1.3	1.8	2.2	2.7	3.3	
4433-05-BX								

Principal Specifications							
Model	9922-05	9900-05	4433-05	9933-05	9922-11	9933-11	8833-11
Inlet and Outlet Ports	1/4" Tubing	1/4" Tubing	1st Tier/Barb 1/4" Tube 2nd Tier/Barb 3/8" Tube	1/4" Tubing	1/4" Tubing	1/4" Tubing	1/4" Tubing
Drain	None	None	None	None	None	None	1/4" Tubing
Material of Construction	PVDF	Nylon	Nylon	Nylon	PVDF	Nylon	Nylon
Filter Cartridge Length	1.25" (3.2 cm)	1.25" (3.2 cm)	1.25" (3.2 cm)	1.25" (3.2 cm)	2.25" (5.7 cm)	2.25" (5.7 cm)	2.25" (5.7 cm)
Maximum Temperature (1)	275°F (135°C)	230°F (110°C)	230°F (110°C)	230°F (110°C)	275°F (135°C)	230°F (110°C)	230°F (110°C)
Maximum Pressure (2)	125 psig	125 psig	125 psig	125 psig	125 psig	125 psig	125 psig
Dimensions	1.0"D X 3.25"L (2.5 cm X 8 cm)	1.0"D X 3.25"L (2.5 cm X 8 cm)	1.0"D X 3.43"L (2.5 cm X 8.72 cm)	1.0"D X 3.25"L (2.5 cm X 8 cm)	1.4"D X 4.6"L (3.6 cm X 12 cm)	1.4"D X 4.6"L (3.6 cm X 12 cm)	1.4"D X 4.6"L (3.6 cm X 12 cm)

Ordering Information		For assistance, call toll-free at 1-800-343-4048 8AM to 5PM Eastern Time						
Model	9922-05	9900-05	4433-05	9933-05	9922-11	9933-11	8833-11	
Box of 10 DFUs	9922-05-□	9900-05-□	4433-05-□	9933-05-□	9922-11-□	9933-11-□	8833-11-□ (4)	
Available only in Q-grades								
Box 10 DAU'S (3)	9922-05-□	N/A	4433-05-□	9933-05-□	9922-11-□	9933-11-□	N/A	

Notes:

- 1 At 0 psig
2 At 110°F (43°C)
3 To designate adsorbent in the DAU, insert adsorbent numbers after DAU designation. For example, to obtain a miniature clear nylon DAU with carbon adsorbent, order 9933-05-000. Adsorbent numbers are listed on page 28.

Installation Information

To pressure pipe or tubing: Compression fittings for 1/4" O.D. tubing may be obtained from the following manufacturers. Hoke, Inc. ("Gyrolok"); Crawford Fitting Co. ("Swagelok"); Parker-Hannifin Corp. ("CPI"); Legris, Inc. (push-on fittings); Jaco Mfg. Co. (plastic fittings).

The following brass fittings which seal by O-ring compression and which may be completely recovered and reused when changing filters may be purchased from Parker/Balston:

Connector: 1/4" tubing to 1/4" NPT female -
Part No. 11970 (1 per pkg.)

Connector: 1/4" tubing to 1/4" tubing -
Part No. 11971 (1 per pkg.)

To low pressure plastic tubing: Tubing with 1/4" ID may be slipped over the DFU and fittings and held with tubing clamps. Parker Hannifin supplies plastic barbs to connect the DFU to smaller diameter plastic tubing. The connection is suitable for pressures to 50 psig.

DFU to 1/16" ID tubing: Part No. 14000 (bag of 20 barbs)

DFU to 1/8" ID tubing: Part No. 14001 (bag of 20 barbs)

Stainless steel construction

Pressure to 5000 psig

Temperature to 400°F (204°C)

Ideal for high pressure applications

Models 27/35, 27/80 and 15/80S6

Model 27 housings are among the largest 316 stainless steel filters available with high pressure capability. The 27/35 and 27/80 housings are used when 800 psig rating is required. The 27/35-3000 and 27/80-3000 models are suitable for service up to 3000 psig. The Model 15/80S6 is designed for 2" pipe systems and pressures to 500 psig.

Models 26/35D-3000 and 26/35D-5000

Model 26/35D filter housings are constructed of carbon steel for high pressure applications. The Model 26/35D-3000 is ASME Code stamped at the rated pressure of 3000 psig. The Model 26/35D-5000 complies with ASME Code design criteria.



Models 27/35 and 27/80
(27/35 Shown)



Models 26/35D-3000
and 26/35D-5000

Principal Specifications						
Model	27/35	27/35-3000	27/80	27/80-3000	26/35D-3000,	15/80S6 26/35D-5000
Inlet and Outlet Ports	1" NPT	1" NPT	1" NPT	1" NPT	1" NPT	2" NPT
Drain Port	1/4" NPT	1/4" NPT	1/4" NPT	1/4" NPT	1/4" NPT	1/4" NPT
Materials of Construction						
Head	316SS (1)	316SS (1)	316SS (1)	316SS (1)	Carbon Steel	Stainless Steel
Bowl	316SS (1)	316SS (1)	316SS (1)	316SS (1)	Carbon Steel	Stainless Steel
Internals	316SS (1)	316SS (1)	316SS (1)	316SS (1)	Stainless Steel	Stainless Steel
Seals	Viton	Viton	Viton	Viton	Buna-N	Viton
Maximum Temperature	400°F(204°C)	400°F(204°C)	400°F(204°C)	400°F(204°C)	250°F(120°C)	400°F(204°C)
Maximum Pressure	800 psig (2)	3000 psig (2)	800 psig (2)	3000 psig (2)	3000 psig (3)	500 psig (2)
Shipping Weight	16 lbs (7.3 kg)	25 lbs. (11 kg)	33 lbs. (14.9 kg)	42 lbs. (19kg)	80 lbs. (36 kg) (4)	32 lbs. (14.4 kg)
Dimensions	4.0"D X 16"L (10 cm X 41 cm)	4.3"D X 16"L (11 cm X 41 cm)	4.0"D X 27"L (10 cm X 69 cm)	4.3"D X 27"L (11 cm X 69 cm)	7.0"D X 17"L (18 cm X 93 cm)	6.3"D X 28"L (16 cm X 71 cm)

Ordering Information For assistance, call toll-free at 1-800-343-4048 8AM to 5PM Eastern Time						
Filter Housing Model	27/35	27/35-3000	27/80	27/80-3000	26/35D-3000,	15/80S6 26/35D-5000
Support Core, Required						
for Liquid Filtration	SS-200-35	SS-200-35	SS-200-80	SS-200-80	Included	SS-200-80
Filter Cartridges	200-35-□	200-35-□	200-80-□	200-80-□	200-35-□	200-80-□
Use only these cartridge types	XE, H, Q, CI (5)	XE, H, Q, CI (5)	XE, H, Q, CI (5)	XE, H, Q, CI (5)	XE, H, Q, CI (5)	XE,H,Q,CI(5)

Notes:

1 Constructed of materials which comply with NACE Specification MR-01-75. Request certificate of compliance

2 Maximum pressure ratings are for temperatures to 200°F (93°C). Please consult factory for maximum pressure ratings at elevated temperatures.

3 Vessel is ASME Section VIII, Div. 1 code stamped for rated pressure at 200°F (93°C). For 5000 psig pressure rating without the ASME code stamp, order Model 26/35D-5000.

4 Shipping weight of Model 26/35-5000 is 170 lbs (77kg)

5 To order CI Cartridges, indicate type of adsorbent desired by putting three digit designation after size code. For example, to order a carbon cartridge for Model 27/35 housing, order CI-200-35-000. CI cartridges are sold in boxes of 1.



Stainless steel construction

Pressure to 5000 psig

Temperature to 400°F (204°C)

Ideal for removing solids and large quantities of liquids from gas

Model 85

The Model 85 filter housing is constructed of 316 stainless steel, and has a pressure rating of 5,000 psig. This Model can accommodate extended life, X-type filter cartridges and is used when larger quantities of liquids are expected.

Models 37/12 and 37/25

These T-type filter housings are also constructed of 316 stainless steel, and have a 4000 psig rating. These models are used as sample filters for on-line sample analyzers when a larger line size, higher flow rate, or larger bowl reservoir capacity is required.



Model 85



Models 37/12, 37/25
(37/25 Shown)

Principal Specifications			
Model	85	37/12	37/25
Inlet and Outlet Ports	1/4" NPT	1/2" NPT	1/2" NPT
Drain Port	1/4" NPT	1/8" NPT	1/8" NPT
Materials of Construction			
Head	316SS (1)	316SS (1)	316SS (1)
Bowl	316SS (1)	316SS (1)	316SS (1)
Internals	316SS (1)	316SS (1)	316SS (1)
Seals	Viton	Viton	Viton
Maximum Temperature	400°F (204°C)	400°F (204°C)	400°F(204°C)
Maximum Pressure (2)	5000 psig	4000 psig	4000 psig
Shipping Weight	4 lbs. (2 kg)	6 lbs. (3 kg)	10 lbs. (5 kg)
Dimensions	2.5"D X 5"L (6cm X 13cm)	2.75"D X 5.75"L (7cm X 14.6cm)	2.75"D X 10.25" L (7cm X 26cm)

Notes:

- 1 Constructed of materials which comply with NACE Specification MR-01-75. Request certificate of compliance
- 2 Maximum pressure ratings are for temperatures to 200°F (93°C). Please consult factory for maximum pressure ratings at elevated temperatures.
- 3 To order CI Cartridges, indicate type of adsorbent desired by putting three digit designation after size code. For example, to order a carbon cartridge for Model 27/35 housing, order CI-200-35-000. CI cartridges are sold in boxes of 1.

Ordering Information For assistance, call toll-free at 1-800-343-4048 8AM to 5PM Eastern Time			
Filter Housing Model	85	37/12	37/25
Support Core, Required for Liquid Filtration	Included	SS-100-12	SS-100-25
Filter Cartridges	050-11-□	100-12-□	100-25-□
Use only these filter cartridge types (3)	XE, H, Q	XE, H, Q, CI, SMF	XE, H, Q, CI

Stainless steel construction

Pressure to 425 psig

Temperature to 220°F (104°C)

Models 33S6 and 45S6

Models 33S6 and 45S6 Filter Housings are constructed of stainless steel and have 1/2" NPT ports. The Model 33S6 uses a 2 1/2" long filter cartridge, and the Model 45S6 uses a 7" long filter cartridge. Both filters are also available with a transparent Pyrex glass bowl (100 psig rating) with breakage-protecting external plastic shield.



Models 33S6 and 45S6
(45S6 Shown)



Models 33G and 45G
(45G Shown)

Models 33G and 45G

These models offer a transparent Pyrex glass bowl (100 psig rating) with breakage-protecting external plastic shield. They also offer convenient molded gaskets to ensure quick and safe filter change-outs.

Filter Cartridges

X-type cartridges with integral prefilters are recommended for filtration of all liquids with high solids content, including samples from cooling water, well water, and effluent streams.

Principal Specifications

Model	33G	45G	33S6	45S6
Inlet and Outlet Ports (1)	1/2" NPT	1/2" NPT	1/2" NPT	1/2" NPT
Materials of Construction				
Head	316SS	316SS	316SS (5)	316SS (5)
Bowl	Pyrex	Pyrex	316SS (5)	316SS (5)
Internals	316SS	316SS	316SS (5)	316SS (5)
Seals	Viton	Viton	Viton	Viton
Maximum Temperature	160°F (71°C) (2)	160°F (71°C) (2)	400°F (204°C) (3)	400°F (204°C) (3)
Maximum Pressure	100 psig (3)	100 psig (3)	425 psig (3)	250 psig (3)
Shipping Weight	3 lbs. (1.4 kg)	5 lbs. (2.3 kg)	3 lbs. (1.4 kg)	5 lbs. (2.3 kg)
Dimensions	2.6"D X 4.5"L (6.7cm X 12cm)	2.6"D X 9.3"L (6.7cm X 24cm)	2.6"D X 4.5"L (6.6cm X 11.4cm)	2.6"D X 9"L (6.6cm X 22.9cm)

Notes:

1 Also available with 1/4" ports. To order with 1/4" NPT ports, use designation Model 33G-1/4, etc.

2 Limited by maximum temperature of acrylic bowl guards.

3 Maximum pressure ratings are for temperatures to 160°F (71°C). Please

consult factory for maximum pressure ratings at elevated temperatures.

4 Support core for use with X-type cartridges. Flow is outside-inside.

consult factory for maximum pressure ratings at elevated temperatures.

5 Materials comply with NACE Specification MR-01-75. Request certificate of compliance.

Ordering Information

For assistance, call toll-free at 1-800-343-4048 8AM to 5PM Eastern Time

Filter Housing Model	33G	45G	33S6	45S6
Filter Cartridge	100-12-□	100-25-□	100-12-□	100-25-□
Use only these Filter cartridge types	LP, M, XE	LP, XE	LP, F, XE	LP, XE
Support Core (4)	SS-100-12	SS-100-25	SS-100-12	SS-100-25

Stainless steel, Teflon®, or Monel construction

Pressure to 5000 psig

T-type construction allows for non-disruptive maintenance

Ideal sample filters for on-line analyzers

Models 91S6, 95A, 95M, 95S6, 95T, 105S6

These models are miniature T-type filters constructed of 316 stainless steel (5000 psig), Teflon® (150 psig), and other specialty materials. With only 19 ml internal volume and the opportunity for by-pass or slipstream filtration using the drain port as an exit port, the model 95 filters are ideal sample filters for on-line analyzers. The model 105S6 has a small internal volume of 15 ml, which is ideal for applications requiring fast sampling response time.



Models 91S6, 95A, 95M, 95S6, 95T (95S6 Shown)



Model 105S6

* Teflon is a registered trademark of the Dupont company

Principal Specifications						
Model	105S6	91S6	95A	95M	95S6	95T
Inlet and Outlet Ports (1)	1/8" NPT	1/8" NPT	1/8" NPT	1/8" NPT	1/8" NPT	1/8" NPT
Drain Port	1/8" NPT	1/8" NPT	1/8" NPT	1/8" NPT	1/8" NPT	1/8" NPT
Materials of Construction						
Head	316SS (2)	316SS (2)	Aluminum	Monel	316SS (2)	Teflon (2)
Bowl	316SS (2)	316SS (2)	Aluminum	Monel	316SS (2)	Teflon (2)
Internals	316SS (2)	316SS (2)	Aluminum	Teflon	316SS (2)	Teflon (2)
Seals	Viton	Viton	Viton	Viton	Viton	Teflon/Viton
Maximum Temperature	400°F (204°C)	400°F (204°C)	200°F (93°C)	400°F (204°C)	400°F (204°C)	300°F (149°C)
Maximum Pressure (3)	5000 psig	1500 psig	2500 psig	5000 psig	5000 psig	150 psig
Shipping Weight	1 lb. (0.4 kg)	1 lb. (0.4 kg)	0.5 lb. (0.2 kg)	1 lb. (0.4 kg)	1 lb. (0.4 kg)	0.5 lb. (0.2 kg)
Dimensions	1.8"D X 3.3"L (4cm X 8cm)	1.5"D X 3.7"L (3.8cm X 9.4cm)	1.8"D X 4"L (4cm X 10cm)	1.8"D X 4"L (4cm X 10cm)	1.8"D X 4"L (4.6cm X 10.2cm)	1.8"D X 4"L (4.6cm X 10.2cm)

Notes:

1 Also available with 1/4" NPT ports. To order with 1/4" NPT ports, use designation Model 95S6-1/4, etc.

2 Constructed of materials which comply with NACE Specification MR-01-75. Request certificate of compliance.

3 Maximum pressure ratings are for temperatures to 200°F (93°C). Please consult factory for maximum pressure ratings at elevated temperatures.

Ordering Information For assistance, call toll-free at 1-800-343-4048 8AM to 5PM Eastern Time						
Model	105S6	91S6	95A	95M	95S6	95T
Support Core, Required for Liquid Filtration	Included	Included	Included	Included	Included	Included
Filter Cartridges	050-07-□	050-11-□	050-11-□	050-11-□	050-11-□	050-11-□
Use only these filter types	Q, H	Q, H	Q, H	Q, H, M	Q, H, M	Q, H, M

Stainless steel construction

Pressure to 250 psig

Temperature to 400°F (204°C)

Compact design

Models 91S6, 31S6, 31G, 41S6, 41G

These models offer compact designs and half the dead volume of other sample filters resulting in faster sampling times. They are constructed of stainless steel and available with a variety of seals for easy adaptation to demanding applications. If larger amounts of condensate are expected, specify 33 or 45 series.



Models 31G, 41G
(41G Shown)



Models 91S6



Models 31S6, 41S6
(31S6 Shown)

Principal Specifications

Model	91S6	31G	41G	31S6	41S6
Inlet and Outlet Ports (1)	1/8" NPT	1/2" NPT	1/2" NPT	1/2" NPT	1/2" NPT
Drain Port	1/4" NPT	1/4" NPT	1/4" NPT	1/4" NPT	1/4" NPT
Materials of Construction					
Head	316SS (2)	316SS	316SS	316SS	316SS
Bowl	316SS (2)	Pyrex	Pyrex	316SS	316SS
Internals	316SS (2)	316SS	316SS	316SS	316SS
Seals	Viton	Viton	Viton	Viton	Viton
Maximum Temperature	400°F (204°C)	160°F (71°C)	160°F (71°C)	400°F (204°C)	400°F (204°C)
Maximum Pressure (3)	1500 psig	100 psig	100 psig	425 psig	250 psig
Shipping Weight	1 lb. (0.4 kg)	2 lbs/0.9 kg	4 lbs/1.8 kg	3 lbs/1.4 kg	5 lbs/2.3 kg
Dimensions	1.5"D X 3.7"L (3.8cm X 9.4cm)	2.2"D X 5.5"L (5.7cm X 14cm)	2.2"D X 10.0"L (5.7cm X 26cm)	2.25"D X 5.5"L (5.7cm X 14cm)	2.25"D X 10"L (5.7cm X 25.4cm)

Notes:

1 Also available with 1/4" NPT ports. To order with 1/4" NPT ports, use designation Model 31G-1/4 etc.

2 Constructed of materials which comply with NACE Specification MR-01-75. Request certificate of compliance.

3 Maximum pressure ratings are for temperatures to 200°F (104°C). Please consult factory for maximum pressure ratings at elevated temperatures.

Ordering Information For assistance, call toll-free at 1-800-343-4048 8AM to 5PM Eastern Time

Filter Housing Model	91S6	31G	41G	31S6	41S6
Support Core, Required for Liquid Filtration	Included	SS-100-12	SS-100-25	SS-100-12	SS-100-25
Filter Cartridges	050-11-□	100-12-□	100-25-□	100-12-□	100-25-□
Use only these Filter cartridge types	Q, H, M	XE, H, Q, M	XE, H, Q	XE, H, Q, M	XE, H, Q

Stainless steel construction

Pressure to 425 psig

Temperature to 400°F (204°F)

Ideal when a large volume of condensed liquid is expected

Models 33S6, 33G, 45S6, 45G

These models are higher flow rate filters. All models are available with 1/4" or 1/2" NPT ports. These filters are also available with clear Pyrex glass bowls (100 psig rating) with breakage protecting external plastic shields. These housings are useful for gas sampling when a large volume of suspended liquid is expected.



Models 33S6 and 45S6
(45S6 Shown)



Models 33G and 45G
(45G Shown)

Principal Specifications

Model	33G	33S6	45G	45S6
Inlet and Outlet Ports (1)	1/2" NPT	1/2" NPT	1/2" NPT	1/2" NPT
Drain Port	1/8" NPT	1/8" NPT	1/8" NPT	1/8" NPT
Materials of Construction				
Head	316SS	316SS	316SS	316SS
Bowl	Pyrex	316SS	Pyrex	316SS
Internals	316SS	316SS	316SS	316SS
Seals	Viton	Viton	Viton	Viton
Maximum Temperature	160°F (71°C) (2)	400°F (204°C) (3)	160°F (71°C) (2)	400°F (204°C) (3)
Maximum Pressure (2)	100 psig	425 psig	100 psig	250 psig
Shipping Weight	3 lbs./1.4kg	3 lbs./1.4 kg	5 lbs./2.3 kg	5 lbs./2.3 kg
Dimensions	2.6"D X 4.5"L (7cm X 11cm)	2.6"D X 4.5"L (6.6cm X 11.4cm)	2.6"D X 9.3"L (6.6cm X 22.9cm)	2.6"D X 9"L (6.6cm X 22.9cm)

Notes:

1 Also available with 1/4" NPT ports. To order with 1/4" NPT ports, use designation Model 33G-1/4, etc.

2 Limited by maximum temperature of acrylic bowl guards.

3 Maximum pressure ratings are for temperatures to 200°F (93°C). Please consult factory for maximum pressure ratings at elevated temperatures.

4 To order CI Cartridges, indicate type of adsorbent desired by putting three digit designation after size code. For example, to order a carbon cartridge for Model 27/35 housing, order CI-200-35-000. CI cartridges are sold in boxes of 1.

Ordering Information For assistance, call toll-free at 1-800-343-4048 8AM to 5PM Eastern Time

Model	33G	33S6	45G	45S6
Support Core, Required for Liquid Filtration	SS-100-12	SS-100-12	SS-100-25	SS-100-25
Filter Cartridges	100-12-□	100-12-□	100-25-□	100-25-□
Use only these filter cartridge types	XE, H, Q, M, CI	XE, H, Q, M, CI	XE, H, Q, CI, M	XE, H, Q, CI, M

**Filter solids and liquids from gases
with 99.99% efficiency at 0.01 micron**

Liquid filtration efficiency to 1 micron

Temperature to 230°F (110°C)

Model 90

The Model 90 filter holder is designed to accept grade X or Q type filter cartridges. This model is used as the inlet filter on air, gas or liquid sample analyzers. It can also be used as a vent/breather filter on storage vessels. The disposable filter cartridge is easily replaced in the field, requiring no tools.



Model 90

Model 7700

The Model 7700 is constructed of transparent nylon with 1/2" NPT in-line ports. This economical, completely disposable filter can be ordered with any LP cartridge installed.



Model 7700-12



Model 58P

Model 58P

The Model 58P housing has a nylon head and internals and a transparent nylon bowl, and replaceable filter cartridges. It is used for filtration of water or mildly acidic or caustic solutions.

Model 53

The Model 53 housings are constructed of polypropylene, and are designed for a single LP-200 filter cartridge in 5", 10", or 20" lengths. The polypropylene construction provides excellent resistance to non-oxidizing acids, such as HCL in any concentration, sulfuric to 70% concentration, brines, hydrocarbon liquids, alcohols, and concentrated caustic. The Model 53 can be used with certain ketones and chlorinated solvents.



Model 53/18

Model 54

The Model 54 housings have a polypropylene head and a transparent styrene-acrylonitrile (SAN) bowl. The transparent bowl is available only in the 10" length. Model 54 housings are used for filtration of water or mildly acidic solutions at temperatures below 100°F (38°C).



Models 54/50 and 53/50
(53/50 Shown)



Principal Specifications						
Model	90	7700-12	58P	53/18	53/50	54/50
Inlet and Outlet Ports	1/4" Tubing	1/2" NPT	1/4" NPT	3/8" NPT	3/4" NPT	3/4" NPT
Materials of Construction						
Head	Polyprop.	Nylon	Nylon	Polyprop.	Polyprop.	Polyprop.
Bowl	Polyprop.	Nylon	Nylon	Polyprop.	Polyprop.	SAN
Internals	---	---	Nylon	Polyprop.	Polyprop.	Polyprop.
Seals	---	---	EPR	EPR	EPR	EPR
Maximum Temperature	230°F (110°C)	150°F (66°C)	150°F (66°C)	125°F (52°C)	125°F (52°C)	100°F (38°C)
Maximum Pressure (1)	60 psig (2)	75 psig	125 psig	125 psig	125 psig	125 psig
Shipping Weight	0.2 lbs. (0.1 kg)	1 lbs. (0.5 kg)	1lbs. (0.5 kg)	3 lbs. (1.4 kg)	4 lbs. (1.8 kg)	4 lbs. (1.8 kg)
Dimensions	1.4"D X 3.8"L (4cm X 10cm)	2.6"D X 4.9"L (7cm X 12cm)	2.7"D X 6.1"L (7cm X 16cm)	5"D X 6.6"L (11cm X 17cm)	5"D X 12"L (13cm X 30cm)	5"D X 12"L (13cm X 30cm)

Notes:

1 Maximum pressure ratings are for temperatures to 125°F (52°C). Please consult factory for maximum pressure ratings at elevated temperatures.

2 60 psig pressure rating with flow direction from inside to out. Consult factory for other operating conditions.

Ordering Information For assistance, call toll-free at 1-800-343-4048 8AM to 5PM Eastern Time						
Filter Housing	90	7700-12-□	58P	53/18	53/50	54/50
Filter Cartridge	100-12-□	Included	LP-100-12-□	LP-200-18-□	LP-200-50-□	LP-200-50-□

Complete removal of solid particles, condensed water, and oils

Long filter life, even in high use conditions

No effect by the filter on the composition of the gas

Complete resistance to corrosion

Model 58N

The Model 58N housing is a rugged, economical housing with a 1/8" NPT drain. The transparent polycarbonate bowl and the nylon head, tie rod, and element retainer are resistant and non-absorbent to all components of the sample stream. The Balston 58N filter housing has much better corrosion resistance and is more economical than other filters used in this application.

The Balston Grade 404 Microfibre Filter Cartridges were developed specifically for use in sample lines to Gasoline Engine Analyzers. The filter cartridges are composed of borosilicate glass and polyolefin fibers. They have a 93% retention efficiency at 0.1 micron and offer a significantly higher solids holding capacity and lower pressure drop than conventional resin-bonded glass microfibre filter cartridges. The Balston Grade 404 filter cartridges are hydrophobic and drain water much more rapidly than all-glass fiber cartridges, greatly reducing the possibility of loss of NO₂ and other water-soluble components from the gas sample.

When installed with inside-to-outside flow direction, the Grade 404 filter cartridges are efficient, fast-draining coalescing filters. When installed with outside-to-inside flow direction, the pure white surface of the filter tube permits quick visual estimation of the dirt loading on the filter cartridge.

In addition to the standard 100-12 size, Grade 404 Microfibre Filter Cartridges are available in sizes to fit all Vehicle Emission Analyzer filter housings.



Model 58N

Principal Specifications

Model	58N
Inlet and Outlet Ports	1/4" NPT
Drain Port	1/8" NPT
Materials of Construction	
Head	Nylon
Bowl	Polycarbonate
Internals	Nylon
Seals	Buna
Maximum Temperature	150°F (66°C)
Maximum Pressure	10 psig
Shipping Weight	1lb. (0.5 kg)
Dimensions	2.8"D X 6.3"L

Ordering Information

Filter Housing Model	58N
Replacement Filter Cartridges (box of 10)	100-12-404
	Note: Filter cartridge not included. Must be ordered separately



Totally inorganic filter cartridge is inert and contains no extractables

Temperature capability to 450°F (232°C)

Filter housing designed for convenient external heating

The Problem:

Diesel engine exhaust has a much higher concentration of suspended solid particles and nonvolatile liquid droplets.

Diesel engine exhaust has a high dew point and must be kept hot to prevent liquid condensation which would affect the accuracy of the analysis. To avoid contamination of sample lines with dirt and oil, most diesel engine analysis systems are designed with the primary filter close to the inlet of the sample system. The filter is externally heated to prevent liquid condensation when the system is started up, but during prolonged operation, the filter often is subjected to engine exhaust gas temperatures, which normally range from 350°F to 450°F (176°C to 232°C) and occasionally get as high as 600°F (315°C).

The Solution:

Model 38 filters, designed specifically for diesel engine exhaust, are all-stainless steel housings with silicone seals (maximum temperature 600°F/315°C). The 1/4" NPT inlet and outlet ports are located at one end of the cylindrical body, and the bayonet closure for changing the filter cartridge is located at the opposite end. To maintain constant temperature, the body may be wrapped in heating tape or enclosed in an oven. The novel closure design permits an operator wearing gloves to replace a filter element rapidly, without disturbing the heating provisions or gas flow connections. The filter housing may be oriented horizontally, vertically, or at any other convenient attitude.

The standard size Model 38/25 housing has a 10-inch (25 cm) long body. Where the installation requires a smaller size housing, the Model 38/12 with 5 1/2 inch (14 cm) long body is available.

The Grade DH21 filter cartridge, composed of borosilicate glass microfibers and inorganic binder, is inert to all components in the gas and stable to 900°F (482°C). The retention efficiency is 93% of 0.1 micron particles and 100% of 2 micron and larger particles. With flow



Model 38/12, 38/25
(38/25 Shown)

direction through the filter tube inside-to-outside, the internal prefilter in the Grade DH21 cartridge provides satisfactory life in a relatively dirty environment. Since the dirt is trapped on the inside of the cartridge, the external surface of the cartridge and the filter housing remain free of contaminants.

Principal Specifications

Model	38/12	38/25
Inlet and Outlet Ports	1/4" NPT	1/4" NPT
Materials of Construction		
Head	Stainless Steel	Stainless Steel
Bowl	Stainless Steel	Stainless Steel
Internals	Stainless Steel	Stainless Steel
Seals	Silicone	Silicone
Maximum Temperature	450°F (232°C)	450°F (232°C)
Maximum Pressure	20 PSIG	20 PSIG
Shipping Weight	5 lbs. / 2.3 kg	4 lbs. / 1.8 kg
Dimensions (1)	2.25"D X 5.5"L (6cm X 14cm)	2.25"D X 10.0"L (6cm X 25cm)

Ordering Information

Filter Housing Model	Filter Cartridge
38/25 (box of 10) Standard Length	100-25-DH21 (2)
38/12 (box of 10) Short Length	100-12-DH21 (2)
Note: Filter cartridge not included. Must be ordered separately.	

Notes:

1 Dimension without handle. Handle adds 3.75" (9.5 cm).

2 If an H-Type filter cartridge is being used, order a modified element retainer kit, P/N 30205.

Ideal for protecting GCs, Mass Spectrometers, O₂ Analyzers, and Moisture Analyzers

Removes entrained water, submicron sulfuric acid aerosol, and ultra fine particulate

Much lower initial cost and operating costs than other membrane filters



Series 98 Membrane Filter

Series 98 Membrane Filter

The Series 98 Membrane Filter consists of a housing with a porous membrane filter, which is supported by a sintered porous disk located on the "outlet" side of the housing. Gas enters through the "inlet" port on the upstream side of the membrane, and exits from the "outlet" port on the downstream side. Entrained liquid will not flow through the membrane, and will exit through the "bypass" port on the upstream side of the membrane, completely protecting sensitive instrumentation from moisture. Two models are available: The 98-0 (standard) and the 98-2 (high flow). The 98 Series is identical to other hydrophobic membranes offering the same performance and features but at a much lower price.

The Membrane

Microscopic pores contained within the membrane permit molecules of gas or vapor to flow through easily, allowing the composition of the sample gas to remain unchanged. Even the smallest liquid molecules remain trapped and are unable to flow through the membrane's small passages under normal operating conditions. This is due to the high surface tension which causes liquid molecules to bind tightly together to form a group of molecules, moving together, which is too large to fit through the pores of the membrane.

The membrane is extremely inert, and is recommended for most process liquid applications, with the exception of hydrofluoric acid. It is also recommended for use in systems designed for PPB, PPM, and "percent level" component concentrations, as a result of its very low absorption characteristics. The membrane is strong and durable, but also very soft and pliable.

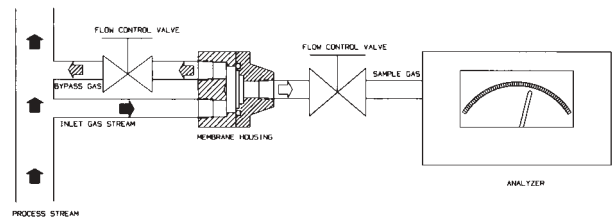

Typical Location of a Balston Membrane Filter in an Analyzer Application

(Note: For the membrane to operate correctly, there must be a bypass flow.)



How to Select the Membrane and Model

1. Determine the following application requirements:
 - A. Gas flow rate to the analyzer excluding the bypass flow.
 - B. Type of suspended liquid to be separated and amount normally present in the sample.
 - C. Gas sample supply pressure at membrane filter inlet.
2. Use Table 1 to select a membrane filter model and membrane type which meet your application requirements. Note that the membrane differential pressure for the model and membrane type selected must be lower than the available gas sample supply pressure.

Selecting the Appropriate Type of Membrane

There are two basic types of membranes for the 98 Series Membrane Filters: The Model 98-0 (Standard) is suitable for separation of most liquids from gases. The Model 98-2 (High Flow) is best suited for the separation of water and other high surface-tension liquids from gases.

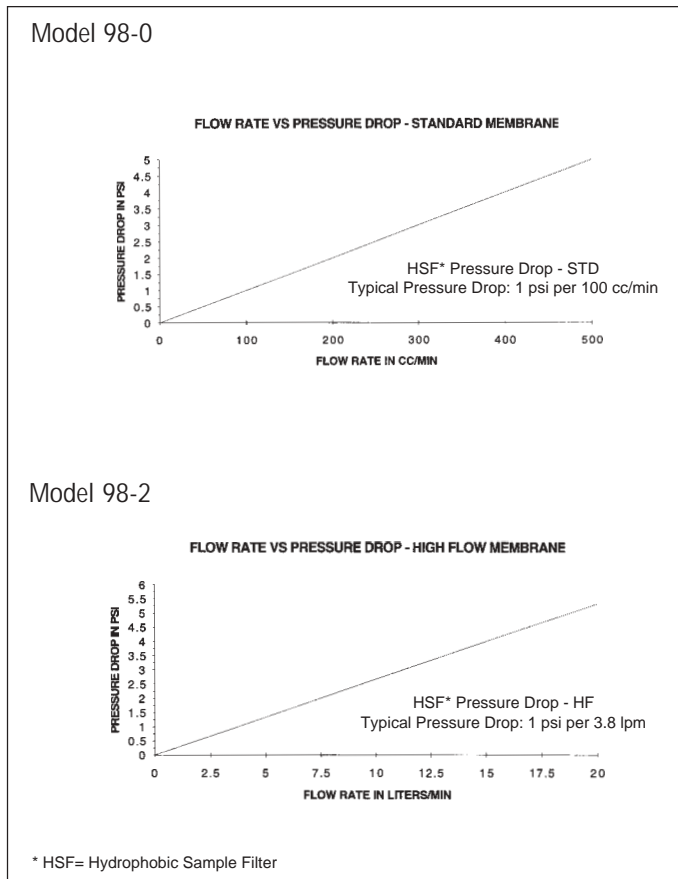

Model	98-0	98-2
Membrane Type	Standard (1)	High Flow (2)
Max. Recommended Flow Rate in L/Min. (3)	0.60	10
Normal Amount of Liquid Present in Gas (4)	Low to Medium	Low to Medium

Notes:

- 1 Standard membrane is suitable for most suspended liquids.
- 2 High flow membrane is suitable for suspended water, solutions consisting primarily of water, sulfuric acid, caustic, glycols, oily liquids, other high surface-tension type liquids.
- 3 Maximum recommended flow rate of gas through the membrane. Does not include the "bypass" flow rate.
- 4 Amount of liquid normally expected to be present in the sample gas: Low: aerosol or occasional droplets. Medium: continuous droplets. High: continuous flowing liquid.

Model	98
Inlet, Outlet, Bypass Ports	1/4" NPT
Materials of Construction	
Housing	316 Stainless Steel (2)
O-rings	Viton (standard) Kalrez, Buna, EPDM (optional)
Maximum Operating Pressure	1000 psig @ 200°F
Maximum Temperature	212°F (100°C)
Maximum Flow Rate	
Standard Membrane	.60 L/Min.
High Flow Membrane	10 L/Min.
Typical Membrane Pressure Drop (1)	
Standard Membrane	1 psig per 100 cc/min. flow through membrane
High Flow Membrane	1 psig per 3.8 liters/min. flow through the membrane
Outside Dimensions	2"D x 2"L (5cm X 5cm)
Shipping Weight	1.5 lbs. (0.7 kg)

Notes:

- 1 Pressure Drops are for temperatures to 212°F (100°C).

Filter Assembly Maintenance Kits	98-0 (Standard)	98-2 (High Flow)
98014	5 each Membranes & Viton O-Rings for 98-0	
98015	5 each Membranes & Viton O-Rings for 98-2	
98002	5 each Membranes 98-0	
98020	5 each Membranes 98-2	

A98 Series offers continuous coalescing of all liquid and the security of hydrophobic membrane protection all in one unit

Fewer fittings required - reducing risk of leaks

More compact - no need for separate coalescers

Less maintenance and downtime as the membrane is fully protected from solids & liquids

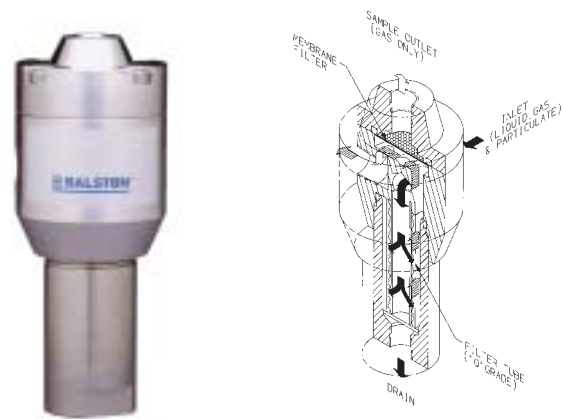

Series A98 Coalescer Membrane
Combination Filter

Series A98 Coalescer Membrane Combination Filter

The Balston Coalescer Membrane Combination Filter is designed to remove entrained liquid and particulate in gas samples for a wide variety of applications, and thereby prevents contamination or damage to the analyzers and sample system components. Typically located upstream from the analyzer or component it is protecting, the Coalescer Membrane Combination provides protection even if other sample system components fail.

The Coalescer Membrane Combination offers the performance and protection of the 98 Series Membrane Filter with the additional benefits of coalescing liquids and entrapment of particulates, offering maximum protection of the membrane. There is no need for prefiltration which places more volume in the sample system, and requires more space for installation and more potential for leaks.

The Series A98 consists of a housing with a porous membrane filter, which is supported by a sintered porous disk located on the "outlet" side of the housing. Gas enters through the "inlet" port and is directed down through the coalescing filter. The coalescer traps all particulates and continuously drains liquid contaminants. The sample gas then flows upward to the upstream side of the membrane, and exits from the "outlet" port on the downstream side. Entrained liquid will not flow through the membrane, and will exit through the drain port on the downstream side of the coalescer.

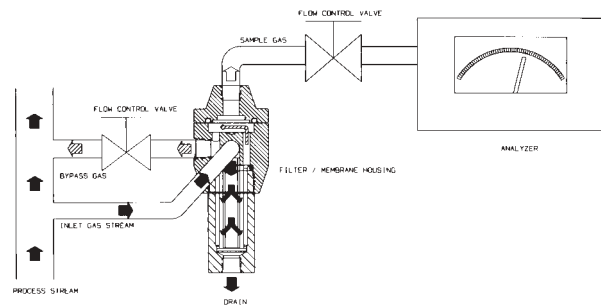

Typical Location of a Balston Membrane Filter
in an Analyzer Application

(Note: For the membrane to operate correctly, there must be a bypass flow.)

The Membrane

Microscopic pores contained within the membrane permit molecules of gas or vapor to flow through easily, allowing the composition of the sample gas to remain unchanged. Even the smallest liquid molecules remain trapped and are unable to flow through the membrane's small passages under normal operating conditions. This is due to the high surface tension which causes liquid molecules to bind tightly together to form a group of molecules, moving together, which is too large to fit through the pores of the membrane.

The membrane is extremely inert, and is recommended for most process liquid applications, with the exception of hydrofluoric acid. It is also recommended for use in systems designed for PPB, PPM, and "percent level" component concentrations, as a result of its very low absorption characteristics. The membrane is strong and durable, but also very soft and pliable.

How to Select the Membrane and Model

1. Determine the following application requirements:

- A. Gas flow rate to the analyzer excluding the bypass flow.
- B. Type of suspended liquid to be separated and amount normally present in the sample.
- C. Gas sample supply pressure at Membrane Filter inlet.

2. Use Table 1 to select a Membrane Filter model and Membrane type which meet your application requirements. Note that the membrane differential pressure for the model and membrane type selected must be lower than the available gas sample supply pressure.

Selecting the Appropriate Type of Membrane

There are two basic types of membranes for the A98/11 Series Membrane Filters: The Model A98/11-__Q-0 (Standard) is suitable for separation of most liquids from gases. The Model A98/11-__Q-2 (High Flow) is best suited for the separation of water and other high surface-tension liquids from gases.

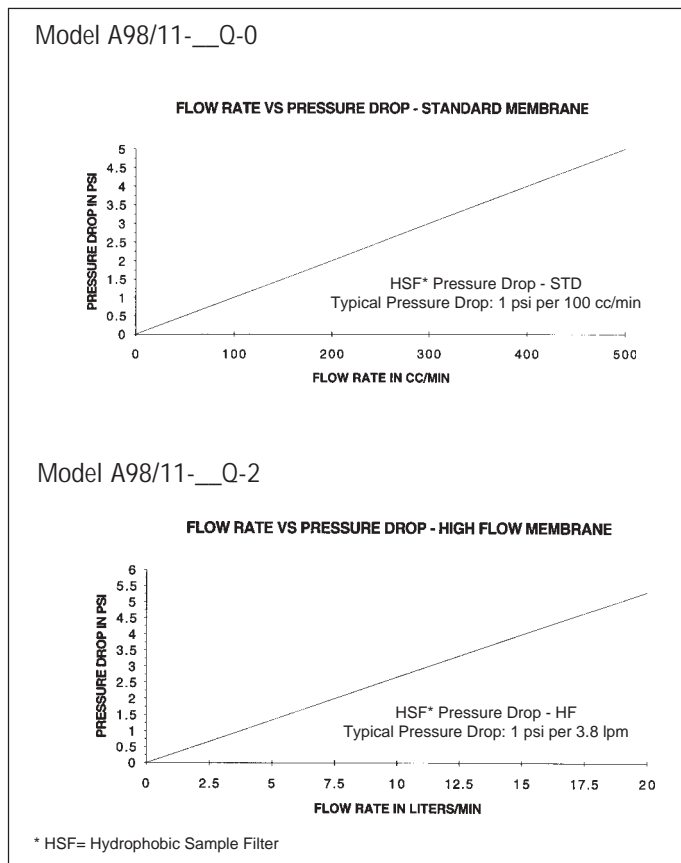

Table 1 Housing and Membrane Selection Guide

Model	A98/11-__Q-0	A98/11-__Q-2
Membrane Type	Standard (1)	High Flow (2)
Max. Recommended Flow Rate in L/Min. (3)	0.60	10
Normal Amount of Liquid Present in Gas (4)	Low to Medium	Low to Medium

Notes:

- 1 Standard membrane is suitable for most suspended liquids.
- 2 High flow membrane is suitable for suspended water, solutions consisting primarily of water, sulfuric acid, caustic, glycols, oily liquids, other high surface-tension type liquids.
- 3 Maximum recommended flow rate of gas through the membrane. Does not include the "bypass" flow rate.
- 4 Amount of liquid normally expected to be present in the sample gas: Low: aerosol or occasional droplets. Medium: continuous droplets. High: continuous flowing liquid.

Principal Specifications

Model	A98/11- [] Q - []
Inlet, Outlet, Bypass Ports	1/4" NPT
Materials of Construction	
Housing	316 Stainless Steel
O-rings	Viton (standard) Kalrez, Buna, EPDM (optional)
Maximum Operating Pressure	1000 psig @ 200°F
Maximum Temperature	212°F (100°C)
Maximum Flow Rate	
Standard Membrane	.60 L/Min.
High Flow Membrane	10 L/Min.
Typical Membrane Pressure Drop (1)	
Standard Membrane	1 psig per 100 cc/min. flow through membrane
High Flow Membrane	1 psig per 3.8 liters/min. flow through the membrane
Outside Dimensions	2"D x 4"L (5cm X 10cm)
Shipping Weight	2.4 lbs. (1.1 kg)

Notes:

- 1 Pressure Drops are for temperatures to 212°F (100°C).
- 2 Constructed of materials which comply with NACE Specification MR-01-75. Request certificate of compliance.

Ordering Information

Filter Assembly	A98/11-__Q-0	A98/11-__Q-2
98011	5 ea. DQ Filters, Viton O-Rings and Membranes for A98/11-DQ-0	
98012	5 ea. BQ Filters, Viton O-Rings and Membranes for A98/11-BQ-2	
98013	5 ea. DQ Filters, Viton O-Rings and Membranes for A98/11-DQ-2	
98010	5 ea. BQ Filters, Viton O-Rings and Membranes for A98/11-bq-0	
98002	5 ea. Membranes for A98-0 or A98/11_Q-0	
98020	5 ea. Membranes for A98-2 or A98/11_Q-2	
050-11-__Q	10 ea. Coalescing Filter Cartridges	

The A39/12 Series offers continuous coalescing of all liquid and the security of hydrophobic membrane protection all in one unit

Fewer fittings required - reducing risk of leaks

More compact - no need for separate coalescers

Less maintenance and downtime as the membrane is fully protected from solids & liquids

Series A39/12 Coalescer Membrane Combination Filter

The Balston Coalescer Membrane Combination Filter is designed to remove entrained liquid and particulate in gas samples for a wide variety of applications, and thereby prevents contamination or damage to the analyzers and sample system components. Typically located upstream from the analyzer or component it is protecting, the Coalescer Membrane Combination provides protection even if other sample system components fail.

The Coalescer Membrane Combination offers the performance and protection of the A39/12 Series Membrane Filter with the additional benefits of coalescing liquids and entrapment of particulates, offering maximum protection of the membrane. There is no need for prefiltration which places more volume in the sample system, and requires more space for installation and more potential for leaks.

The A39/12 Series consists of a housing with a porous membrane filter, which is supported by a sintered porous disk located on the "outlet" side of the housing. Gas enters through the "inlet" port and is directed down through the coalescing filter. The coalescer traps all particulates and continuously drains liquid contaminants. The sample gas then flows upward to the upstream side of the membrane, and exits from the "outlet" port on the downstream side. Entrained liquid will not flow through the membrane, and will exit through the drain port on the downstream side of the coalescer.

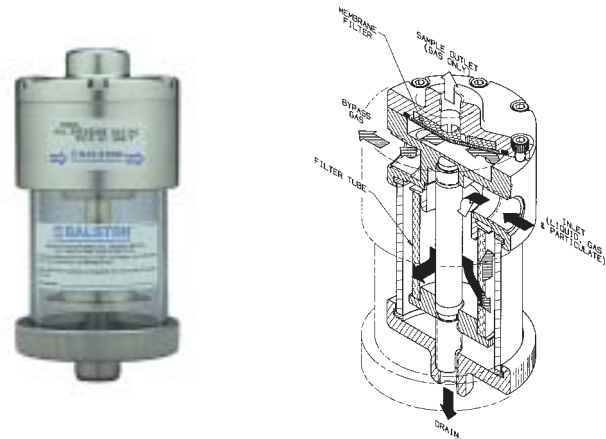

Series A39/12 Coalescer Membrane
Combination Filter

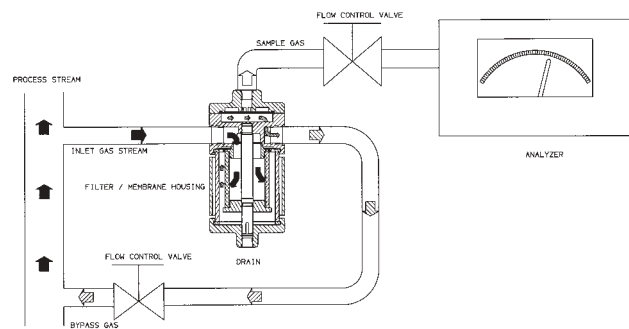

Typical Location of a Balston Membrane Filter
in an Analyzer Application

(Note: For the membrane to operate correctly, there must be a bypass flow.)

The Membrane

Microscopic pores contained within the membrane permit molecules of gas or vapor to flow through easily, allowing the composition of the sample gas to remain unchanged. Even the smallest liquid molecules remain trapped and are unable to flow through the membrane's small passages under normal operating conditions. This is due to the high surface tension which causes liquid molecules to bind tightly together to form a group of molecules, moving together, which is too large to fit through the pores of the membrane.

The membrane is extremely inert, and is recommended for most process liquid applications, with the exception of hydrofluoric acid. It is also recommended for use in systems designed for PPB, PPM, and "percent level" component concentrations, as a result of its very low absorption characteristics. The membrane is strong and durable, but also very soft and pliable.

How to Select the Membrane and Model

1. Determine the following application requirements:
 - A. Gas flow rate to the analyzer excluding the bypass flow.
 - B. Type of suspended liquid to be separated and amount normally present in the sample.
 - C. Gas sample supply pressure at Membrane Filter inlet.
2. Use Table 1 to select a Membrane Filter model and Membrane type which meet your application requirements. Note that the membrane differential pressure for the model and membrane type selected must be lower than the available gas sample supply pressure.

Selecting the Appropriate Type of Membrane

There are two basic types of membranes for the A39/12 Series Membrane Filters: The Model A39/12-0 (Standard) is suitable for separation of most liquids from gases. The Model A39/12-2 (High Flow) is best suited for the separation of water and other high surface-tension liquids from gases. A Pyrex bowl is available which offers full visibility of coalescing chamber.

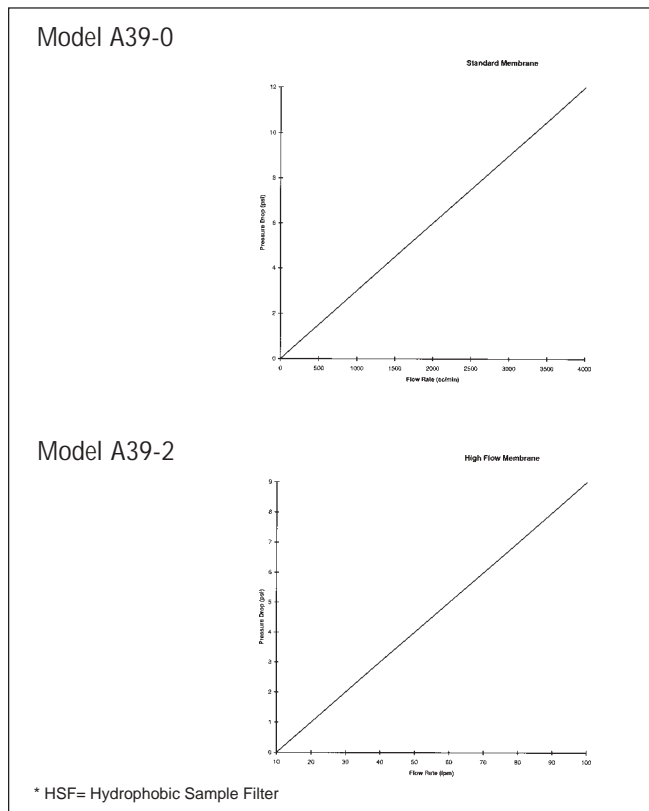

Table 1 Housing and Membrane Selection Guide

Model	A39-0 Series	A39-2 Series
Membrane Type	Standard (1)	High Flow (2)
Max. Recommended Flow Rate in L/Min. (3)	1.0 lpm	70 lpm
Normal Amount of Liquid Present in Gas (4)	Low to Medium	Low to Medium

Notes:

- 1 Standard membrane is suitable for most suspended liquids.
- 2 High flow membrane is suitable for suspended water, solutions consisting primarily of water, sulfuric acid, caustic, glycols, oily liquids, other high surface-tension type liquids.
- 3 Maximum recommended flow rate of gas through the membrane. Does not include the "bypass" flow rate.
- 4 Amount of liquid normally expected to be present in the sample gas: Low: aerosol or occasional droplets. Medium: continuous droplets. High: continuous flowing liquid.

Principal Specifications

Model	A39/12 Series
Bypass Ports	1/2" NPT
Sample Port	1/4" NPT
Materials of Construction	
Housing	316 Stainless Steel (2)
O-rings	Viton (standard) Kalrez, Buna, EPDM (optional)
Maximum Operating Pressure	425 psig @ 200°F (100 psig @ 200°F with Pyrex bowl)
Maximum Temperature	212°F (100°C)
Maximum Flow Rate	
Standard Membrane	1 L/Min.
High Flow Membrane	70 L/Min.
Typical Membrane Pressure Drop (1)	
Standard Membrane	1 psig per 250 cc/min. flow through membrane
High Flow Membrane	1 psig per 20 liters/min. flow through the membrane
Outside Dimensions	3.3"D x 7.3"L (8.4 cm X 18.5 cm)
Shipping Weight	7 lbs. (1.1 kg)

Notes:

- 1 Pressure Drops are for temperatures to 212°F (100°C).
- 2 Constructed of materials which comply with NACE Specification MR-01-75. Request certificate of compliance.

Ordering Information

Filter Assembly	A39/12-__X-0, A39/12-__X-2
39014	5 ea. Viton O-Rings and Membranes for A39/12-0
39015	5 ea. Viton O-Rings and Membranes for A39/12-2
39002	5 ea. Membranes for A39/12-0
39020	5 ea. Membranes for A39/12-2
150-12-__XE	10 ea. Coalescing Filter Cartridges

Notes:

- 1 For Glass Bowl version order: A39/12G-__X-(0)-(2)

Ideal for protecting GCs, Mass Spectrometers, O₂ Analyzers, and Moisture Analyzers

Removes entrained water, submicron sulfuric acid aerosol, and ultra fine particulate

Much lower initial cost and operating costs than other membrane filters



39 Series

The 39 Series Membrane Filter

The 39 Series Membrane Filter consists of a housing with a porous membrane filter, which is supported by a sintered porous disk located on the "outlet" side of the housing. Gas enters through the "inlet" port on the upstream side of the membrane, and exits from the "outlet" port on the downstream side. Entrained liquid will not flow through the membrane, and will exit through the "bypass" port on the upstream side of the membrane, completely protecting sensitive instrumentation from moisture. Two models are available: The 39-0 (standard) and the 39-2 (high flow). The 39 Series is identical to other hydrophobic membranes offering the same performance and features but at a much lower price.

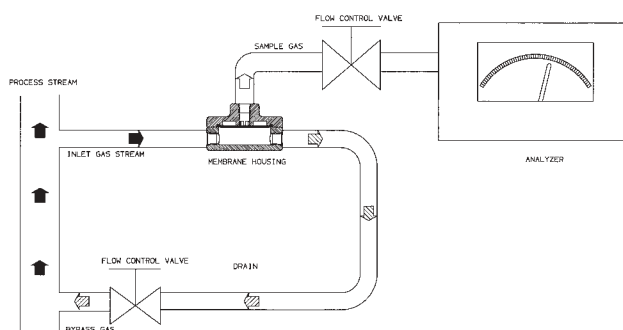

Typical Location of a Balston Membrane Filter in an Analyzer Application

(Note: For the membrane to operate correctly, there must be a bypass flow.)

The Membrane

Microscopic pores contained within the membrane permit molecules of gas or vapor to flow through easily, allowing the composition of the sample gas to remain unchanged. Even the smallest liquid molecules remain trapped and are unable to flow through the membrane's small passages under normal operating conditions. This is due to the high surface tension which causes liquid molecules to bind tightly together to form a group of molecules, moving together, which is too large to fit through the pores of the membrane.

The membrane is extremely inert, and is recommended for most process liquid applications, with the exception of hydrofluoric acid. It is also recommended for use in systems designed for PPB, PPM, and "percent level" component concentrations, as a result of its very low absorption characteristics. The membrane is strong and durable, but also very soft and pliable.



How to Select the Membrane and Model

1. Determine the following application requirements:
 - A. Gas flow rate to the analyzer excluding the bypass flow.
 - B. Type of suspended liquid to be separated and amount normally present in the sample.
 - C. Gas sample supply pressure at membrane filter inlet.
2. Use Table 1 to select a membrane filter model and membrane type which meet your application requirements. Note that the membrane differential pressure for the model and membrane type selected must be lower than the available gas sample supply pressure.

Selecting the Appropriate Type of Membrane

There are two basic types of membranes for the 39-2 Series Membrane Filters: The Model 39-0 (Standard) is suitable for separation of most liquids from gases. The Model 39-2 (High Flow) is best suited for the separation of water and other high surface-tension liquids from gases.

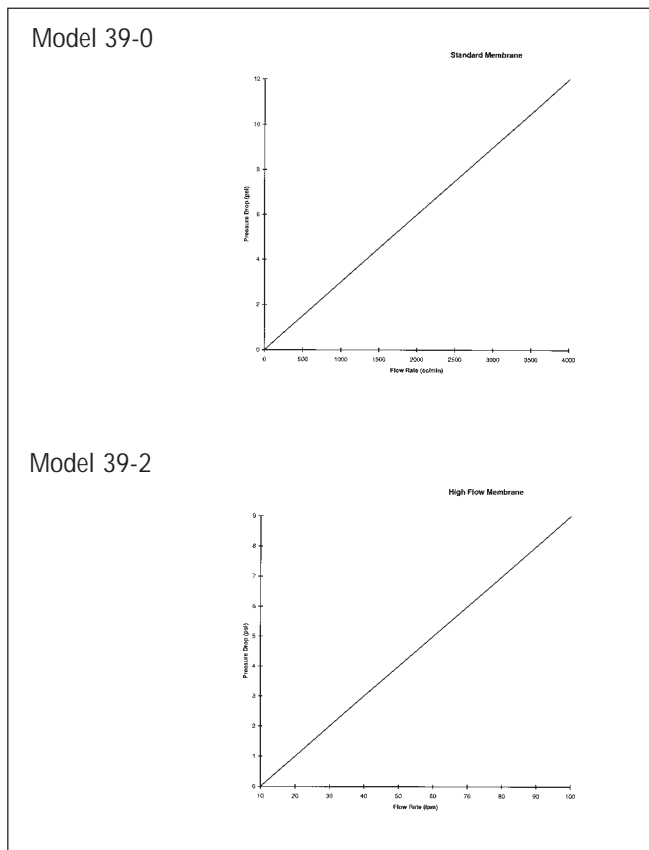

Model	39-0	39-2 Series
Membrane Type	Standard (1)	High Flow (2)
Max. Recommended Flow Rate in L/Min. (3)	1.0 lpm	70 lpm
Normal Amount of Liquid Present in Gas (4)	Low to Medium	Low to Medium

Notes:

- 1 Standard membrane is suitable for most suspended liquids.
- 2 High flow membrane is suitable for suspended water, solutions consisting primarily of water, sulfuric acid, caustic, glycols, oily liquids, other high surface-tension type liquids.
- 3 Maximum recommended flow rate of gas through the membrane. Does not include the "bypass" flow rate.
- 4 Amount of liquid normally expected to be present in the sample gas: Low: aerosol or occasional droplets. Medium: continuous droplets. High: continuous flowing liquid.

Model	39 Series
Bypass Ports	1/2" NPT
Sample Port	1/4" NPT
Materials of Construction	
Housing	316 Stainless Steel (2)
O-rings	Viton (standard) Kalrez, Buna, EPDM (optional)
Maximum Operating Pressure	500 psig @ 200°F (100 psig @ 200°F with Pyrex bowl)
Maximum Temperature	212°F (100°C)
Maximum Flow Rate	
Standard Membrane	1 L/Min.
High Flow Membrane	70 L/Min.
Typical Membrane Pressure Drop (1)	
Standard Membrane	1 psig per 250 cc/min. flow through membrane
High Flow Membrane	1 psig per 20 liters/min. flow through the membrane
Outside Dimensions	3.3"D x 2"L (8.4cm X 5.1cm)
Shipping Weight	3 lbs.

Notes:

- 1 Pressure Drops are for temperatures to 212°F (100°C).
- 2 Constructed of materials which comply with NACE Specification MR-01-75. Request certificate of compliance.

Filter Assembly	39-0, 39-2
39014	5 ea. Viton O-Rings and Membranes for 39-0
39015	5 ea. Viton O-Rings and Membranes for 39-2
39002	5 ea. Membranes for 39-0
39020	5 ea. Membranes for 39-2

All 316 Stainless steel/Pyrex construction

Accepts Balston disposable microfibre filter cartridge and stainless steel cartridge

Compact design for fast response time

Process stream inlet/outlet ports and sample flow ports are identical, eliminating backup pressure in the system

Description

Balston fast loop filters are constructed of 316 stainless steel with an optional stainless steel bowl or pyrex bowl. This flow through design continuously flushes the filter cartridge carrying the contaminants back out to the process stream, thus maximizing the filter cartridge life. The low flow sample stream pulled into the analyzer is filtered to ranges of 100 micron to 0.01 micron (depending on the filtration efficiency required). Two designs are available. The T-type design is suitable for high flow, high volume applications. The In-line design is ideal for heavily contaminated applications.

Operation

Axial velocity flushes the bulk contaminants through the filter housing back to the process stream. The sample stream passes through the filter cartridge wall with low flow and radial velocity. The clean side of the sample filter system has very low volume which minimizes lag time. A four to one flow rate is recommended to realize the benefits of prolonged filter cartridge life associated with continuous flushing.



Model 41GCFL-1/4



Model 48S6



Model 49S6



Principal Specifications						
Model	31GCFL-1/4	31S6CFL-1/4	41GCFL-1/4	41S6CFL-1/4	48S6	49S6
Inlet and Outlet Ports	1/4" NPT	1/4" NPT	1/4" NPT	1/4" NPT	1/4" NPT	1/2" NPT
Drain Port	1/4" NPT	1/4" NPT	1/4" NPT	1/4" NPT	---	---
Materials of Construction						
Head	316 SS	316 SS (2)	316 SS	316 SS (2)	316 SS (2)	316 SS (2)
Bowl (1)	Pyrex	316SS (2)	Pyrex	316 SS (2)	316 SS (2)	316 SS (2)
Internals	316SS	316 SS (2)	316 SS	316 SS (2)	316 SS (2)	316 SS (2)
Seals	Viton	Viton	Viton	Viton	Viton	Viton
Maximum Temperature	160°F (71°C)	400°F (204°C)	160°F (71°C)	400°F (204°C)	400°F (204°C)	400°F (204°C)
Maximum Pressure (2)	100 psig	425 psig	100 psig	250 psig	5,000 psig	1,500 psig
Shipping Weight	2 lbs/0.9 kg	3 lbs/1.4 kg	4 lbs/1.8 kg	5 lbs/2.3 kg	1.1 lbs/0.2 kg	2.5 lbs/0.4 kg
Dimensions	2.2"D x 5.5"L (5.7cm x 14cm)	2.2"D x 5.5"L (5.7cm x 14cm)	2.2"D x 10"L (5.7cm x 25cm)	2.2"D x 10"L (5.7cm x 25cm)	1.35"D x 4"L (3.2cm x 10cm)	1.9"D x 7"L (4.8cm x 17.8cm)

Notes:

1 Maximum pressure ratings are for temperatures to 200°F (104°C). Please consult factory for maximum pressure ratings at elevated temperatures.

2 Constructed of materials which comply with NACE Specification MR-01-75. Request certificate of compliance.

Ordering Information						
For Assistance, call toll-free at 1-800-343-4048 8AM to 5PM Eastern Time						
Filter Housing Model	31GCFL-1/4	31S6CFL-1/4	41GCFL-1/4	41S6CFL-1/4	48S6	49S6
Support Core, Required for Liquid Filtration	SS-100-12	SS-100-12	SS-100-25	SS-100-25	Included	----
Filter Cartridges	100-12-□	100-12-□	100-25-□	100-25-□	050-11-□	100-185-□
Use only these Filter types	XE, H, Q, M	XE, H, Q, M	XE, H, Q, M	XE, H, Q, M	XE, H, Q, M	XE, H, Q

Horizontal mounting minimizes space requirement on panel

All connections are made to the head eliminating the need to break the lines for filter changeouts

The only filter available that is mounted at an angle to ensure complete removal of all liquids

Includes cadmium plated steel mounting bracket



Model 47S6

Model 47S6

The Model 47S6 is designed to filter particulates and liquids from a gas sample, protecting on-line process analyzers from contamination. This unique design allows the filter to be mounted horizontally which minimizes the amount of space taken up on the panel.

It is also angled at 10° which ensures all collected liquids drain back to the drain port and not carried downstream to the analyzer. The drain port is drilled and tapped at an opposing angle eliminating the need to bend tubing.

Additionally, all connections (including the drain connection) are made to the head which eliminates the need to break the lines for filter changeouts. This is an ideal filter for those applications requiring high efficiency filtration with the need for convenient filter changes on crowded panels.

Principal Specifications

Model	47S6
Inlet and Outlet Ports	1/4" NPT
Drain Port	1/4" NPT
Materials of Construction	316 SS (2)
Seals	Viton
Maximum Temperature	400°F (204°C)
Maximum Pressure	1500 psig (1)
Shipping Weight	1lb. (0.4 kg)
Dimensions	1.5"D X 3.7"L (4cm X 9cm)

Ordering Information

Filter Housing Model	47S6
Filter Cartridges	050-11-□
Use only these filter types	Q, H
Support Core required for liquid filtration	Included

Notes:

- 1 1500 psig @ 200°F consult factory for pressure ratings at elevated temperatures.
- 2 Constructed of materials which comply with NACE Specification MR-01-75. Request certificate of compliance.



Coalescing Filtration: Separating Liquids From Gases

Microfibre Filter Cartridges efficiently separate suspended liquids from gases. The micro fibers capture the fine liquid droplets suspended in the gas and cause the droplets to run together to form large drops within the depth of the filter cartridge. The large drops, forced by the gas, flow to the downstream surface of the filter cartridge, from which the liquid drains by gravity. This process is called "coalescing". Since the coalesced liquid drains from the cartridge at the same rate that liquid droplets enter the cartridge, the cartridge has an unlimited life when coalescing liquids from relatively clean gases, and the filters operate at their initial retention efficiency even when wet with liquid (see Figure 1). Note that the flow direction is inside-to-outside, to permit the liquid to drip from the outside of the filter to the housing drain.

Since the coalesced liquid drips from the downstream surface of the filter cartridge in the presence of filtered gas, it is important to avoid carryover, or entrainment, of liquid droplets by the gas leaving the filter housing. The possibility of entraining coalesced liquid is minimized by using an X-Type filter cartridge. The X-Type filter cartridges are constructed of two layers, an inner high-efficiency coalescing layer and an outer layer of coarse glass fibers. The coarse, rapidly-draining outer layer ensures that the liquid drips continuously from the bottom of the filter cartridge and minimizes the chance of liquid carryover. (The small internal volume of some filter housings does not permit use of the thick-wall X-Type cartridges, and therefore Q-Type cartridges must be used.) Re-entrainment of coalesced liquid is also avoided by ensuring that the gas flow rate through the housing is safely below the maximum shown in the flow charts on page 31. For most requirements for removing liquid from gas samples, Grade DX or DQ filter cartridges should be used.

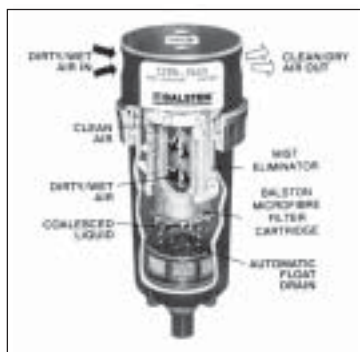

Figure 1
Balston Compressed Air Filter

Draining Collected Liquid

If liquid is carried into the filter in slugs rather than dispersed as droplets in the gas, a filter which is properly sized for steady-state conditions can be flooded and permit liquid carryover. If slugging of liquid is expected, a filter with a relatively large bowl should be selected to provide adequate liquid holding capacity and provisions should be made to drain the liquid automatically from the bowl of the housing as fast as it accumulates. An automatic float drain can be used if the pressure is in the 10-400 psig range. Above 400 psig, the possibilities are: a constant bleed drain, a valve with automatic timed actuator (supplied by customer), or an external reservoir with manual valves (see Figure 2). The external reservoir can be constructed of pipe or tubing with sufficient volume to hold all the liquid which is expected to be collected during any period of unattended operation.

If the filter is under vacuum, the external reservoir is a practical method of collecting coalesced liquid for manual draining from time to time. If an external vacuum source, such as an aspirator, is available, the liquid may be drained continuously from the housing drain port.

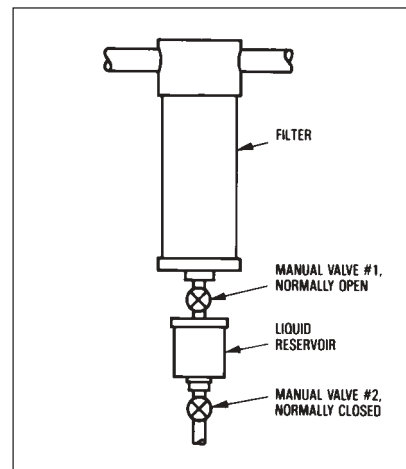

Figure 2
To drain liquid while filter is operating at pressure or vacuum conditions, close valve #1, and open valve #2

Coalescing Filtration: Separating Two Liquid Phases

In principle, Microfibre Filter Cartridges separate suspended droplets of a liquid which is immiscible in another liquid by the same process as they separate droplets of liquid from a gas. The liquid droplets suspended in the continuous liquid phase are trapped on the fibers and run together to form large drops, which are then forced through the filter to the downstream surface. The large drops separate from the continuous liquid phase by gravity difference, settling if heavier than the continuous phase and rising if lighter. The coalescing action of Balston® filters is effective with aqueous droplets suspended in oil or other hydrocarbons, and also with oil in water suspensions.

In practice, liquid-liquid separations are much more difficult than liquid-gas separations. The specific gravity difference between two liquids is always less than between a liquid and a gas, and therefore a longer phase separation time is needed. Either the filter housing must be oversized or the flow rate greatly reduced to avoid carryover of the coalesced phase. As a rule of thumb, flow rate for liquid-liquid separation should be no more than one-fifth the flow rate for solid-liquid separation shown in the chart on page 30. Even at low flow rates, if the specific gravity difference between the two liquids is less than 0.1 units (for example, if an oil suspended in water has a specific gravity between 0.9 and 1.1), the separation time for the coalesced phase may be impractically long. In that case, if there is only a small quantity of suspended liquid, the filter tube can be used until saturated with the suspended liquid and then changed.

Another practical problem with liquid-liquid separations is that small quantities of impurities can act as surface-active agents and interfere with the coalescing action. For that reason it is not possible to predict accurately the performance of a liquid-liquid coalescing filter, and each system must be tested on site. The general guidelines for the system to start testing are to use Grade DXE filter cartridges, and flow inside-to-outside at very low flow rates. If the suspended liquid is lighter than the continuous phase, the housing should be oriented so that the drain port is up. In general, Microfibre Filter Cartridges should be used for liquid-liquid coalescing in slipstream sampling applications only.

Membrane Separation of Sample Streams

A Coalescer Membrane Combination Filter is designed to remove entrained liquid and particulate in gas samples for a wide variety of applications, and to prevent contamination or damage to the analyzers and sample system components. Microscopic pores contained within the membrane permit molecules of gas or vapor to flow through easily, allowing the composition of the sample gas to remain unchanged. However, even the smallest liquid molecules remain trapped and are unable to flow through the membrane's small passages under normal operating conditions. This is due to the high surface tension which causes liquid molecules to bind tightly together to form a group of molecules, moving together, which is too large to fit through the pores of the membrane.

The membrane is extremely inert, and is recommended for most process liquid applications, with the exception of hydrofluoric acid. It is also recommended for use in systems designed for PPB, PPM, and "percent level" component concentrations, as a result of its very low absorption characteristics. The membrane is strong and durable, but also very soft and pliable. Typically located upstream from the analyzer or component it is protecting, the Coalescer Membrane Combination provides protection even if other sample system components fail.

Removing Gas Bubbles from Liquids

Microfibre Filter Cartridges readily remove suspended gas bubbles from liquid, eliminating the need for deaeration tanks, baffles, or other separation devices. Flow direction through the filter is outside-to-inside. The separated gas bubbles rise to the top of the housing and are vented through the drain port. If slipstream sampling is used, the separated bubbles are swept out of the housing with the bypassed liquid. Grade DXE or Grade DQ is a good choice for gas bubble separation.



Quantitative Measurement of Solids in Gas

Quantitative determination of solids in gas, often a requirement in stack gas or other exhaust gas sampling, is readily accomplished using a Balston® Model 30 filter housing. In the Model 30 housing, the filter cartridge is sealed in place by a stainless steel spring acting on a lightweight stainless retainer disc (Figure 3). The retainer disc is pressed firmly into the end of the filter cartridge. When the housing is disassembled, the filter cartridge and retainer disc may be easily removed as a unit. At the beginning of the run, a tare weight is obtained on the filter cartridge-retainer disc assembly. When the filter is in service, flow through the filter cartridge is inside-to-outside so that even large solid particles which fall off the filter cartridge are held in the cartridge-disc assembly. At the conclusion of the run with a known volume of gas, the cartridge-disc assembly is reweighed, and the increase in weight can be expressed as solids concentration in the gas. Grade DH Filter Cartridges are recommended for high temperature sampling (up to 900°F/482°C). If the sampling or oven-drying temperatures do not exceed 300°F (149°C), Grade DQ may be used.

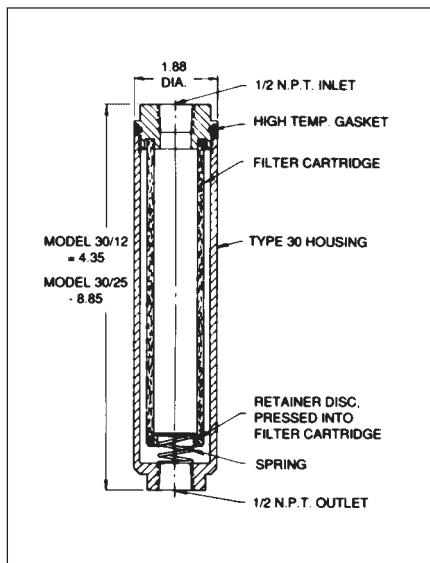

Figure 3

Filter cartridge and retainer disc of Model 30 housing may be weighed as a unit for quantitative determination of solids in gases.

Slipstream or Bypass Sampling

Instrument sample use rates are invariably quite low, yet it is essential to minimize lag time in the sample system. Since analyzers often are located some distance from the sampling point, samples are usually transported to the analyzer at a relatively high flow rate to minimize lag time. The sample is divided at the analyzer, with the analyzer using the portion it requires (usually a very small fraction of the total sample), and the balance recycled to the process, or vented.

If the sample filter is located in the low-flow line to the analyzer, it will have good life between filter element changes because the solids loading rate is very low; however, the filter must be carefully selected to avoid introducing unacceptable lag time. If the filter is located in the high-flow portion of the sample system, its effect on sample lag time can be relatively low, but the life between filter changes may be inconveniently short because the element is filtering a much greater volume of material than the analyzer is using.

Ideally, a filter should be located at the point where the low-flow stream is withdrawn to the analyzer (Figure 4). This arrangement permits the main volume of the filter to be swept continuously by the high flow rate stream, thus minimizing lag time; at the same time, only the low-flow stream to the analyzer is filtered, thus maximizing filter life.

A slipstream filter requires inlet and outlet ports at opposite ends of the filter element to allow the high flow rate of the by-passed material to sweep the surface of the filter element and the filter reservoir, and a third port connected to the low flow rate line to the analyzer, which allows filtered samples to be withdrawn from the filter reservoir.

The Model 95 housings, 31GCFL, 41GCFL, 48S6, 49S6, DFU 8822-11, and DFU 8833-11 are ideal designs for slipstream sampling, since the inlet and the bypass ports are located at opposite ends of the housing, and the bypass port is as large as the inlet port. Larger housings, such as the Model 33S6, Model 45S6, and Model 27/35, can also be used for slipstream sampling, but the relatively small size of the drain port may limit the slipstream rate in some applications.

If bubble removal from a liquid is a requirement, this function may be combined with slipstream filtration, since the recommended flow direction for bubble removal is outside-to-inside, and the separated bubbles will be swept out of the housing by the bypass stream. In this case, the liquid feed should enter at the bottom of the housing and the bypass liquid exit at the top of the housing.

Slipstream Sampling Plus Coalescing Filtration

A special problem arises in slipstream sampling if the filter is to coalesce and continuously drain suspended liquid from a gas stream or to coalesce liquid droplets from a liquid stream. As noted earlier (see page 32), the coalesced liquid is removed in the form of large drops from the downstream side of the filter. Therefore, the coalescing filter requires two outlet ports, one for the dry gas and one for the liquid drain. To combine coalescing and slipstream filtration, a filter housing would need four ports - two for inlet and bypass and two for filtered gas and coalesced liquid - which is not a practical design. Therefore, slipstreaming plus coalescing requires two stages of filtration (Figure 5). The second (coalescing) stage must be located in the sample line to the analyzer, and should be as small as possible to minimize lag time. If the quantity of suspended liquid is not large, an in-line Disposable Filter Unit (9933-05 or 9922-05) may be considered as a trap for the suspended liquid, to be replaced when saturated.

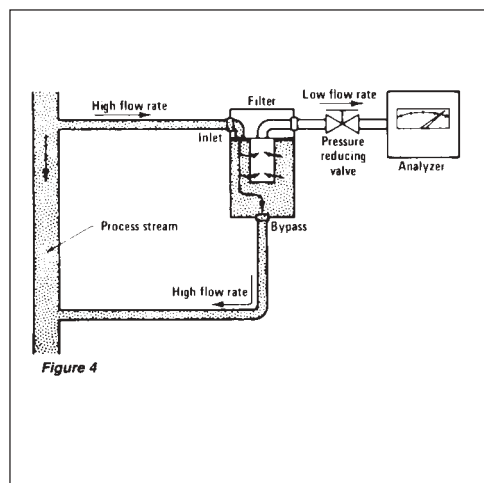

Figure 4
Slipstream or
bypass filtration

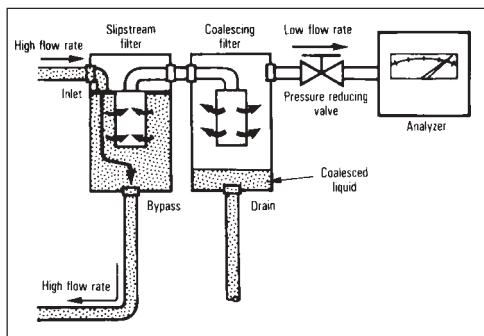

Figure 5
Slipstream Filtration
plus coalescing
filtration

Quantitative Measurement of Liquids in Gas

Quantitative determination of nonvolatile liquids suspended in a gas may be accomplished by a procedure similar to the solids determination (see page 33). In the case of liquids, the test is designed so that all the liquid entering the filter cartridge during the test period remains trapped on the fibers; i.e., the sample period is short enough that the filter cartridge does not become saturated and begin to drain liquid.

Any convenient filter housing may be used. The filter cartridge should be Grade BQ, to assure quantitative retention of aerosols, no matter what droplet size. With a known gas flow rate and test duration, the increase in weight of the filter cartridge will be a measure of the weight concentration of aerosol in the gas.

Considerable care must be taken to obtain a representative sample of aerosol in gas. If sampling from a large line, the sample probe should enter the pipe from above and if possible, extend into the pipe to avoid picking up liquid clinging to the wall of the pipe. There should be no valves, reducers, or sharp elbows in the sample line upstream from the filter.



Acid Plant Stack Gas

A frequently encountered sampling requirement is to analyze the gas composition in the exhaust from absorbers or scrubbers in acid manufacturing plants. The exhaust gas invariably contains droplets of dilute acid, which must be removed from the sample before it enters the analyzer. The recommendations are similar to those for natural gas sample filtration: Grade DQ or DXE filter tube, inside-to-outside flow, and two stages of filtration if slipstream sampling is required. Depending upon the composition of the suspended liquid, housings may be stainless steel, Teflon (Model 95T), Monel (Model 95M), or PVDF (DFU 8822-11).

Sampling Ambient Air or Other Atmospheric Pressure Gas

The filtration requirement for ambient air samplers is usually to remove solid particles or liquid droplets which could deposit on analyzer optical surfaces or cause other calibration problems. Grade DXE or DQ filter cartridges are recommended. For low flow rate personal samplers, the compact and lightweight DFU 9933-05-DQ is often used. For higher flow rates, the Model 90 filter holder with Grade DXE or DQ filters is recommended.

Ambient air sampling systems are often under negative pressure, induced by the sampling pump. If it is necessary to drain coalesced liquid from the system, the external reservoir is often the most convenient method (see Figure 2 on page 33).

Sampling Water

Most water analyzers are well protected against the damage or calibration drift caused by solid contamination if a 10 micron (LP Grade 30) filter cartridge is used. If long filter life is desired in a system with high solids loading (including most tap water, well water, and cooling water), a two stage LP cartridge system is recommended: LP Grade 10 followed by LP Grade 30.

Sampling Liquid Effluent Streams

Liquid effluent analyzers usually deal with aqueous streams having a high solids content. In addition, the analyzers are often located in remote areas of the plant and are infrequently serviced. Therefore, the sample filter system must have long life between filter cartridge changes, even in a high solids situation. The general recommendation for this requirement is a two stage filter system, LP Grade 10 filter cartridge followed by LP Grade 30 filter cartridge. The filters should be oversized as much as possible without causing excessive lag time. Plastic filter housings are usually a good choice.

Measurements of steam and condensate conductivity, specific ion concentrations, and feedwater additive concentrations are often required in high pressure boiler systems. In a continuous sampling system, the high pressure steam or condensate is cooled to below 100°F (38°C) and then the pressure is reduced to near atmospheric pressure for metering to the analyzers. Filtration is required upstream from the pressure reducing valves, to prevent pitting of the valve seats by suspended particles and to eliminate variations in flow rate to the analyzers.

A stainless steel filter housing with the appropriate pressure rating and Grade DXE or DQ filter cartridge is recommended. Since the analyzer system is often located some distance from the sampling point, slipstream filtration is usually required. Figure 9 shows a sampling system in operation at a nuclear steam generating facility.

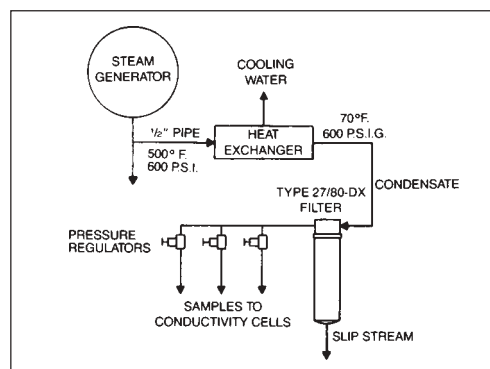

Figure 9

Model 27 filter with Grade DX filter cartridge protects pressure reducing valves in a steam condensate sampling system.

On-Line Process Analyzers

The variety of filtration requirements for on-line process analyzers precludes making general recommendations above for the required filtration functions. The filter housings most frequently used for process analyzer applications are the Model 95S6 and Model 91S6, which provide the corrosion resistance of Model 316 stainless steel (complies with NACE specification MR-01-75), a pressure rating of 5000 psig, have full slipstream sampling capability, and minimum internal volume.



Figure 6
Model 95S6, 316 stainless steel with 5,000 psig pressure rating, is the filter housing most frequently used in process analyzers

Natural Gas Analyzers

To protect gas composition analyzers from liquids and solids, Grade DXE or DQ filter tubes are recommended, with inside-out flow direction. If both slipstream sampling and coalescing are required, a two stage system must be used, as described on page 35.

The Model 85 (5000 psig rating) and Model 37 (4000 psig rating) housings comply with NACE specification MR-01-75. For lower pressure applications, any stainless steel housing of appropriate flow capacity may be used.



Figure 7
Model 85 (left) or Model 37/12 (right) are used for natural gas sample filtration when a housing larger than the Model 95S6 is required

Stack Gas Sampling

The Model 30 housing with Grade DH filter cartridge is used for quantitative determination of solids in stack gas, as described on page 34. The Model 30 may also be used as a beginning-of-the-line filter at stack gas temperature (up to 1000°F/538°C), to prevent solids from entering the gas sample line. Grade DH is used for this purpose. After the sample is cooled, a coalescing filter with Grade DXE tube is used to remove suspended liquids before the sample goes to the analyzer. Flow direction is inside-to-outside. Model 33G or 45G housings are often used in this application to permit a visual check on the liquid level in the filter housing. Since there often is a considerable amount of liquid present at this point, positive steps must be taken to drain the housing to ensure that liquid does not build up and carry downstream to the analyzer.

The coalescing filter should be located as close to the analyzer as possible to minimize the chance of condensation between the filter and the analyzer. Additional precautions which can be taken to avoid downstream condensation are to cool the sample below ambient temperature upstream from the coalescing filter, and to heat the line.

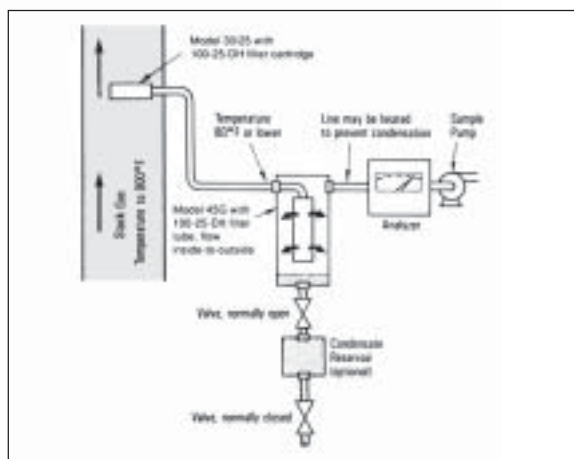

Figure 8
Stack gas sample lines usually require a high temperature solids filter at the sample point and a condensate separator immediately upstream from the analyzer



Application Notes

Application Notes

Balston Vacuum Pump Exhaust and Inlet Filters



Exhaust filters eliminate oil mist and smoke from vacuum pump exhaust

Prevent oil backstreaming

Prevent oil accumulation in ductwork

Protect vacuum pumps and reduce costly maintenance

Easy to install and maintain

Balston Vacuum Pump Exhaust and Inlet Filters

Balston Vacuum Pump Exhaust Filters remove 99.9% of 0.1 micron oil mist and smoke particles. Balston Grade 30 Vacuum Pump Inlet Filters remove 90% of all 0.1 micron particles and droplets. Balston Grade 102 Vacuum Pump Inlet Filters prevent oil backstreaming from the pump to the evacuated chamber, and protect the pump from damage by submicron particles (at relatively low concentrations).

All Balston filters are available for hazardous and non-hazardous applications, and offer superior chemical and solvent resistance. Balston Vacuum Pump Filters increase productivity by eliminating costly shutdown time and maintenance.

Eliminate 99.9% oil mist and smoke from vacuum pump exhaust

Prevent oil accumulation in ductwork

Recover expensive lubricating oils, and automatically return filtered oil to pump

Eliminate potential OSHA and EPA violations

Balston Vacuum Pump Exhaust Filters

Balston Vacuum Pump Exhaust Filters remove all visible oil mist and smoke from vacuum pump exhaust, even when it is saturated with oil. The high efficiency filter cartridge continuously drains the collected liquid, allowing the user to recover expensive lubricating fluid. Filters are available for pumps with flow ratings ranging from 3 to 200 cfm.

How To Select The Filter

For most applications, simply select the filter assembly which has a flow capacity equal to or greater than the vacuum pump exhaust flow output (see chart below). The Filter Assemblies are shipped with filter cartridges, pressure gage (20 cfm and larger), and final filter pad. Optional adaptors are available for KF and NW connections.



CV-0118



ACV-0135



ACV-0780

Filter Selection Chart (for hazardous/corrosive applications)

Max. Pump Flow Rate (CFM)	Recommended Filter Model Number
3	CV-0112-371H
9	CV-0118-371H
20	ACV-0135-371H
100	ACV-0735-371H
200	ACV-0780-371H

Principal Specifications					
Model	CV-0112-371H	CV-0118-371H	ACV-0135-371H	ACV-0735-371H	ACV-0780-371H
Port Size	1/2" NPT	3/4" NPT	1" NPT	2" NPT	2" NPT
Max. Flow Rate	3 CFM	9 CFM	20 CFM	100 CFM	200 CFM
Materials of Construction					
Head	---	---	304 SS	304 SS	304 SS
Bowl	304 SS	304 SS	304 SS	304 SS	304 SS
Internals	304 SS	304 SS	304 SS	304 SS	304 SS
Seals	None	None	Viton	Viton	Viton
Maximum Temperature	250°F (121°C)	250°F (121°C)	250°F (121°C)	250°F (121°C)	250°F (121°C)
Maximum Pressure	15 psig	15 psig	15 psig	15 psig	15 psig
Shipping Weight	0.5 lbs. (0.2 kg)	0.8 lbs. (0.4 kg)	9.5 lbs. (4.3 kg)	55 lbs. (25 kg)	71 lbs. (32 kg)
Dimensions	2.9"Dia. X 4.2"H (7cm X 11cm)	4.0"Dia. X 5.3"H (10cm X 13cm)	4.1"Dia. X 23"H (10cm X 58cm)	10"Dia. X 29"H (25cm X 74cm)	10"Dia. X 38"H (25cm X 96cm)

Ordering Information					
For assistance, call toll-free at 1-800-343-4048 8AM to 5PM Eastern Time					
Model	CV-0112-371H (1)	CV-0118-371H (1)	ACV-0135-371H	ACV-0735-371H	ACV-0780-371H
Number of Filter Cartridges Required	---	---	1	7	7
Replacement Filter Cartridges					
Box of 3	---	---	3/200-35-371H	---	---
Box of 7	---	---	---	7/200-35-371H	7/200-80-371H
Box of 10	---	---	200-35-371H	---	---
Number of Pressure Relief Retainers #20222	---	---	1	2	2
Optional Accessories:	#11015 Back Pressure Gage, Stainless Steel, 0-15 psi rating, 1/4" NPT fitting. Vacuum Pump-to-Filter Adaptors: Please refer to Page 20.				

Notes:

1 Filter cartridge is permanently sealed into housing. The entire unit is disposable. Pressure relief filter tube retainer not available in these models.



Eliminate 99.99% oil mist and smoke from vacuum pump exhaust

Prevent oil accumulation in ductwork

Recover expensive lubricating oils, and automatically return filtered oil to pump

Eliminate potential OSHA and EPA violations

Balston Vacuum Pump Exhaust Filters

Balston Vacuum Pump Exhaust Filters remove all visible oil mist and smoke from vacuum pump exhaust, even when it is saturated with oil. The high efficiency filter cartridge continuously drains the collected liquid, allowing the user to recover expensive lubricating fluid. Filters are available for pumps with flow ratings ranging from 3 to 850 cfm.

How To Select The Filter

For most applications, simply select the filter assembly which has a flow capacity equal to or greater than the vacuum pump exhaust flow output (see chart below). The filter assemblies are shipped with filter cartridges, pressure gage (20 cfm and larger), and final filter pad. Optional adaptors are available for KF and NW connections (see Pg 19).



Model 9955-12



Model 18/18



Model AR-0316



Model AR-0780



Model AR-3080

Filter Selection Chart (for non-hazardous/non-corrosive applications)	
Max. Pump Flow Rate (CFM)	Recommended Filter Model Number
3	9955-12-371H, 9956-12-371H
9	18/18-371H
20	AR-0316-371H
43	AR-0335-371H
100	AR-0735-371H
200	AR-0780-371H
300	AR-1280-371H
450	AR-1680-371H
850	AR-3080-371H

Note: The suffix "30" indicates the filter cartridge grade. For removal of high concentrations of solids and liquids use "30" suffix. For prevention of oil backstreaming and filtration of low solids concentrations, use "102" suffix.

Principal Specifications

Model	Port Size	Max. Flow Rate	Materials of Construction				Max. Temp.	Max. Press.	Shipping Wt.	Dimensions
			Head	Bowl	Internals	Seals				
9955-12-371H	1/2" NPT	3 CFM	---	Nylon	Nylon	None	250°F (121°C)	15 PSIG	.25 lbs (0.1 kg)	2"Dia. X 3.7"H
9956-12-371H	KF-16	3 CFM	---	Nylon	Nylon	None	250°F (121°C)	15 PSIG	.25 lbs (0.1 kg)	2"Dia. X 3.7"H
18/18-371H	3/4" NPT	9 CFM	---	Steel	Steel	Viton	400°F (204°C)	15 PSIG	.8 lbs (0.4 kg)	3.5"Dia. X 5.4"H
AR-0316-371H	1" NPT	20 CFM	Steel	Steel	Anod. Alum.	Buna/Neo	400°F (204°C)	15 PSIG	8 lbs (4 kg)	7.4"Dia. X 8.8"H
AR-0335-371H	1 1/2" NPT	43 CFM	Steel	Steel	Anod. Alum.	Buna/Neo	400°F (204°C)	15 PSIG	11 lbs (5 kg)	7.4"Dia. X 15"H
AR-0735-371H	3" NPT	100 CFM	Steel	Steel	Anod. Alum.	Buna/Neo	400°F (204°C)	15 PSIG	17 lbs (8 kg)	10"Dia. X 18"H
AR-0780-371H	3" NPT	200 CFM	Steel	Steel	Anod. Alum.	Buna/Neo	400°F (204°C)	15 PSIG	23 lbs (10 kg)	10"Dia. X 28"H
AR-1280-371H	4" Flg. (1)	300 CFM	Steel	Steel	Anod. Alum.	Buna/Neo	400°F (204°C)	15 PSIG	90 lbs (41 kg)	19"Dia. X 43"H (5)
AR-1680-371H	4" Flg. (1)	450 CFM	Steel	Steel	Anod. Alum.	Buna/Neo	400°F (204°C)	15 PSIG	100 lbs (45 kg)	19"Dia. X 43"H (5)
AR-3080-371H	6" Flg. (1)	850 CFM	Steel	Steel	Anod. Alum.	Buna/Neo	400°F (204°C)	15 PSIG	150 lbs (68kg)	23"Dia. X 43"H (5)

Ordering Information

For assistance, call toll-free at 1-800-343-4048 8AM to 5PM Eastern Time

Model	No. of Filter Cartridges Required	Replacement Filter Cartridges		Box of 10	Cover (2) (Optional)	No. Pressure Relief Retainers #20222
		Box of 3	Box of 7			
9955-12-371H (3)	1	3/9955-12-371H	---	9955-12-371H	---	(4)
9956-12-371H (3)	1	3/9956-12-371H	---	9956-12-371H	---	(4)
18/18-371H	1	---	---	---	---	(4)
AR-0316-371H	3	3/200-16-371H	---	---	19158	1
AR-0335-371H	3	3/200-35-371H	---	---	19158	1
AR-0735-371H	7	---	7/200-35-371H	---	19206	2
AR-0780-371H	7	---	7/200-80-371H	---	19206	2
AR-1280-371H	12	---	---	200-80-371H	Included	4
AR-1680-371H	16	---	---	200-80-371H	Included	4
AR-3080-371H	30	---	---	200-80-371H	Included	6
Optional Accessories:	#20222 Pressure Relief Filter Cartridge Retainer, 4-7 psig. #20222 Pressure Relief Filter Cartridge Retainer, 2-5 psi. #20217 Pressure Relief Valve, 3-7 psig, 1/4" NPT male fitting. #11010 Pressure Gage, 0-15 psig, 1/4" male fitting (incl. on Type AR Filter Assemblies) Vacuum pump-to-filter adaptors: refer to data sheet PK-3-6. #19291 Stand for AR-1680-371H, #19290 Stand for AR-3080-371H. #19202 Weather Cap for AR-0735-371H, AR-0780-371H.					

Notes:

- 1 ANSI 150 lb. hole pattern.
- 2 Cover does not provide leak tight seal.
- 3 Filter cartridge is permanently sealed into housing. The entire unit is disposable.
- 4 Pressure relief filter tube retainer not available in these models.
- 5 Height dimension represents filter housing alone. When assembled with a stand, the height is adjustable from 46" to 56" (117cm to 142 cm).



**Protect vacuum pumps from damage
by solids and liquids**

**Prevent loss of valuable or hazardous
materials**

Prevent oil backstreaming



CF-0118

**Model CF-0112 and CF-0118
for Vacuum Service to 10⁻⁶ Torr**

Stainless steel housings with welded KF flange inlet and outlet ports and no drain ports. They are designed to be used primarily with the Grade 102 adsorbent cartridges for prevention of oil backstreaming (see cartridge selection chart below). They may also be used with Grade 30 cartridges for removal of high concentrations of solids, but the absence of drain ports precludes the use of CF housings for liquid removal in vacuum applications.

Filter Selection Chart

Grade 30 Cartridges	For removal of relatively high concentrations of solids
Efficiency:	90% at 0.1 micron
Loss in pumping speed:	9% at maximum flow rate
Materials of construction:	Polypropylene cartridge, EPR seals
Maximum temperature:	180°F (82°C)
Grade 102 Cartridges	For prevention of oil backstreaming and filtration of relatively low concentrations of solids
Efficiency for preventing oil backstreaming:	99.99%
Life:	Approximately 1000 hours at 10 microns vacuum
Efficiency for solids filtration:	99.99% at 0.1 micron
Materials of construction:	Molecular Sieve Type 4A adsorbent, EPR seals
Maximum temperature:	100°F (38°C)

Principal Specifications		
Model	CF-0112	CF-0118
Recommended Vacuum Service	10 ⁻⁶ Torr	10 ⁻⁶ Torr
Max. Flow Rating of Vacuum Pump	3 CFM	9 CFM
Inlet and Outlet Ports	KF-25	KF-25
Materials of Construction		
Head	304 SS	304 SS
Bowl	304 SS	304 SS
Internals	304 SS	304 SS
Seals	None	None
Maximum Temperature	180°F (82°C) (1)	180°F (82°C) (1)
Shipping Weight	0.5 lbs. (0.2 kg)	0.8 lbs. (0.4 kg)
Dimensions	2.9"W X 4.4"L (7cm X 11cm)	3.9"W X 5.9"L (10cm X 15cm)

Notes:

- 1 Maximum temperature grade 102 Cartridge is 100°F (38°F).
- 2 Filter Cartridge is permanently sealed into housing. The entire unit is disposable.

Ordering Information		
For assistance, call toll-free at 1-800-343-4048 8AM to 5PM Eastern Time		
Assembly with Grade 30 Particulate Filter	Assembly with Grade 102 Backstreaming Filter	Number of Filter Cartridges Required (2)
CF-0112-30	CF-0112-102	N/A
CF-0118-30	CF-0118-102	N/A



Protect vacuum pumps from damage
by solids and liquids

Prevent loss of valuable or hazardous
materials

Prevent oil backstreaming



18/18-30

**Models CV-0112-30 and CV-0118-30
for hazardous/corrosive applications
and low flow applications**

Stainless steel housings with NPT inlet, outlet and drain
ports. Used only with Grade 30 filter cartridges.

**Model 18/18-30 for non-hazardous/non-
corrosive applications and higher flow
applications**

Steel housing with NPT inlet, outlet and drain ports.
Used only with Grade 30 filter cartridges.

Filter Selection Chart

Grade 30 Cartridges	For removal of relatively high concentrations of solids and liquids
Efficiency:	90% at 0.1 micron
Loss in pumping speed:	9% at maximum flow rate
Materials of construction:	Polypropylene cartridge, EPR seals
Maximum temperature:	180°F (82°C)

Principal Specifications

Model	CV-0112-30	CV-0118-30	18/18-30
Recommended Vacuum Service	2 Torr	2 Torr	2 Torr
Max. Flow Rating of Vacuum Pump	3 CFM	9 CFM	9 CFM (1)
Inlet and Outlet Ports	1/2" NPT	3/4" NPT	3/4" NPT
Drain Port (2)	1/8" NPT	1/8" NPT	1/8" NPT
Materials of Construction			
Head	304 SS	304 SS	Steel
Bowl	304 SS	304 SS	Steel
Internals	304 SS	304 SS	Steel
Seals	None	None	None
Maximum Temperature	180°F (82°C)	180°F (82°C)	180°F (82°C)
Shipping Weight	0.5 lbs. (0.2 kg)	0.8 lbs. (0.4 kg)	2 lbs. (1 kg)
Dimensions	2.9"W X 4.4"L (7cm X 11cm)	3.9"W X 5.9"L (10cm X 15cm)	3.8"W X 5.4"L (10cm X 14cm)

Ordering Information

For assistance, call toll-free at 1-800-343-4048 8AM to 5PM Eastern Time

Assembly with Grade 30 Particulate Filter	Number of Filter Cartridges Required	Box of 3
CV-0112-30	(3)	---
CV-0118-30	(3)	---
18/18-30	(3)	---

Notes:

- 1 For higher flow capacity inlet filters, please consult factory.
- 2 Drain port must be downward for liquid removal.
- 3 Filter cartridge is permanently sealed into housing. The entire unit is disposable.



Pump Model No.	Pump Rating CFM (Free Air)	Pump Exhaust (NPT Female Unless Otherwise Noted)	Recommended Balston Filter Non-Hazardous Non-Corrosive Applications	Balston Anodized Aluminum Pump-To-Filter Adaptor (1)	Recommended Balston Filter Hazardous and Corrosive Applications	Balston Stainless Steel Pump-To-Filter Adaptor (1)
Alcatel Pumps						
ZM/ZT 1004A/AC	3.2	NW 25	18/18	14175	CV-0112	14182
ZM/ZT 1012A	11	NW 25	AR-0316	14173	ACV-0135	14177
ZM/ZT 1030	17	1" OD Tube	AR-0316		ACV-0135	
ZM/ZT 1033	27	NW 40	AR-0335	14174		
ZT 1060	30	1.63" OD Tube	AR-0335			
ZT 1063	50	NW 40	AR-0735	14174 (2)	ACV-0735	14178 (3)
ZT 1200A	150	1.63" OD Tube	AR-0780		ACV-0780	
ZM/ZT 2004A	3.2	NW 25	18/18	14173	CV-0112	14182
ZM/ZT 2007	7	NW 25	18/18	14173	CV-0118	14182
ZM/ZT 2008A/AC	7	NW 25	18/18	14173	CV-0118	14182
ZM/ZT 2012A/AC/H	11	NW 25	AR-0316	14173	ACV-0135	14177
UM/UT 2020	15.9	NW 25	AR-0316	14173	ACV-0135	14177
ZM/ZT 2030/H	17	1" OD Tube	AR-0316		ACV-0135	
ZM/ZT 2033/C	27	NW 40	AR-0335	14174		
ZT 2060/H/HUS	30	1.63" OD Tube	AR-0335			
ZT 2063/C	50	NW 40	AR-0735	14174 (2)	ACV-0735	14178 (3)
ZT 2100A/AC	90	NW 50	AR-0735		ACV-0735	14179 (3)
Balzers Pumps						
UNO/DUO 1.5A	1.0	KF10	9955-12		CV-0112	
UNO/DUO 004A/B	2.7	KF25	9955-12	14175	CV-0112	14182
UNO/DUO 008A/B	5.2	KF25	18/18	14173	CV-0118	14182
UNO/DUO 012A	8.2	KF25	18/18	14173	CV-0118	14182
UNO/DUO 016B	10.6	KF25	AR-0316	14173	ACV-0135	14177
UNO/DUO 030A	19.7	KF40	AR-0316	14174	ACV-0135	14178 (5)
UNO/DUO 060A	39.3	KF40	AR-0335	14174		
UNO/DUO 250A	157	ISO 100	AR-0780		ACV-0780	
UNO 100	56	32mm OD Tube (4)	AR-0735		ACV-0735	
DUO 100	57	32mm OD Tube (4)	AR-0735		ACV-0735	
UNO/DUO 120A	75.3	ISO 63	AR-0735		ACV-0735	
UNO 170	91.2	32mm OD Tube (4)	AR-0735		ACV-0735	
DUO 170	100	32mm OD Tube (4)	AR-0735		ACV-0735	
BA 251	158.9	ISO 63	AR-0780		ACV-0780	
BA 501	320.7	ISO 100	AR-1680		ACV-0780 (6)	

Notes:

- 1 If no part number is listed, adaptor is not supplied by Parker. In most cases, customer can assemble adaptor from standard pipe fittings. Refer to pages 19-20.
- 2 Requires 3" Male x 1 1/2" Female reducing bushing supplied by customer.
- 3 Requires 2" Male x 1 1/2" Female reducing bushing supplied by customer.
- 4 Exhaust port is horizontal. Customer should provide elbow so that filter is mounted vertically.
- 5 Requires 1" Male x 1 1/2" Female bushing supplied by customer.
- 6 Multiple filters piped in parallel are required.

Pump Model No.	Pump Rating CFM (Free Air)	Pump Exhaust (NPT Female Unless Otherwise Noted)	Recommended Balston Filter Non-Hazardous Non-Corrosive Applications	Balston Anodized Aluminum Pump-To-Filter Adaptor (1)	Recommended Balston Filter Hazardous and Corrosive Applications	Balston Stainless Steel Pump-To-Filter Adaptor (1)
Beach-Russ Pumps						
SS 1	6	3/4"	18/18		CV-0118	
SS 1 1/2	9	3/4"	18/18		CV-0118	
SS 2	15	3/4"	AR-0316		ACV-0135	
SS 3	28	1"	AR-0335			
SS 4	45	1 1/4"	AR-0735		ACV-0735	
SS 5	60	1 1/2"	AR-0735		ACV-0735	
RP/RV 6	8.5	1/2"	18/18		CV-0118	
SS 6	75	1 1/2"	AR-0735		ACV-0735	
SS 7	110	2"	AR-0780		ACV-0780	
SS 8	150	2 1/2"	AR-0780		ACV-0780	
SS 9	225	4"	AR-1280		ACV-0780 (2)	
SS 10	375	6"	AR-1680		ACV-0780 (2)	
RP/RV 12	18	3/4"	AR-0316		ACV-0135	
RP 15	30	1 1/2"	AR-0335			
RP 15-6	30	1"	AR-0335			
RP 30	50	1 1/2"	AR-0735		ACV-0735	
RP 30-6	50	1"	AR-0735		ACV-0735	
RP 50/50-6	80	2"	AR-0735		ACV-0735	
RP 135/135-12	140	3"	AR-0780		ACV-0780	
RP-150/150-12	175	3"	AR-0780		ACV-0780	
RP 250	310	5"	AR-1280		ACV-0780 (2)	
RP 250-12	310	4"	AR-1280		ACV-0780 (2)	
RP 325	375	5"	AR-1680		ACV-0780 (2)	
RP 325-12	375	4"	AR-1680		ACV-0780 (2)	
RP 375	500	6"	AR-3080		ACV-0780 (2)	
RP 375-50	500	4"	AR-3080		ACV-0780 (2)	
RP 750	900	8"	AR-1680 (2)		ACV-0780 (2)	
RP 750-50	900	5"	AR-1680 (2)		ACV-0780 (2)	
RP 1000	1100	8"	AR-3080 (2)		ACV-0780 (2)	
RP 1000-50	1100	5"	AR-3080 (2)		ACV-0780 (2)	
Busch Pumps						
002-192	1.4	KF-16	9956-12		CV-0112	14181
004-192	2.8	KF-16	9956-12		CV-0112	14181
008-192	5.6	KF-16	18/18	14172	CV-0118	14181 (4)
010-112/118	6	3/4"	18/18		CV-0118	
016-192	11.2	KF-16	AR-0316	14180	ACV-0135	14176
016-112/118	8	3/4" (3)	18/18		CV-0118	
021-336/338	15	3/4" (3)	AR-0316		ACV-0135	
025-132/138	20	1 1/4" (3)	AR-0316		ACV-0135	
040-132/138	28	1 1/4" (3)	AR-0335			
063-132/138	41	1 1/4" (3)	AR-0335			
110-132/138	63	1 1/4" (3)	AR-0735		ACV-0735	
160-112/118/132/138	117	2" (3)	AR-0780		ACV-0780	
216-002	125	2"	AR-0780		ACV-0780	
225-002	200	2"	AR-0780		ACV-0780	
240-002	300	2"	AR-1280		ACV-0780 (2)	
250-112/118/132/138	174	2" (3)	AR-0780		ACV-0780	
263-002	500	2"	AR-3080		ACV-0780 (2)	
400-212/218	300	2"	AR-1280		ACV-0780 (2)	
630-212/218	430	3" (3)	AR-1680		ACV-0780 (2)	
1000-212/228	650	6" (3)	AR-3080		ACV-0780 (2)	
1600-212/228	1100	6" (3)	AR-3080 (2)		ACV-0780 (2)	
429	125	2"	AR-0780		ACV-0780	
433	200	2"	AR-0780		ACV-0780	
437	310	2"	AR-1280		ACV-0780 (2)	
441	580	2"	AR-3080		ACV-0780 (2)	
445	780	6" (3)	AR-3080		ACV-0780 (2)	

Notes:

- 1 If no part number is listed, adaptor is not supplied by Parker. In most cases, customer can assemble adaptor from standard pipe fittings. Refer to pages 19-20.
- 2 Multiple filters piped in parallel are required.
- 3 Requires flange to NPT adaptor from pump manufacturer.
- 4 Requires 3/4" Male x 1/2" Female reducing bushing supplied by customer.

Pump Model No.	Pump Rating CFM (Free Air)	Pump Exhaust (NPT Female Unless Otherwise Noted)	Recommended Balston Filter Non-Hazardous Non-Corrosive Applications	Balston Anodized Aluminum Pump-To-Filter Adaptor (1)	Recommended Balston Filter Hazardous and Corrosive Applications	Balston Stainless Steel Pump-To-Filter Adaptor (1)
Central Scientific Pumps (Cenco, Boekel, HYVAC)						
HYVAC 1 (91105)	0.35	3/8"	9955-12		CV-0112	
HYVAC 2 (91305/8)	0.88	1/2"	9955-12		CV-0112	
HYVAC 4 (91482)	1.70	1/2"	9955-12		CV-0112	
HYVAC 7 (91506, 91502)	2.79	1/2"	9955-12		CV-0112	
HYVAC 7S (91138)	2.79	1/2"	9955-12		CV-0112	
HYVAC 14 (91705)	5.6	3/4"	18/18		CV-0118	
HYVAC 14S (91140)	5.6	3/4"	18/18		CV-0118	
HYVAC 28 (91905)	10.6	1 1/2"	AR-0316		ACV-0135	
HYVAC 28S (91142)	10.6	1 1/2"	AR-0316		ACV-0135	
HYVAC 45 (91955)	17.7	1 1/2"	AR-0316		ACV-0135	
HYVAC 150 (91957)	53	3"	AR-0735		ACV-0735	
HYVAC 300 (91960)	106	3"	AR-0780		ACV-0780	
MEGAVAC (92003)	2.0	1/2"	9955-12		CV-0112	
PRESSOVAC (90510/15/16)	1.23	3.8" OD Tube	9955-12		CV-0112	
DIRECT DRIVE (90703)	1.9	3/8"	9955-12		CV-0112	
DIRECT DRIVE (90700)	1.06	3/8"	9955-12		CV-0112	
Edwards High Vacuum Pumps						
SPEEDIVAC 2	1.9	3/8 BSPT	9955-12	14157	CV-0112	
E2M1	1.3	3/8 BSPT	9955-12	14157	CV-0112	
E2M2	2	3/4 BSPT	9955-12	14158	CV-0112	
E1/E2M5	4	3/4 BSPT	18/18	14159	CV-0118	
EDM6	5	1/2"	18/18		CV-0118	
E1/E2M8	6.7	3/4 BSPT	18/18	14159	CV-0118	
EDM12	10.3	1/2"	AR-0316		ACV-0135	
E1/E2M18	14.7	3/4"	AR-0316		ACV-0135	
EDM20	14.5	1/2"	AR-0316		ACV-0135	
E2M30	30	KF25	AR-0335	14183		
E1/E2M40	30	KF25	AR-0335	14183		
ED/ES 50	3.5	1/4"	18/18		CV-0118	
ED/ES65	2.3	1/4" (2)	9955-12		CV-0112	
E1/E2M80	57	KF25	AR-0735	14183 (4)	ACV-0735	14177 (4)
ED/ES100	3.5	1/4" (2)	18/18		CV-0118	
E1/E2M175	125	1 1/2"	AR-0780		ACV-0780	
ED/ES200	6.7	3/8" (2)	18/18		CV-0118	
E1/E2M275	145	1 1/2"	AR-0780		ACV-0780	
ES330	11.8	3/8" (2)	AR-0316		ACV-0135	
ISC 450	19.6	1/2"	AR-0316		ACV-0135	
ED 500	17.7	1/2"	AR-0316		ACV-0135	
ED660	23.3	1/2" (2)	AR-0335			
ISC 900	39.2	3/4"	AR-0335			
ES2000	71	1 1/2"	AR-0735		ACV-0735	
ES4000	145	1 1/2"	AR-0780		ACV-0780	
ES7500	275	2 1/2"	AR-1280		ACV-0780 (3)	
RV3	2.7	3/4"	9955-12	(4)	CV-0112	(4)
RV5	4.1	NW25	18/18	14173	CV-0118	14182
RV8	6.9	NW25	18/18	14173	CV-0118	14182
RV12	10.0	NW25	AR-0316	14173	ACV-0135	14177

Notes:

- 1 If no part number is listed, adaptor is not supplied by Parker. In most cases, customer can assemble adaptor from standard pipe fittings. Refer to pages 19-20.
- 2 Exhaust port is horizontal. Customer should provide elbow so that filter is mounted vertically.
- 3 Multiple filters piped in parallel are required.
- 4 Reducing bushing required. Customer to provide.

Pump Model No.	Pump Rating CFM (Free Air)	Pump Exhaust (NPT Female Unless Otherwise Noted)	Recommended Balston Filter Non-Hazardous Non-Corrosive Applications	Balston Anodized Aluminum Pump-To-Filter Adaptor (1)	Recommended Balston Filter Hazardous and Corrosive Applications	Balston Stainless Steel Pump-To-Filter Adaptor (1)
Gast Pumps						
0211	1.1	1/4"	9955-12		CV-0112	
0240	1.9	1/4"	9955-12		CV-0112	
0322	2.5	1/4"	9955-12		CV-0112	
0440	4.0	1/4"	18/18		CV-0118	
0465	4.0	3/8"	18/18		CV-0118	
0522	4.0	1/4"	18/18		CV-0118	
0740	5.9	3/8"	18/18		CV-0118	
0765	5.9	3/8"	18/18		CV-0118	
0822	7.2	3/8"	18/18		CV-0118	
1022	10.0	3/8"	AR-0316		ACV-0135	
1065	8.3	1/2"	18/18		CV-0118	
1550	11.5	1/2"	AR-0316		ACV-0135	
2065	17.0	3/4"	AR-0316		ACV-0135	
2067	17.0	3/4"	AR-0316		ACV-0135	
2565	21.0	3/4"	AR-0335			
3040	31.0	1"	AR-0335			
4565	48.0	3/4"	AR-0735		ACV-0735	
5565	55.0	1"	AR-0735		ACV-0735	
4BA-1-G482X	1.8	1/2"	9955-12		CV-0112	
4AB-1-G482X	1.8	1/2"	9955-12		CV-0112	
4BA-1-G492X	1.8	1/2"	9955-12		CV-0112	
4BA-1-G499	1.8	1/2"	9955-12		CV-0112	
4BA-1-G511X	1.8	1/2"	9955-12		CV-0112	
4BA-1-G538X	1.8	1/2"	9955-12		CV-0112	
5BA-1-G482X	3.5	1/2"	18/18		CV-0118	
5AB-1-G482X	3.5	1/2"	18/18		CV-0118	
5BB-1-G482X	3.5	1/2"	18/18		CV-0118	
6BA-1-G535X	7.0	1"	18/18		ACV-0135	
6AB-1-G504X	7.0	1"	18/18		ACV-0135	
7BA-1-G506X	10.6	1"	R-0316		ACV-0135	
7AB-1-G506X	10.6	1"	R-0316		ACV-0135	
8BA-1-G506X	14.1	1 1/4"	R-0316		ACV-0135	
8AB-G506X	14.1	1 1/4"	R-0316		ACV-0135	
Hitachi Pumps						
SVF 10F	3.6	M24 x 1	18/18	14168	CV-0118	
SVR 16F	5.7	M24 x 1	18/18	14168	CV-0118	
100 VPS	3.6	M24 x 1	18/18	14168	CV-0118	
160 VPD/VPS	5.7	M24 x 1	18/18	14168	CV-0118	
16 VP	5.7	M24 x 1	18/18	14168	CV-0118	
3 VPC	1.8	M14 x 1	9955-12		CV-0112	
4 VPC	3.5	M14 x 1	18/18		CV-0118	
Ingersoll-Rand Pumps						
AV/AVX2	2.7	3/8"	9955-12		CV-0112	
BV/BVX2	5.4	3/8"	18/18		CV-0118	
V23A/V23AX7	9	3/4"	18/18		CV-0118	
V235/V235X1	18	1"	AR-0316		ACV-0135	
V244/V244X2	32	1 1/4"	AR-0335			
V255/V255X3	60	1 1/2"	AR-0735		ACV-0735	
V255X5	60	1 1/2"	AR-0735		ACV-0735	
7V/7VX5	99	1 1/2"	AR-0735		ACV-0735	
15V/15VX7	133	2"	AR-0780		ACV-0780	
20VX10	214	2 1/2"	AR-1280		ACV-0780 (2)	
20V/20VX15	294	2 1/2"	AR-1280		ACV-0780 (2)	

Notes:

1 If no part number is listed, adaptor is not supplied by Parker. In most cases, customer can assemble adaptor from standard pipe fittings. Refer to pages 19-20.

2 Multiple filters piped in parallel are required.

Pump Model No.	Pump Rating CFM (Free Air)	Pump Exhaust (NPT Female Unless Otherwise Noted)	Recommended Balston Filter Non-Hazardous Non-Corrosive Applications	Balston Anodized Aluminum Pump-To-Filter Adaptor (1)	Recommended Balston Filter Hazardous and Corrosive Applications	Balston Stainless Steel Pump-To-Filter Adaptor (1)
ITT Pneumotive (Leiman Brothers)						
B	10	3/4"	AR-0316		ACV-0135	
C	18	1"	AR-0316		ACV-0135	
29-3J	20	1"	AR-0316		ACV-0135	
195-2	20	3/4"	AR-0316		ACV-0135	
C-3	22	1"	AR-0335			
30-3	35	1"	AR-0335			
C-6	37	1 1/2"	AR-0335			
29-6J	50	1 1/2"	AR-0735		ACV-0735	
30-6	60	1 1/2"	AR-0735		ACV-0735	
100	112	1 1/2"	AR-0780		ACV-0780	
100J	125	1 1/2"	AR-0780		ACV-0780	
107/107J	200	3'	AR-0780		ACV-0780	
Kinney Pumps						
KC/KVS/KVC-2	2	3/4"	9955-12		CV-0112	
KC/KVC-3	3	3/4"	9955-12		CV-0112	
KC-5	5	3/4"	18/18		CV-0118	
KVC-6	5.8	3/4"	18/18		CV-0118	
KC-8	8	3/4"	AR-0316		ACV-0135	
KS-13	13	1 1/4"	AR-0316		ACV-0135	
TCS-14	14	3/4"	AR-0316		ACV-0135	
KC-15	15	1 1/4"	AR-0316		ACV-0135	
KS-15	15	1 1/4"	AR-0316		ACV-0135	
KTC-21	21	1"	AR-0335			
TCS-21	21	3/4"	AR-0335			
KD-30	33	1 1/4"	AR-0335			
TCS-35	30	1 1/4"	AR-0335	14174		
KD-50	52	1 1/4"	AR-0735		ACV-0735	
TCS-55	54	1 1/2"	AR-0735		ACV-0735	
KTC-60	60	1 1/2" (2)	AR-0735		ACV-0735	
KDH-65	69	1 1/2"	AR-0735		ACV-0735	
TCS-70	71	1 1/2"	AR-0735		ACV-0735	
KDH-80	83	1 1/2"	AR-0735		ACV-0735	
TCS-90	88	2"	AR-0735		ACV-0735	
KTC-112	107	2" (2)	AR-0780		ACV-0780	
KDH-130	134	2"	AR-0780		ACV-0780	
KDH-150	165	2"	AR-0780		ACV-0780	
KT-150	144	2" (2)	AR-0780		ACV-0780	
KTC-225	221	3" (2)	AR-1280		ACV-0780 (3)	
KT-300	296	3" (2)	AR-1280		ACV-0780 (3)	
KT-500	494	3" (2)	AR-3080		ACV-0780 (3)	
KT-850	778	4" Flange	AR-3080		ACV-0780 (3)	
Lammert Pumps						
10301	2	1/2"	9955-12		CV-0112	
10302	2	1/2"	9955-12		CV-0112	
10305/01131	5	3/4"	18/18		CV-0118	
10307/01133	7.5	1"	18/18		CV-0118	
10310/02131	10	1"	AR-0316		ACV-0135	
02133	15	3/4"	AR-0316		ACV-0135	
03131/03231	20	1 1/4"	AR-0316		ACV-0135	
04231/04131	30	1 1/4"	AR-0335			
03133/03233	30	1 1/4"	AR-0335			
04133/04233	50	1 1/4"	AR-0735		ACV-0735	
05131/05231	75	2"	AR-0735		ACV-0735	
06231/05133/05233	100	2"	AR-0735		ACV-0735	
07231	125	3"	AR-0780		ACV-0780	
06233/08231	150	3"	AR-0780		ACV-0780	
07233	200	3"	AR-0780		ACV-0780	
08233/09231	250	3"	AR-1280		ACV-0780 (3)	
09233	350	3"	AR-1680		ACV-0780 (3)	

Notes:

1 If no part number is listed, adaptor is not supplied by Parker. In most cases, customer can assemble adaptor from standard pipe fittings. Refer to pages 19-20.

2 Exhaust port is horizontal. Customer should provide elbow so that filter is mounted vertically.

3 Multiple filters piped in parallel are required.

Pump Model No.	Pump Rating CFM (Free Air)	Pump Exhaust (NPT Female Unless Otherwise Noted)	Recommended Balston Filter Non-Hazardous Non-Corrosive Applications	Balston Anodized Aluminum Pump-To-Filter Adaptor (1)	Recommended Balston Filter Hazardous and Corrosive Applications	Balston Stainless Steel Pump-To-Filter Adaptor (1)
Leybold Heraeus Pumps						
D/S 2A	2.2	KF 16	9956-12		CV-0112	14181
D/S 4A	4.5	KF 16	18/18	14172	CV-0118	14181 (3)
D/S 8A	7.0	KF 25	18/18	14173	CV-0118	14182
D 4B	3.4	KF 16	18/18	14172	CV-0118	14181 (3)
D 8B	6.9	KF 16	18/18	14172	CV-0118	14181 (3)
D/S 16A	14.1	KF 25	AR-0316	14173	ACV-0135	14177
D25	20	KF 25	AR-0316	14173	ACV-0135	14177
D/S 30A	26.8	KF 40	AR-0335	14178		
SV 40	30	1 1/4"	AR-0335			
DK 50	32	KF 50	AR-0335			
D/S 60A	36.7	KF 40	AR-0335	14178		
D 65	53	KF 40	AR-0735	14174 (4)	ACV-0735	14178 (2)
SV 65	45	1 1/4"	AR-0335		ACV-0335	
E 75	49	KF 50	AR-0735		ACV-0735	14179 (2)
D/S 90A	55	KF 40	AR-0735	14174 (4)	ACV-0735	14178 (2)
DK 100	65	KF 50	AR-0735		ACV-0735	14179 (2)
SV 100	70	2"	AR-0735		ACV-0735	
E 150	94	KF 50	AR-0735		ACV-0735	14179 (2)
SV 180	125	2"	AR-0780		ACV-0780	
DK 200	130	3" ASA Flange	AR-0780		ACV-0780	
E 250	162	3" ASA Flange	AR-0780		ACV-0780	
SV 280	200	2"	AR-0780		ACV-0780	
SV 500	318	3"	AR-1280		ACV-0780 (5)	
SV 580	339	3"	AR-1680		ACV-0780 (5)	
Marvac Pumps						
A-1	1.06	3/8"	9955-12		CV-0112	
A-2	1.06	3/8"	9955-12		CV-0112	
A-10	1.6	3/8"	9955-12		CV-0112	
A-20	1.6	3/8"	9955-12		CV-0112	
A-222	3.5	1/2"	18/18		CV-0118	
B-2	2.65	1/2"	9955-12		CV-0112	
B-3	5.5	3/4"	18/18		CV-0118	
B-6	20	1 1/4"	AR-0316		ACV-0135	
B-20	3.53	1/2"	18/18		CV-0118	
B-30	8.8	1"	18/18		CV-0118	
B-222	7	3/4"	18/18		CV-0118	
R-10	1.5	3/8"	9955-12		CV-0112	
R-20	1.5	3/8"	9955-12		CV-0112	
R-22	2.65	3/8"	9955-12		CV-0112	
R-55	5.5	3/8"	18/18		CV-0118	
Maxima Pumps (Fisher Scientific)						
D2A (01-057-2A)	2.2	KF 16	9956-12		CV-0112	14181
D4A (01-057-4A)	4.5	KF 16	18/18	14172	CV-0118	14181 (3)
D8A (01-057-8A)	7.0	KF 25	18/18	14173	CV-0118	14182
D16A (01-057-16A)	14.1	KF 25	AR-0316	14173	ACV-0135	14177
D30A (01-057-30A)	26.8	KF 40	AR-0335	14174		
D60A (01-057-60A)	36.7	KF 40	AR-0335	14174 (4)		
D90A (01-057-90A)	55	KF 40	AR-0735		ACV-0735	14178 (2)

Notes:

- 1 If no part number is listed, adaptor is not supplied by Parker. In most cases, customer can assemble adaptor from standard pipe fittings. Refer to pages 19-20.
- 2 Requires 2" Male x 1 1/2" Female reducing bushing supplied by customer.
- 3 Requires 3/4" Male x 1/2" Female reducing bushing supplied by customer.
- 4 Requires 3" Male x 1 1/2" Female reducing bushing supplied by customer.
- 5 Requires Multiple Filters piped in parallel.

Pump Model No.	Pump Rating CFM (Free Air)	Pump Exhaust (NPT Female Unless Otherwise Noted)	Recommended Balston Filter Non-Hazardous Non-Corrosive Applications	Balston Anodized Aluminum Pump-To-Filter Adaptor (1)	Recommended Balston Filter Hazardous and Corrosive Applications	Balston Stainless Steel Pump-To-Filter Adaptor (1)
Precision Scientific Pumps						
DD-20	0.7	3/4"	9955-12		CV-0112	
D-25	0.9	3/4"	9955-12		CV-0112	
S/PV-35	1.25	3/4"	9955-12		CV-0112	
DD-50	1.77	3/4"	9955-12		CV-0112	
D-75	2.7	3/4"	9955-12		CV-0112	
DD-90	3.2	3/4"	18/18		CV-0118	
DD-100	3.54	3/4"	18/18		CV-0118	
D-150	5.3	3/4"	18/18		CV-0118	
DD/DDC-195	7	3/4"	18/18		CV-0118	
S/D-300	10.6	1"	AR-0316		ACV-0135	
DD/DDC 310	11	3/4"	AR-0316		ACV-0135	
DD/DDC 475	17	3/4"	AR-0316		ACV-0135	
S/D-500	17.6	1 1/4"	AR-0316		ACV-0135	
S/D-1000	35.3	1 1/2"	AR-0335			
S/D-1500	53	1 1/2"	AR-0735		ACV-0735	
Quincy Pumps						
QSVB-10	79	1 1/4"	AR-0735		ACV-0735	
QSVB-20	134	1 1/4"	AR-0780		ACV-0780	
QSVI-20	159	2 1/2"	AR-0780		ACV-0780	
QSVI-40	315	2 1/2"	AR-1280		ACV-0780 (2)	
Rietschle Pumps						
VAL/VL/VE 10	6.8	NW 25	18/18	14173	CV-0118	14182
VF/VFE/CLFG 11	6.8	1/2"	18/18		CV-0118	
VF/VFE 16	10.2	1/2"	AR-0316		ACV-0135	
CLFG/CLF/CLFE 16	10.2	1/2"	AR-0316		ACV-0135	
VAL/VL/VLV 25	16.9	NW 25	AR-0316	14173	ACV-0135	14177
VF/VFE 26	16.9	3/4"	AR-0316		ACV-0135	
CLFG/CLF/CLFE 26	16.9	3/4"	AR-0316		ACV-0135	
VL/VLV 40	30	NW 25	AR-0335	14183		
VF/VFE 41	27	3/4"	AR-0335			
CLFG/CLF/CLFE 41	27	3/4"	AR-0335			
VL/VLV 60	40	3/4"	AR-0335			
VF/VFE 61	40	3/4"	AR-0335			
CLFG/CLF/CLFE 61	40	3/4"	AR-0335			
VL/VLV 80	54	NW 40	AR-0735	14174 (4)	ACV-0735	14178 (5)
VF/VFE 81	54	1	AR-0735		ACV-0735	
CLFG/CLF/CLFE 81	54	1	AR-0735		ACV-0735	
VL/VLV 100	67	NW 40	AR-0735	14174 (4)	ACV-0735	14178 (5)
VF/VFE 101	67	1 1/4"	AR-0735		ACV-0735	
CLFG/CLF/CLFE 101	67	1 1/4"	AR-0735		ACV-0735	
VWZ 102	67	NW 65	AR-0735		ACV-0735	
CLF/CLFE 141	94	1 1/2"	AR-0735		ACV-0735	
VFH/VFEH 161	108	2	AR-0780		ACV-0780	
VWZ 162	108	NW 65	AR-0780		ACV-0780	
CLF/CLFE 181	108	2"	AR-0780		ACV-0780	
VWZ 252	169	NW 65	AR-0780		ACV-0780	
CLFH/CLFEH 341	230	3"	AR-1280		ACV-0780*	
VWZ 402	270	NW 65	AR-1280		ACV-0780*	
CLFH/CLFEH 501	338	3"	AR-1680		ACV-0780*	
CLFH/CLFEH 631	426	3"	AR-1680		ACV-0780*	
CLFH/CLFEH 1001	677	3"	AR-3080		ACV-0780*	

Notes:

- 1 If no part number is listed, adaptor is not supplied by Parker. In most cases, customer can assemble adaptor from standard pipe fittings. Refer to pages 19-20.
- 2 Multiple filters piped in parallel are required.
- 3 Requires 1 1/2" Male x 1" Female reducing bushing supplied by customer.
- 4 Requires 3" Male x 1 1/2" Female reducing bushing supplied by customer.
- 5 Requires 2" Male x 1 1/2" Female reducing bushing supplied by customer.

Pump Model No.	Pump Rating CFM (Free Air)	Pump Exhaust (NPT Female Unless Otherwise Noted)	Recommended Balston Filter Non-Hazardous Non-Corrosive Applications	Balston Anodized Aluminum Pump-To-Filter Adaptor (1)	Recommended Balston Filter Hazardous and Corrosive Applications	Balston Stainless Steel Pump-To-Filter Adaptor (1)
RO-FLO Pumps (Allis-Chalmers)						
5CCA	55	1 1/2"	AR-0735		ACV-0735	
5CCB	86	1 1/2"	AR-0735		ACV-0735	
7DB	151	3"	AR-0780		ACV-0780	
7DC	235	3"	AR-1280		ACV-0780 (2)	
8DB	275	3"	AR-1280		ACV-0780 (2)	
8DE	345	3"	AR-1680		ACV-0780 (2)	
10GB	411	4"	AR-1680		ACV-0780 (2)	
10GC	593	4"	AR-3080		ACV-0780 (2)	
11S	738	5"	AR-3080			
11L	838	5"	AR-3080			
12S	970	6"	AR-3080 (2)			
12L	1080	6"	AR-3080 (2)			
17S	1228	6"	AR-3080 (2)			
17L	1420	6"	AR-3080 (2)			
19S	1693	8"	AR-3080 (2)			
19L	1920	8"	AR-3080 (2)			
23C	2270	8"	AR-3080 (2)			
23D	2740	8"	AR-3080 (2)			
27D	3300	10"	AR-3080 (2)			
33D	5950	14"	AR-3080 (2)			
Sargent-Welch Pumps						
1373	10.6	1-20	AR-0316	14163	ACV-0135	
1374	23	1-3/4-20	AR-0335	14164		
1375	35	Square Flange	AR-0335			
1376	10.6	1-20	AR-0316 (3)	14163	ACV-0135 (3)	
1380	5.6	1-20	18/18	14162	CV-0118	
1392	0.9	3/4-20	9955-12	14165	CV-0112	
1395	71	Square Flange	AR-0735		ACV-0735	
1396	100	Square Flange	AR-0735		ACV-0735	
1397	17.7	1-3/4-20	AR-0316	14160	ACV-0135	
1398	53	Square Flange	AR-0735		ACV-0735	
1399	1.2	3/4-20	9955-12	14165	CV-0112	
1400	0.9	3/4-20	9955-12	14165	CV-0112	
1402	5.6	1-20	18/18	14162	CV-0118	
1403	3.5	1-20	18/18	14162	CV-0118	
1405	2.1	3/4-20	9955-12	14165	CV-0112	
1410	0.7	1/2" Hose	9955-12		CV-0112	
8802	0.9	3/4-20	9955-12	14165	CV-0112	
8803B/8804B	0.9	3/4-20	9955-12	14165	CV-0112	
8803K/8804K	0.7	3/4-20	9955-12	14165	CV-0112	
8805	1.8	1-20	9955-12	14166	CV-0112	
8806B/K	1.8	NW 25	9955-12	14175	CV-0112	14182
8810	3.5	1-20	9955-12	14166	CV-0118	
8811B	3.5	NW 25	18/18	14173	CV-0118	14182
8811K	2.9	NW 25	9955-12	14175	CV-0112	14182
8814	5.6	NW 25	18/18	14173	CV-0112	14182
8815	5.3	1-20	18/18	14162	CV-0118	
8816B/K	5.3	NW 25	18/18	14173	CV-0118	14182
8821	7.4	NW 25	18/18	14173	CV-0118	14182
8830	10.6	1-3/4-20	AR-0316	14160	ACV-0135	
8834	12	NW 40	AR-0316	14174	ACV-0135	14184
8851	18	NW 40	AR-0316	14174	ACV-0135	14184
8861	35.3	NW 50	AR-0335	14179		
8871	53	NW 50	AR-0735	14179	ACV-0735	
8890	7.7	3/4-20	18/18	14173	CV-0118	14182
8905	1.8	NW 16	9956-12		CV-0112	14181
8910	3.8	NW 16	18/18	14172	CV-0118	14181 (4)
8910A	3.1	NW 16	18/18	14172	CV-0118	14181 (4)
8915	5.6	1-20	18/18	14162	CV-0118	
8920	7.7	NW 25	18/18	14173	CV-0118	14182

Notes:

- 1 If no part number is listed, adaptor is not supplied by Parker. In most cases, customer can assemble adaptor from standard pipe fittings. Refer to pages 19-20.
- 2 Multiple filters piped in parallel are required.
- 3 Consult factory for piping considerations.
- 4 Requires 3/4" male x 1/2" female reducing bushing supplied by customer.

Pump Model No.	Pump Rating CFM (Free Air)	Pump Exhaust (NPT Female Unless Otherwise Noted)	Recommended Balston Filter Non-Hazardous Non-Corrosive Applications	Balston Anodized Aluminum Pump-To-Filter Adaptor (1)	Recommended Balston Filter Hazardous and Corrosive Applications	Balston Stainless Steel Pump-To-Filter Adaptor (1)
Stokes Pumps						
V-005	7	NW 25	18/18	14173	CV-0118	14182
V-009	11	NW 25	AR-0316	14173	ACV-0135	14177
V-013-2	20	NW 40	AR-0316	14174		
V-017-2	36.7	NW 40	AR-0335	14174		
V-23	55	NW 40	AR-0735	14174 (3)	ACV-0735	14178 (4)
146H	30	1 1/4"	AR-0335		ACV-0335	
148H	50	1 1/2"	AR-0735		ACV-0735	
149H	80	1 1/2"	AR-0735		ACV-0735	
149HS	100	1 1/2"	AR-0735		ACV-0735	
212HS	150	2"	AR-0780		ACV-0780	
412H	300	3"	AR-1280		ACV-0780 (2)	
612H	600	3"	AR-3080		ACV-0780 (2)	
912H	728	5"	AR-3080		ACV-0780 (2)	
Ulvac Pumps						
G-5	0.21	M17 x 1	9955-12		CV-0112	
G-15	0.63	3/4"	9955-12		CV-0112	
G/GC-25S	0.84	3/4"	9955-12		CV-0112	
G/GC-20D	0.84	3/4"	9955-12		CV-0112	
G-50S/D	2.1	3/4"	9955-12		CV-0112	
GC-50D	2.1	3/4"	9955-12		CV-0112	
G-100S/D	4.2	1"	18/18		CV-0118	
GC-100D	4.2	1"	18/18		CV-0118	
GVD-050	2.1	3/4"	9955-12		CV-0112	
GVD-100	5.6	1"	18/18		CV-0118	
GVD-165	7	3/4"	18/18		CV-0118	
DA-30S	1.1	3/4"	9955-12		CV-0112	
DA-60S	2.5	3/4"	9955-12		CV-0112	
D-330D	9	1 1/2"	18/18		CV-0118	
D-650D	18	1 1/2"	AR-0316		ACV-0135	
D-950D	27	2"	AR-0335			
PKS-016	57	2"	AR-0735		ACV-0735	
PKS-030	107	3"	AR-0780		ACV-0780	
PKS-070	250	4"	AR-1280		ACV-0780 (2)	
PVD-180	6.4	3/4"	18/18		CV-0118	
PDV-360	13	1"	AR-0316		ACV-0135	
Varian Pumps						
CS/SS/SD-90	3.2	NW 25	18/18	14173	CV-0118	14182
EVAC 200	7	3/4"	18/18		CV-0118	
EVAC 300	11	3/4"	AR-0316		ACV-0135	
CD/SD-200	7	NW 25	18/18	14173	CV-0118	14182
CD/SS/SD-300	11	NW 25	AR-0316	14173	ACV-0135	14177
CD/SS/SD-700	27	NW 40	AR-0335	14174		
CD/SS/SD-1400	50	NW 40	AR-0735	14173 (3)	ACV-0735	14178 (4)
CD/SD-2500	90	NW 50	AR-0735	14179 (3)	ACV-0735	

Notes:

- 1 If no part number is listed, adaptor is not supplied by Parker. In most cases, customer can assemble adaptor from standard pipe fittings. Refer to pages 19-20.
- 2 Multiple filters piped in parallel are required.
- 3 Requires 3" Male x 1 1/2" Female reducing bushing supplied by customer.
- 4 Requires 2" Male x 1 1/2" Female reducing bushing supplied by customer.

Pump to Filter Adaptors - Straight Thread to NPT Thread

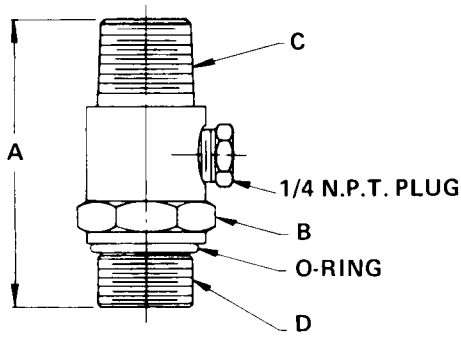

Style 1

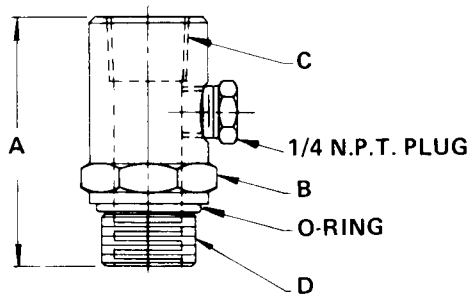

Style 2

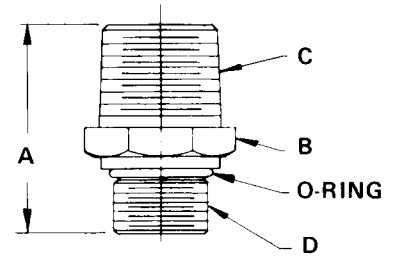

Style 3

Principal Specifications

Type	Adaptor Style	Materials of Construction		Dimensions (Inches)			
		Adaptor	Seals	(A) Height	(B) Hex Size	(C) NPT Thread	(D) Thread
14168	1	Alum.	Buna-N	3.0	1.25	3/4	M24 x 1
14166	2	↓	↓	2.6	↓	1/2 F (1)	1-20
14165	2			2.44		1/2 F (1)	3/4-20
14164	3			2.88	2.0	1 1/2	1 3/4-20
14163	3			2.19	1.38	1	1-20
14162	1			3.0	1.25	3/4	1-20
14160	3			2.3	2.0	1	1 3/4-20
14159	1			3.15	1.25	3/4	3/4 BSPT
14158	2			2.80	↓	1/2 F (1)	3/4BSPT
14157	2			2.56		1/2 F (1)	3/8 BSPT

Notes:

1 Female NPT - all others Male



Pump to Filter Adaptors - Flange to NPT Thread

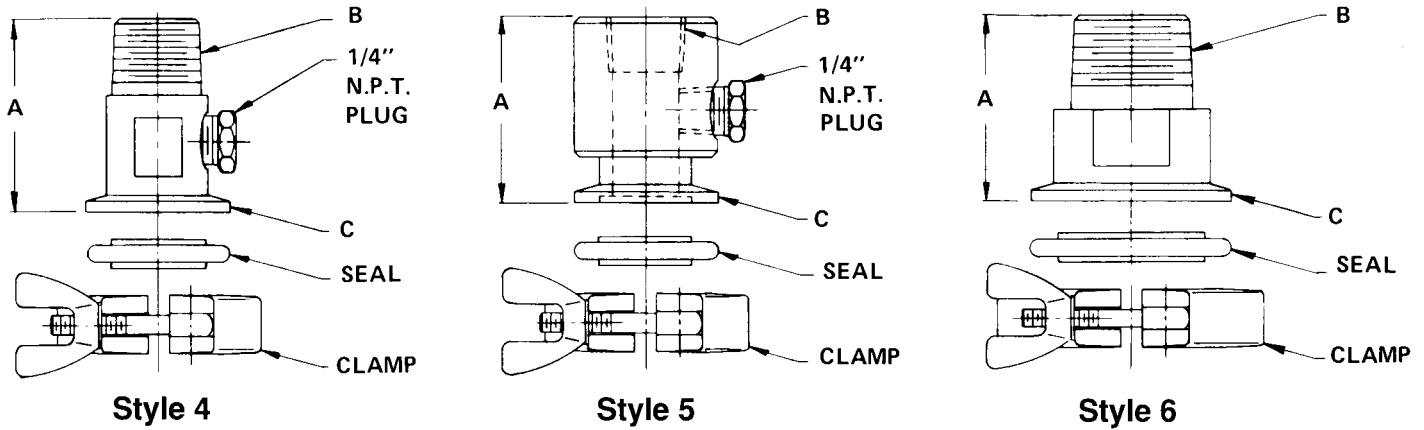

Principal Specifications

Type	Adaptor Style	Materials of Construction			Dimensions			Other Fittings Included
		Adaptor	Clamp	Seals	(A) Height (inches)	(B) NPT Thread (Inches)	(C) KF Flange (2)	
14184	6	Stain. St.	Alum.	Viton	2.0	1	KF-40	
14183	6	Alum.			2.38	1 1/2	KF-25	
14182	4	Stain. St.			2.06	1/2	KF-25	3/4" x 1/2" Reducing Bushing
14181	4	Stain. St.			2.12	1/2	KF-16	
14180	6	Alum.			2.0	1	KF-16	
14179		Stain. St.			2.62	1 1/2	KF-50	
14178					2.38	1 1/2	KF-40	
14177					2.0	1	KF-25	
14176						1	KF-16	
14175	5	Alum.				1/2 F (1)	KF-25	
14174	6					1	KF-40	1 1/2" x 1" Reducing Bushing
14173	4				2.06	3/4	KF-25	1" x 3/4" Reducing Bushing
14172	4				2.12	1/2	KF-16	1/2" coupling and 3/4" x 1/2" Reducing Bushing

Notes:

- 1 Female NPT - all others are Male
- 2 The designation "KF" and "NW" are interchangeable

Balston Liquid Filters



Filtration to 0.22 micron with exceptional filter life, even for the dirtiest liquids

Excellent chemical and solvent resistance

Compliance with FDA regulations for food contact surfaces

Seven retention efficiency grades cover the range from 75 micron to 0.22 micron

LP Depth Filters

The LP-Grades 10,20, and 30 depth filter cartridges are constructed entirely of polypropylene, and the LP-Grades 50, 60, 70, and 80 depth filter cartridges are constructed of polypropylene, borosilicate glass and polyethylene binder. Both types of cartridges provide excellent chemical and solvent resistance. All LP cartridges have a graded efficiency construction: the filtration efficiency increases from the inside surface to the outside surface, in the direction of flow. This construction provides exceptionally high solids holding capacity, which translates into a longer life of the filter cartridge. The seven retention efficiency grades offered cover the ranges from 75 micron to 0.22 micron (see table, below).

The Balston LP depth filter cartridges may be used for fine filtration of liquids with heavy dirt loading, when chemical or solvent resistance is required, or as prefilters to ultra-high efficiency or membrane filtration applications.

How To Select The Filter Cartridge

- 1 Specify the level of final filtration required, within the range of 75 micron to 0.22 micron.
- 2 Select the filter system using the Final Filter Selection Table (page 2).

Note: The recommendations are based on the assumption that the initial liquid feed is relatively dirty. If the feed has been prefiltered to about 10 micron, the first stage of filtration may be omitted.

How To Select The Filter Housing

- 1 Determine the number of LP Filter Cartridge stages and Grade of filter at each stage, using the Final Filter Selection Table on page 2.
- 2 Use the flow chart (next page) to determine the sizes of housings required based on the grade of filter cartridge and the liquid flow rate.
- 3 Select the housings of the correct size which are constructed of materials suitable for the application.

Retention Efficiency Ratings

LP Depth Filter Cartridges	
Grade	80% Capture Rating
10	75 micron
20	25 micron
30	10 micron
50	1 micron
60	0.6 micron
70	0.4 micron
80	0.22 micron

Retention efficiency v. particle size for the four finer grades of LP depth filters

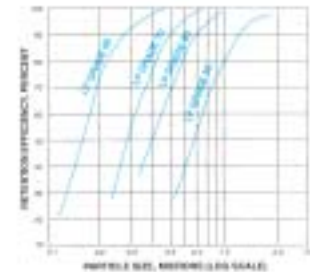

Cross Section of LP-200-50 and LP-200-95 cartridges. Construction of LP-100-12 and LP-100-25 cartridges is similar, but without end caps and gaskets.

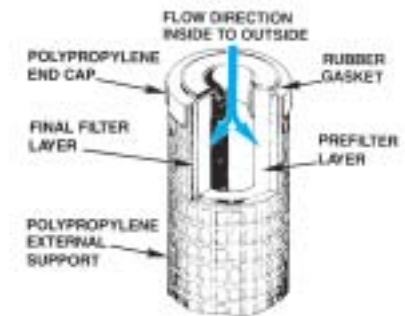

Table I Final Filter LP Depth Cartridge

If the Final Filtration Requirement is:	Use This LP Cartridge System		
	1st Stage	2nd Stage	3rd Stage
75 micron	LP Grade 10	---	---
25 micron	LP Grade 20	---	---
10 micron	LP Grade 10	LP Grade 30	---
1 micron	LP Grade 20	LP Grade 50	---
0.6 micron	LP Grade 10	LP Grade 30	LP Grade 60
0.4 micron	LP Grade 20	LP Grade 50	LP Grade 70
0.22 micron	LP Grade 20	LP Grade 50	LP Grade 80

Notes:

1 For a liquid with viscosity higher than the viscosity of water (1 centipoise), divide the flow rates in the above table by the viscosity of the liquid in centipoises. Example: for liquid with 10 centipoise viscosity, flow rate with C-0395 housing, Grade 20 cartridges at 10 psi drop will be 132/10 = 13.2 GPM.

Flow Rates of Filter with LP Cartridges

Filter Housing Model	Number of Cartridges	Cartridge Length & Designation	Initial Pressure Drop	Water Flow Rate, Gallons per Minute LP Cartridges						
				Grade 10	Grade 20	Grade 30	Grade 50	Grade 60	Grade 70	Grade 80
7700-12 33S6, 33G 58P	1	2 1/2" LP-100-12	5 psi	3.5	3.5	3.0	0.75	0.60	0.30	0.07
			10 psi	4.3	4.2	3.9	0.95	0.80	0.37	0.10
45S6 45G	1	7" LP-100-25	5 psi	5.0	5.0	4.3	1.1	0.90	0.45	0.11
			10 psi	6.2	6.2	5.4	1.4	1.2	0.60	0.15
53/18	1	5" LP-200-18	5 psi	6	6	6	3.2	1.3	0.6	0.5
			10 psi	11	11	11	6	2.5	1.0	0.9
27/50 53/50, 54/50	1	10" LP-200-50	5 psi	12	12	12	6.4	2.5	1.2	1.0
			10 psi	22	22	22	12	5	2.0	1.7
53/95, 27/95	1	20" LP-200-95	5 psi	24	24	24	13	5	2.4	2.0
			10 psi	44	44	44	24	10	4.0	3.4

Chemical and Solvent Compatibility			
Liquid	LP Cartridge	Liquid	LP Cartridge
Acetic Acid (Glacial)	NR	Hydrochloric Acid (35%)	R
Acetic Acid (5%)	R	Hydrofluoric Acid	NR
Acetone	R	Hydrogen Peroxide	NR
Acetonitrile	R	N-Methyl Pyrrolidone (NMP)	R
Alcohols	R	Methyl Ethyl Ketone (MEK)	R
Ammonia, Liquid or Gas	R (1)	Methyl Isobutyl Ketone (MIBK)	R
Amyl Acetate	N	Methylene Chloride	NR
Ammonium Hydroxide (6N)	R	Metal Etch (H ₃ PO ₄ /HAC/HNO ₃)	N
B.O.E. (NH ₄ F/HF)	NR	Nitric Acid (30%)	R
Butyl Acetate	N	Nitrobenzene	R
Carbon Tetrachloride	NR	Pentane	NR
Chlorine, Liquid or Gas	NR	Perchloroethylene	NR
Chloroform	NR	Phenol	NR
Cyclohexane	NR	Plating Solutions	R
Dimethyl Acetamide(DMAC)	R	Phosphoric Acid (50%)	R
Dimethyl Formamide(DMF)	R	Silicone Oils	R
Dimethyl Sulfoxide (DMSO)	R	Sodium Hydroxide	
Esters	NR	Below 20%	R
Ethanolamine	R	20-45%	R
Ethyl Acetate	R	Above 45%	NR
Ethylene Diamine	R	Steam	NR
Ethylene Glycol	R	Sulfuric Acid (50%)	R
Ethylene Oxide	R	Toluene	NR
Formaldehyde (37%)	R	Trichloroethane	NR
Freon TF	NR	Trichloroethylene	NR
Freon TMC	NR	Water to 180°F (82°C)	R
Hexane	NR	Xylene	NR

Notes:
 R - Recommended
 NR - Not Recommended
 N - No data available; consult factory

Chemical Compatibility:
 The above compatibility data is for the filter cartridges only, at an operating temperature of 70°F (21°C). The filter housing is not necessarily compatible with the same chemicals and solvents.

Food Grade Applications:
 All LP Filter Cartridges are constructed entirely of materials which are in compliance with FDA regulations for food contact surfaces. All stainless steel liquid filter in this bulletin comply with FDA regulations for food contact applications.

1 Grades 10, 20, 30 only.



Model 7700-12 Housing

Made of transparent nylon with 1/2" NPT in-line ports. The economical, completely disposable 7700-12 can be ordered with any grade of LP cartridge installed.

Miniature Model 58P Housing

Has a nylon head, nylon internals, and a clear nylon bowl. The Model 58P Housing accepts a single LP cartridge, and may be used to filter water, mildly acidic, or caustic solutions.

Model 53 Housings

Are all-polypropylene, designed for a single LP-200 filter cartridge. Polypropylene construction provides excellent resistance to non-oxidizing acids, such as HCL in any concentration, sulfuric to 70% concentration, brines, hydrocarbon liquids, alcohols and concentrated caustic.

The Model 53 Housings may be used with certain ketones and chlorinated solvents. Please see page 3 or contact the Technical Services Dept. for specific recommendations.



Model
7700-12



54/50



Models
53/18, 53/50,
and 53/95



Model
58P

Ordering Information						
Model	7700-12	58P	53/18	53/50	53/95	54/50
Port Size (NPT)	1/2" (1)	1/4"	3/8"	3/4"	3/4"	3/4"
Material of Construction						
Head	Nylon	Nylon	Polypropylene	Polypropylene	Polypropylene	Polypropylene
Bowl	Nylon	Nylon	Polypropylene	Polypropylene	Polypropylene	SAN
Internals	---	Nylon	---	---	---	---
Seals	---	EPR	EPR	EPR	EPR	EPR
Max. Temperature	150°F (66°C)	150°F (66°C)	125°F (52°C)	125°F (52°C)	125°F (52°C)	125°F (52°C)
Max. Pressure (2)	125 psig	125 psig	125 psig	125 psig	125 psig	60 psi
Max. Differential Press. (3)	60 psi	60 psi	60 psi	60 psi	60 psi	60 psi
Shipping Weight	1 lb. (0.5 kg)	1 lb. (0.5 kg)	3 lbs. (1.3 kg)	4 lbs. (1.8 kg)	6 lbs. (2.7 kg)	4 lbs. (1.8 kg)
Dimensions	2.6"D x 4.9"L (6.6cm x 12cm)	2.7"D x 6.1"L (6.9cm x 15cm)	4.4"D x 6.6"L (11cm x 17cm)	5.0"D x 12"L (13cm x 30cm)	5.0"D x 22"L (13cm x 56cm)	5.0"D x 12"L (13cm x 30cm)

Ordering Information						
For assistance, call toll-free at 1-800-343-4048 8AM to 5PM Eastern Time						
Model	7700-12	58P	53/18	53/50	53/95	54/50
LP Filter Cartridges, Depth Filters (4)	7700-12-□ (5)	LP-100-12-□	LP-200-18-□	LP-200-50-□	LP-200-95-□	LP-200-50-□
Number of Cartridges required	---	1	1	1	1	1

Notes:

1 Plastic barbs are available to connect the 7700-12 to plastic or rubber tubing.

7700-12 to 1/4" ID tubing
Part No. 12415 (bag of 2)

7700-12 to 1/2" ID tubing
Part No. 12416 (bag of 2)

2 Maximum pressure ratings are for temperatures to 125°F (52°C). Please consult the Technical Services Dept. for maximum pressure ratings at elevated temperatures.

3 Inside-out flow, LP filter cartridges.

4 To order filter cartridges, indicate grade by putting appropriate grade number after size designation. For example, to obtain 0.22 micron depth filter cartridges for the model 53/18, order LP-200-18-80.

5 7700-12 is supplied with any grade LP cartridge. To order, put appropriate grade number after 7700-12 designation. For example, to order with LP grade 20 cartridge, order part number 7700-12-20. 7700-12-□ filters are sold one per box.



Model 27 Housings

Model 27 housings are constructed of 316 stainless steel. These models have 1" NPT ports and are rated to 800 psig. The model 27 housings hold a single LP-200 filter cartridge, available in a 10" or 20" length.



Models
27/50, 27/95

Principal Specifications

Model	27/50	27/95
Port Size (NPT) (1)	1"	1"
Material of Construction		
Head	316 SS	316 SS
Seals	Viton	Viton
Max. Temperature (2)	180°F (82°C)	180°F (82°C)
Max. Pressure	800 psig	800 psig
Max. Differential Press. (3)	60 psi	60 psi
Shipping Weight	16 lb. (7.3 kg)	20 lb. (9 kg)
Dimensions	4.0"D X 16"L (10cm X 41cm)	4.0"D X 27"L (10cm X 69cm)

Notes:

- Adaptors are available which convert threaded ports to sanitary type clamp connections.
- Limited by maximum temperature of LP Filter Cartridges.
- Inside-out flow, LP filter cartridge.
- To order filter cartridges, indicate grade by putting appropriate grade number after size designation. For example, to obtain 0.22 micron depth filter cartridges for the model 27/50, order LP-200-50-80.

Ordering Information

For assistance, call toll-free at 1-800-343-4048 8AM to 5PM Eastern Time

Model	27/50	27/95
LP Filter Cartridges Depth Filters (4)	LP-200-50-□	LP-200-95-□
Number of Cartridges Required	1	1

Model 33S6 and 45S6 Filters

All-stainless steel with 1/2" NPT inlet and outlet ports. Both filters are also available with clear Pyrex® glass bowl (100 psig rating) with breakage-protection external plastic shield.



Models 33S6 and 45S6

Principal Specifications				
Model	33S6	33G	45S6	45G
Port Size (NPT) (1)	1/2"	1/2"	1/2"	1/2"
Material of Construction				
Head	316SS	316SS	316SS	316SS
Bowl	316SS	Pyrex	316SS	Pyrex
Internals	316SS	316SS	316SS	316SS
Seals	Viton	Viton	Viton	Viton
Max. Temperature (2)	180°F (82°C)	160°F (71°C)	180°F (82°C)	160°F (71°C)
Max. Pressure (3)	425 psig	100 psig	250 psig	100 psig
Max. Differential Press. (4)	60 psi	60 psi	60 psi	60 psi
Shipping Weight	3 lb. (1.3 kg)	3 lb. (1.3 kg)	5 lb. (2.3 kg)	5 lb. (2.3 kg)
Dimensions	2.6"D x 4.8"L (7cm x 12cm)	2.6"D x 4.5"L (7cm x 11cm)	2.6"D x 9.0"L (7cm x 23cm)	2.6"D x 9.3"L (7cm x 23cm)

Notes:

- 1 Adaptors are available which convert threaded ports to sanitary type clamp connections.
- 2 Limited by maximum temperature of LP Filter Cartridges.
- 3 Maximum pressure ratings are for temperatures to 200°F (93°C). Please consult the Technical Services Dept. for maximum pressure ratings at elevated temperatures.
- 4 Inside-out flow, LP filter cartridges.
- 5 To order filter cartridges, indicate grade by putting appropriate grade number after size designation. For example, to obtain 0.22 micron depth filter cartridges for the model 33S6, order LP-200-12-80.

Adaptor Ordering Information:

- P/N 73803 1" NPT x 1" Sanitary
- P/N 73804 1 1/2" NPT x 1 1/2" Sanitary
- P/N 73805 2" NPT c 2" Sanitary

Ordering Information				
For assistance, call toll-free at 1-800-343-4048 8AM to 5PM Eastern Time				
Model	33S6	33G	45S6	45G
LP Filter Cartridges, Depth Filters (5)	LP-100-12-□	LP-100-12-□	LP-100-25-□	LP-100-25-□
Number of Cartridges required	1	1	1	1



Filter samples to on-line liquid analyzers

Prevent cross-contamination of samples

Pressure ratings up to 125 psig

Temperature to 275°F (135°C)

Completely disposable, constructed of recyclable plastics

Disposable Filter Units

Balston Microfibre® Disposable Filter Unit (DFU) consists of a Microfibre Filter Cartridge permanently bonded into a sealed plastic holder with 125 psig pressure rating. The economical DFU offers all the advantages of Microfibre Filter Cartridges for high efficiency liquid filtrations, combined with the convenience of complete disposability. The 1/4" O.D. ports permit pressure-tight connections using standard compression fittings. Slip-on 1/4" tubing or plastic barbs may be used for low pressure applications.

The housings are available in two different materials of construction: clear nylon or corrosion-resistant (opaque) PVDF. The nylon DFU's are designated with the prefix 9933, and the PVDF DFU's are designated with the prefix 9922.

Model 9922-05

The Model 99XX-05 DFU's are the smallest DFU's available. They have an internal volume of less than 12 ml. the DFU's may be used in low flow liquid applications or sampling systems which require short retention times.

Model 9933-11

The Model 99XX-11 DFU's are similar in construction to the Model 99XX-05 DFU's, but they have approximately twice the solids holding capacity. The 99XX-11 DFU's may be used in higher flow liquid applications or in sampling applications where longer retention times are acceptable.



Model
9933-05



Model
9922-11

Retention Efficiency Ratings

DFU Grade	98% retention particle size
DQ	25 micron
CQ	8 micron
BQ	2 micron
AQ	0.9 micron
AAQ	0.3 micron

Flow Rates								
DFU Model	Volume of Housing		Initial Pressure Drop	Water Flow Rate, Gallons per Hour				
	Gallons	Liters		Grade DQ, DX	Grade CQ, CX	Grade BQ, BX	Grade AQ	Grade AAQ
9922-05	0.003	0.01	1 psi	12	10	3	1.5	0.4
4433-05			5 psi	30	25	15	7.3	1.9
9933-05			1 psi	18	15	5	2.5	0.6
9922-11	0.005	0.02	5 psi	45	37	26	12	3.1
9933-11			1 psi	18	15	5	2.5	0.6

Notes:

1 At 0 psig

2 At 110°F (43°C)

Installation Information:
Please contact the Technical Services Department for manufacturers of compression and brass fittings.

To Pressure Pipe or Tubing:
Connector 1/4" tubing to 1/4"NPT female
P/N 11970 (1 per pkg)

Connector 1/4" tubing to 1/4" tubing
P/N 11971 (1 per pkg)

To Low Pressure Plastic Tubing:

Tubing with 1/4" ID may be slipped over the DFU and fittings and held with tubing clamps. Parker supplies plastic barbs to connect the DFU to smaller diameter plastic tubing. The connection is suitable for pressures to 50 psig.

DFU to 1/16" ID tubing
P/N 14000 (bag of 20 barbs)

DFU to 1/8" ID tubing
P/N 14001 (bag of 20 barbs)

Principal Specifications						
Model	9922-05	9933-05	4433-05	9922-11	9933-11	
Inlet and Outlet Ports	1/4" Tubing	1/4" Tubing	1 st Tier/Barb 1/4"Tubing 2 nd Tier/Barb 3/8"Tubing	1/4" Tubing	1/4" Tubing	
Construction Material	PVDF	Nylon	Nylon	PVDF	Nylon	
Max. Temperature (1)	275°F (135°C)	230°F (110°C)	230°F (110°C)	275°F (135°C)	230°F (110°C)	
Max. Pressure (2)	125 psig	125 psig	125 psig	125 psig	125 psig	
Dimensions	1.0"D x 3.25"L (2.5cm x 6cm)	1.0"D x 3.25"L (2.5cm x 6cm)	1.0"D x 3.43"L (2.5cm x 8.72cm)	1.4"D x 4.6"L (3.6cm x 12cm)	1.4"D x 4.6"L (3.6cm x 12cm)	

Ordering Information						
For assistance, call toll-free at 1-800-343-4048 8AM to 5PM Eastern Time						
Model	9922-05	9933-05	4433-05	9922-11	9933-11	
Box of 10 DFUs	9922-05-□	9933-05-□	4433-05-□	9922-11-□	9933-11-□	
Grades supplied	DQ, CQ, BQ, AQ, AAQ	DQ, CQ, BQ, AQ, AAQ	DQ, CQ, BQ, AQ, AAQ	DQ, CQ, BQ, AQ, AAQ	DQ, CQ, BQ, AQ, AAQ	

Chemical Compatibility

Models 9922-05, 9922-11

Suitable: Water or steam to 275°F (135°C); concentrated nitric, sulfuric, and hydrochloric acids; chlorine (gas or liquid); sodium hypochlorite, ethylene oxide (gas or liquid); Freons; ammonia (gas, liquid, or aqueous solutions); hydrogen peroxide (all concentrations); bromine (dry and aqueous solutions); all chlorinated solvents except methylene chloride; all aromatic and aliphatic solvents; all alcohols and glycols; aniline; phenol.

Limited Use: Acetone, MEK, dioxane, furfural, methylene chloride.

Unsuitable: Water above 275°F (135°C), THF, DMF, ethylene diamine, chlorosulfonic acid, ethanolamine, pyridine, sulfur trioxide.

Models 9933-05, 9933-11, 4433-05

Suitable: Water to 158°F (70°C); benzene, toluene, other aromatic hydrocarbons; hydrocarbon solvents and fuels, perchloroethylene; trichloroethylene, nitric acid (to 10%); sulfuric acid (to 40%); hydrochloric acid (to 10%); most salt solutions; sodium and potassium hydroxide (to 50%).

Limited Use: Water at 176°F (80°C); acetone; MEK, acetaldehyde; ammonia (to 25%).

Unsuitable: Water above 158°F (70°C). alcohols; glycols, phenol; aniline; DMF; concentrated acids; chlorine.



- Remove contaminants to 5 micron
- Prevent fixture discoloration
- Materials comply with USFDA regulations
- Constructed of non-corrosive materials
- Ideal for drinking water systems
- Inexpensive replacement filter cartridges
- Transparent bowl for visual monitoring



Model
57-501

Balston Water Filter

The Balston 57-501 Series water filters provide economical, efficient liquid filtration in a one-step filter. These filters are designed to fit most 3/4" water supply lines and are available in three different efficiency ranges.

Retention Efficiency Ratings

Model	Retention efficiency Nominal µm rating	Water Flow Rate	
		5 psi	10 psi
57-501-C	80 (course grade)	15 GPM	30 GPM
57-501-M	30 (medium grade)	10 GPM	20 GPM
57-501-F	5 (fine grade)	8 GPM	16 GPM

Principal Specifications

Model	Materials of construction			Max. Press. (1)	Max. Temp.	Port Size	Shipping Weight	Dimensions
	Head	Bowl	Cartridge					
57-501-C	Polypro.	SAN	Polypro.	150 psi	125°F (52°C)	3/4" NPT	3.5 lbs.	5.5"D x 17"L (14cm x 43cm)
57-501-M	Polypro.	SAN	Polypro.	150 psi	125°F (52°C)	3/4" NPT	3.5 lbs.	5.5"D x 17"L (14cm x 43cm)
57-501-F	Polypro.	SAN	Polypro.	150 psi	125°F (52°C)	3/4" NPT	3.5 lbs.	5.5"D x 17"L (14cm x 43cm)

Notes:
1 Maximum pressure at 70°F (21°C)

Ordering Information

For assistance, call toll-free at 1-800-343-4048 8AM to 5PM Eastern Time

Model	Replacement Filter Cartridges	
	Box of 3	Box of 10
57-501-C (Course grade)	WF-3/200-50-C	WF-200-50-C
57-501-M (Medium grade)	WF-3/200-50-M	WF-200-50-M
57-501-F (Fine grade)	WF-3/200-50-F	WF-200-50-F
Mounting Bracket Kit	P/N 11057	

Balston Filters and Air Dryers for Hospital Applications



Steam Filters

Eliminate instrument staining, spotting, and rusting

Reduced contamination of sterilizer interiors

Reduced maintenance

SMART Dryer™

Meets new NFPA 99/2002 Medical Air Specification of 32°F dewpoint

Output capacities to 400 scfm

Durable - will hold up to the dirtiest compressed air system

Balston Steam Filters

The 23R Steam Filter contains a patented Microfibre® Filter Cartridge in a rugged stainless steel housing designed especially for steam service. Included as standard items with the 23R Steam Filter are a stainless steel condensate drain and a high quality bleeder valve. The unit, as received, is complete and ready for installation. Install the filter on the hospital steam line, directly upstream from the sterilizer control valve.

Balston SMART Dryer™ Medical Air Dryers

Now, there is only one sensible way to dry compressed air and comply with the new NFPA 99/2002 specification! High efficiency, durable membrane technology is quickly becoming the standard for drying compressed air. Parker Hannifin is leading the way with membrane technology that consumes the least amount of compressed air for drying.



Model 23/75R

How the Balston Steam Filter Works

The 23R Steam Filter contains a patented Microfibre® Filter Cartridge in a rugged stainless steel housing designed especially for steam service. Included as standard items with the 23R Steam Filter are a stainless steel condensate drain and a high quality bleeder valve. The unit, as received, is complete and ready for installation. Install the filter on the hospital steam line, directly upstream from the sterilizer control valve.

Steam enters the housing and moves into an expansion chamber, where much of the condensate is removed from the steam by the abrupt change in flow direction and velocity. The steam then flows upward in the housing, through the Grade R Microfibre filter cartridge, and downward to the exit port. The water draining from the filter cartridges and expansion chamber is removed from the housing by the automatic condensate drain.

The Grade R Microfibre filter cartridge, the heart of the 23R Steam Filter, combines sturdy construction with remarkably efficient filtration of solid particles and liquid droplets. The cartridge is rated at 98+% at 0.1 micron. Solid particles remain trapped in the depth of the filter cartridge, and liquid water drips from the filter cartridge to the automatic drain. The Microfibre filter cartridge is constructed from chemically inert borosilicate glass fibers and fluorocarbon resin binder. The filter cartridge is completely free of impurities which could extract into the steam.

The Balston 23/75R Steam Filter is recommended for use on 3/4" and 1" steam lines (line sizes for the vast majority of hospital sterilizers). Please consult our technical support department for recommendations on filters for larger steam lines. Use only products designed specifically for steam filtration in steam installations.

Principal Specifications

Model	Port Size	Filter Cartridge Designation	Materials of Construction			Seals	Maximum Steam Pressure	Shipping Weight
			Head	Bowl	Internals			
23/75R	1" NPT (1)	200-75-R (2)	304SS	304SS	304SS	EPR	80 psig	25 lbs. (11 kg)

Ordering Information

For assistance, call toll-free at 1-800-343-4048 8AM to 5PM Eastern Time

Model	Automatic Drain	No. Filter Cartridges Required	Replacement Filter Cartridges (box of 15)
23/75R	Included	1	200-75-R

Notes:

1 The 1" port size can be installed in a 3/4" line by using the appropriate reducing bushings.

2 Each filter is supplied with one filter cartridge installed. Replacement filter cartridges are sold in boxes of 15. To order, use complete size and grade designation; for example 200-75-R.

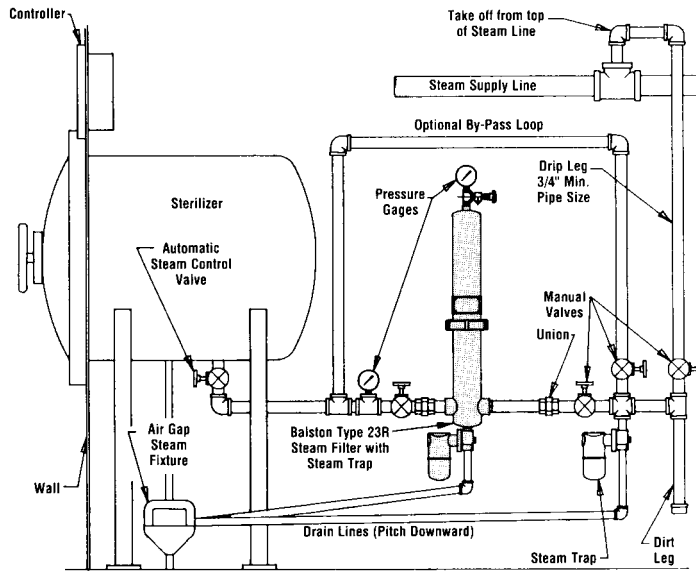

Recommended Installation



Unique, graded efficiency design provides exceptionally long filter life

Reduces costly sterilizer maintenance

Easy to change filter cartridge - no tools required

Safe, inert materials of construction

Filtering Water with the Balston LP-20 Water Filter

Dirt and rust in the hot or cold water supply to washer-sterilizers leave deposits and stains on valuable instruments and sterilizers. In most hospitals, the cleanliness of the water depends upon the efficiency of the municipal water treatment system. Excessive dirt in the water can be an intermittent problem caused by a drought, a fire in the neighborhood, water main problems, or scores of other random events well beyond the control of the hospital engineers. This unpredictable, expensive problem can be permanently solved by installing an inexpensive and easily maintained Balston LP Grade 20 water filter on the water line to the washer-sterilizer. On any washer-sterilizer, installing a Balston 23R Steam Filter on the steam line and a Balston LP Grade 20 Water Filter on the water line guarantees freedom from the outside contaminants.

How the cartridge works

The LP Grade 20 liquid filter cartridge is constructed entirely from polypropylene, rendering it safe and inert for use in hospital water supplies. The polypropylene construction makes this filter acceptable for use in cold and hot (to 180°F/82°C) water supplies. The filter cartridge consists of a polypropylene external support structure with EPR seals and an internal filtering element. The internal filter is made of self-bonded polypropylene fibers which are graded from coarse to fine in the direction of flow (inside-to-outside). Since the coarse inner layer acts as a prefilter for the finer outer layer, the life of this cartridge is exceptionally long. For example: Approximately 50,000 gallons of water can be filtered by a single 20" liquid filter cartridge.



Model C-0195



Model 53/50



Model 53/95

Model C-0195

This model is a rugged, stainless steel housing for hot water service. One cartridge is securely mounted with an internal tierod and threaded cartridge retainer. This model accommodates the 20" length filter cartridge.

Models 53/50 and 53/95

These models are constructed entirely of polypropylene and designed for a single filter cartridge in the 10" and 20" lengths. The Model 53 housings are used for cold water service only.

Filter Assembly Selection Recommendations

Water Line Size (1)	Hot Water (125°F/52°C-180°F/82°C)	Cold Water (below 125°F/52°C)
3/4"	C-0195 with LP-200-95-20	53/95 with LP-200-95-20
1/2"	—	53/50 with LP-200-50-20

Principal Specifications

Model	Port Size	Materials of Construction				Maximum Temperature	Maximum Pressure	Maximum Diff. Press. (1)	Shipping Weight	Dimensions
		Head	Bowl	Internals	Seals					
HOT WATER FILTER										
C-0195	1" NPT	304SS	304SS	304SS	EPR	180°F (82°C)	150 psig	60 psig	11 lbs (5 kg)	4"D x 28"L (10cm x 71cm)
COLD WATER FILTER										
53/50	3/4" NPT	Polypro.	Polypro.	---	EPR	125°F (52°C)	125 psig	60 psig	4 lbs (2 kg)	5"D x 12"L (13cm x 31cm)
53/95	3/4" NPT	Polypro.	Polypro.	---	EPR	125°F (52°C)	125 psig	60 psig	6 lbs (3 kg)	5"D x 22"L (13cm x 56cm)

Ordering Information

For assistance, call toll-free at 1-800-343-4048 8AM to 5PM Eastern Time

Model	No. Filter Cartridges Required (2)	Filter Cartridge Designation
C-0195	1	LP-200-95-20
53/50	1	LP-200-50-20
53/95	1	LP-200-95-20

Notes:

- 1 LP Grade 20 Filter Cartridge. Inside-to-outside flow.
- 2 Filter Cartridge not included with housing and must be ordered separately.



Long filter life

Easy to change filter cartridge

Eliminate unexpected downtime due to clogged components

Stainless steel and Teflon® provide safe, trouble-free operation



Model A34

Model A34

The cleanliness of Ethylene Oxide (EtO) typically varies from supplier to supplier and from delivery to delivery. In addition, EtO inherently polymerizes, causing valves to clog and regulators to malfunction. Filtering EtO at the point of use assures the delivery of clean EtO to the sterilizers, significantly improves sterilizer performance, and reduces sterilizer maintenance.

Balston EtO Filters, specifically designed for ethylene oxide service, are constructed of stainless steel with Teflon seals. The ET Grade 30 filter cartridge is inexpensive and simple to replace when necessary.

The model A34 is sized for most hospital sterilizer applications.

*Teflon® is a registered trademark of the Dupont Company.

Principal Specifications								
Model	Port Size	Filter Cartridge Designation	Materials of Construction			Seals	Maximum Steam Pressure	Shipping Weight
			Head	Bowl	Internals			
A34	1/4" NPT	ET-100-12-30 (1)	316SS	316SS	316SS	Teflon (2)	250 psig	4 lbs. (2 kg)

Ordering Information	
For assistance, call toll-free at 1-800-343-4048 8AM to 5PM Eastern Time	
Model	Filter Cartridge Designation
A34 Included	ET-100-12-30

Notes:
1 Each filter is supplied with one filter cartridge installed.

2 Each filter is supplied with one spare Teflon seal set.

Meets new NFPA 99/2002 Medical Air Specification of 32°F Dewpoint

State-of-the-art membrane technology

Guaranteed 32°F dewpoint

Durable - will hold up to the dirtiest compressed air system

No requirement for costly maintenance contracts

Output capacities to 400 scfm

Complete system with prefilters, autodrains, and differential pressure indicator



State-of-the-Art Membrane Technology

Water vapor from the compressed air supply passes through the hollow fibers of the membrane. At the same time, a small portion of the dry air product is redirected along the length of the fibers to sweep out the water vapor which has permeated the membrane. The moisture-laden sweep gas is then vented to the atmosphere, and clean, dry air is supplied to the compressed air distribution system.

The SMART Dryer™ utilizes sophisticated technology to monitor the air consumption and automatically adjusts the regenerative sweep flow as required. The variable sweep system results in significant energy savings and low operating costs. (NFPA 3025 and NFPA 3050 are fixed sweep systems)

Desiccant / Pressure swing adsorption technology is the only other technology that will meet this new NFPA specification. But this technology is designed to produce -40°F to -100°F dew point which results in high operating costs, in terms of both electrical costs and maintenance costs. The initial capital cost is also higher than that of membrane technology.

The SMART Dryer technology has been specifically designed to produce the required NFPA dew point. In addition, there are no desiccant towers to maintain and change out periodically. No heaters required nor final

filters to capture desiccant particles from traveling out into the facility and to sensitive tools and medical equipment.

The Balston SMART Dryer Medical Air Dryer is designed to operate continuously, 24 hours a day, 7 days a week with the only maintenance requirement of changing the prefilter cartridges twice a year - a 5 minute procedure requiring no tools!

Applications	Benefits
Medical Air	Easy to install - no electrician required to install or maintain system
General Compressed Air Mainlines	
Process Controls	No refrigerants or freons - environmentally friendly
HVAC Systems	
Instrument Cabinets	Similar configuration of inlet/outlet ports to that of refrigerant dryers for easy replacement installation
Fire and Sprinkler Systems	
Pneumatic Controls	Complete system with prefilters, auto drains, and pressure gauges
Dry Air for Hazardous Areas	
Chemical Blanketing and Packaging	
Laser Optics	

*Non-cycling refrigerant air dryer

** Ref pg 99-38 - Section 5.1.3.5.7

Membrane Air Dryer - Principles of Operation

Phase I

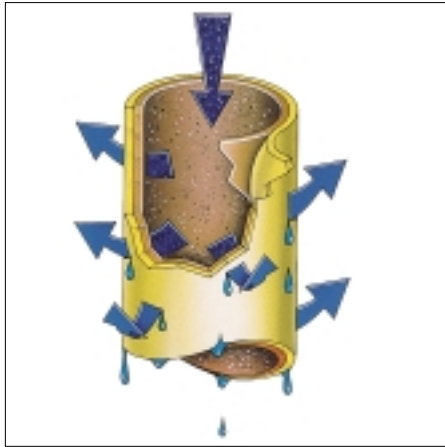

Figure 1

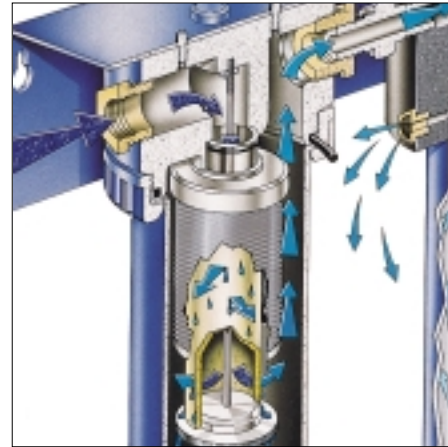

Figure 2

Phase II



Figure 3

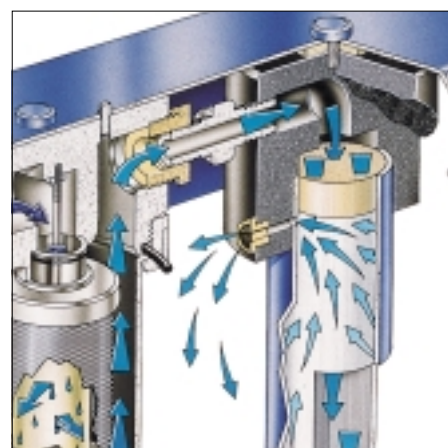

Figure 4

Phase I - Coalescing Filtration

Prior to entering the membrane drying module, the compressed air passes through a high efficiency water separator and coalescing filter to remove oil and water droplets and particulate contamination with an efficiency of 99.99% at 0.01 micron. The liquids removed by the filter cartridge continuously drip from the filter cartridge into the bottom of the housing, where they are automatically emptied by an autodrain assembly (see Fig. 1 and Fig. 2). The air leaving the prefilter, therefore, is laden only with water vapor, which will be removed in the membrane module.

Phase II - Drying

The water vapor in the compressed air is removed by the principle of selective permeation through a membrane (see Fig. 3). The membrane module consists of bundles of hollow membrane fibers, each permeable only to water vapor. As the compressed air passes through the center of these fibers, water vapor permeates through the walls of the fiber, and dry air exits from the other end of the fiber. A small portion of the dry air (regeneration flow) is redirected along the length of the membrane fiber to carry away the moisture-laden air which surrounds the membrane fibers (see Figure 4). The remainder of the dry air is piped to the application.

- (1) Components complying with 5.1.3.5.4 through 5.1.3.5.10, arranged per 5.1.3.5.11
- (2) An automatic means to prevent backflow from all on-cycle compressors through all off-cycle compressors
- (3) A manual shutoff valve to isolate each compressor from the centrally piped system and from other compressors for maintenance or repair without loss of pressure in the system
- (4) Intake filter-muffler(s) of the dry type
- (5) Pressure relief valve(s) set at 50 percent above line pressure
- (6) Piping between the compressor and the source shutoff valve compatible with oxygen, that does not contribute to contaminant levels and is cleaned for oxygen use

5.1.3.5.3.3 Medical air compressor systems shall preclude the condensation of water vapor in the piping distribution system by the selection of the air drying equipment.

5.1.3.5.4 Compressors for Medical Air.

5.1.3.5.4.1* Compressors for medical air shall be designed to prevent the introduction of contaminants or liquid into the pipeline by either of the following methods:

- (1) Elimination of oil anywhere in the compressor (e.g., liquid ring and permanently sealed bearing compressors)
- (2) Separation of the oil-containing section from the compression chamber by at least two seals creating an area open to atmosphere that allows the following:
 - (a) Direct and unobstructed visual inspection of the interconnecting shaft through vent and inspection openings no smaller than 1.5 shaft diameters in size
 - (b) The facility operators to confirm proper seal operation by direct visual inspection through the above-shaft opening, without disassembly of the compressor (e.g., extended head compressors with an atmospheric vent between the compression chamber and the crankcase)

5.1.3.5.4.2 For liquid ring compressors, service water and seal water of a quality recommended by the compressor manufacturer shall be used.

5.1.3.5.4.3 Compressors shall be permitted to be constructed of ferrous and/or non-ferrous materials.

5.1.3.5.4.4 Anti-vibration mountings shall be installed for compressors as required by equipment dynamics or location and in accordance with the manufacturer's recommendations.

5.1.3.5.4.5 Flexible connectors shall connect the air compressors with their intake and outlet piping.

5.1.3.5.5 Aftercoolers. Aftercoolers, where required, shall be provided with individual condensate traps. The receiver shall not be used as an aftercooler or aftercooler trap.

5.1.3.5.5.1 Aftercoolers shall be permitted to be constructed of ferrous and/or non-ferrous materials.

5.1.3.5.5.2 Anti-vibration mountings shall be installed for aftercoolers as required by equipment dynamics or location and in accordance with the manufacturer's recommendations.

5.1.3.5.6 Medical Air Receivers. Receivers for medical air shall meet the following requirements:

- (1) Be made of corrosion resistant materials or otherwise be made corrosion resistant
- (2) Comply with Section VIII, Unfired Pressure Vessels, of the ASME *Boiler and Pressure Vessel Code*

- (3) Be equipped with a pressure relief valve, automatic drain, manual drain, sight glass, and pressure indicator
- (4) Be of a capacity sufficient to prevent the compressors from short-cycling

5.1.3.5.7 Medical Air Dryers. Medical air dryers shall meet the following requirements:

- (1) Be designed to provide air at a maximum dew point that is below the frost point [0°C (32°F)] at any level of demand
- (2) Be sized for 100 percent of the system peak calculated demand at design conditions
- (3) Be permitted to be constructed of ferrous and/or non-ferrous materials
- (4) Be provided with anti-vibration mountings installed as required by equipment dynamics or location and in accordance with the manufacturer's recommendations

5.1.3.5.8 Medical Air Filters. Medical air filters shall meet the following requirements:

- (1) Be appropriate for the intake air conditions
- (2) Be located upstream of the final line regulators
- (3) Be sized for 100 percent of the system peak calculated demand at design conditions and be rated for a minimum of 98 percent efficiency at 1 micron or greater
- (4) Be equipped with a continuous visual indicator showing the status of the filter element life
- (5) Be permitted to be constructed of ferrous and/or non-ferrous materials

5.1.3.5.8.1 Compressors complying with 5.1.3.5.4.1(2) shall be provided with the following:

- (1) Coalescing filters with element change indicators
- (2) Charcoal absorbers with colorimetric hydrocarbon indicators

5.1.3.5.9 Medical Air Regulators. Medical air regulators shall meet the following requirements:

- (1) Be sized for 100 percent of the system peak calculated demand at design condition
- (2) Be permitted to be constructed of ferrous and/or non-ferrous materials
- (3) Be equipped with a pressure indicator indicating delivery pressure

5.1.3.5.10* Medical Air Local Alarm. A local alarm complying with 5.1.9.4 shall be provided for the medical air compressor source.

5.1.3.5.11 Piping Arrangement and Redundancies.

5.1.3.5.11.1 Component arrangement shall be as follows:

- (1) Components shall be arranged to permit service and a continuous supply of medical air in the event of a single fault failure.
- (2) Component arrangement shall be permitted to vary as required by the technology(ies) employed, provided an equal level of operating redundancy and medical air quality is maintained.

5.1.3.5.11.2 Medical air compressors shall be sufficient to serve the peak calculated demand with the largest single compressor out of service. In no case shall there be fewer than 2 (two) compressors.

5.1.3.5.11.3 When aftercoolers are provided, they shall be sufficient to serve the peak calculated demand with the largest single aftercooler out of service and provided with valves ad-

* Printed with permission from the NFPA, Quincy, MA 02269

Principal Specifications

		Membrane Air Dryers					
Model Number	NFPA3025NA	NFPA3050NA	NFPA5100NA	NFPA5200NA	NFPA5300NA	NFPA5400NA	
CSA Safety Standard	CAN/CSA 22.2 No.1010.1-92						
IEC 1010 Safety Standard	IEC 1010-1: 1990 + A1:1992 + A2:1995/EN61010-1:1993						
EIC 1010	Installation Category II, Pollution Degree 2						
UL Safety Standard	UL 3101-1, First Edition						
Max Flow Rate @32°F dewpoint	25 SCFM	50 SCFM	100 SCFM	200 SCFM	300 SCFM	400 SCFM	
Dewpoint (1)	32°F (0°C)						
Min/Max Inlet Air Temp.(2)	40°F/100°F (4°C/38°C)						
Ambient Temp. Range	40°F/95°F (4°C/35°C)						
Min/Max Inlet Pressure	80 psig/150 psig (5.5 barg/10 barg)						
Max Relative Humidity	80%						
Altitude	2000M						
Max Compressed Air Requirement	31 SCFM	62 SCFM	120 SCFM	240 SCFM	360 SCFM	480 SCFM	
Max Pressure Drop (5)	6 psi (0.4 bar)						
Inlet/Outlet Port Size	1/2"NPT(male)	3/4"NPT(male)	1"NPT(male)	1-1/2"NPT(male)	2"NPT(male)	3"NPT(male)	
Electrical Requirements	120 VAC, 60 Hz, 1 Amp						
Fuse Type	T, 250V, 1 Amp@120 VAC						
Physical Dimensions	18"wx34"hx13"d (46cmx87cmx32cm)	26"wx57"hx18"d (66cmx145cmx45cm)	12.5"wx44"hx16"d (32cmx112cmx40cm)	12.5"wx44"hx16"d (32cmx112cmx40cm)	12.5"wx43.25"hx27"d (32cmx112cmx68cm)	12.5"wx43.25"hx27"d (32cmx112cmx68cm)	
Shipping Weight	65 lbs(30 kg)	175 lbs(79 kg)	175 lbs(80 kg)	225 lbs(102 kg)	300 lbs(136 kg)	375 lbs(170 kg)	

Ordering Information For assistance call 1-800-343-4048

Model Number	NFPA3025NA	NFPA3050NA	NFPA5100NA	NFPA5200NA	NFPA5300NA	NFPA5400NA
Coalescing Prefilter Assembly	76915-DX 76915-BX	76962-DX 76962-BX	2312N-1B1-DX 2312N-1B1-BX	A15/80-DX A15/80-BX	C02-2356 C02-2357	C02-2358 C02-2359
Replacement Prefilter Cartridges (every 6 mos)	100-18-DXE 100-18-BXE	150-19-DXE 150-19-BXE	200-35-DX 200-35-BX	200-80-DX 200-80-BX	210-800-DX 210-800-BX	210-955-DX 210-955-BX
Membrane Module	D01-0048	D01-0077	D01-0086 (ea.)	D01-0086 (4ea.)	D01-0086(6ea.)	D01-0086(8ea.)
Automatic Drain Kit	N/A	N/A	21552	21552	21552	21552
Drip Leg Drain	N/A	N/A	A01-0086	A01-0086	A01-0086	A01-0086

- Notes:**
- 1 Product dewpoint is 32°F or lower at all demand conditions (see table 1)
 - 2 Inlet compressed air dewpoint must not exceed the ambient air temperature.
 - 3 If compressed air is extremely contaminated, a Balston Grade DX prefilter should be installed directly upstream from the membrane dryer.
 - 4 Max. compressed air requirement is at 100 psig operating pressure. For max. compressed air consumption at other pressures, see tables 1 and 2.
 - 5 Max pressure drop measured at max flow rate @ 100 psig. Pressure drop will increase at lower feed pressures - consult factory.

Table 1

Outlet Flow (SCFM) at Indicated Operating Pressure (PSIG) for 32°F Pressure Dew Point				
Model Number	60 psig	80 psig	100 psig	120 psig
NFPA3025NA	10	17.5	25	32.5
NFPA3050NA	20	35	50	65
NFPA5100NA	40	70	100	130
NFPA5200NA	80	140	200	260
NFPA5300NA	120	210	300	390
NFPA5400NA	160	280	400	520

Technical Drawings

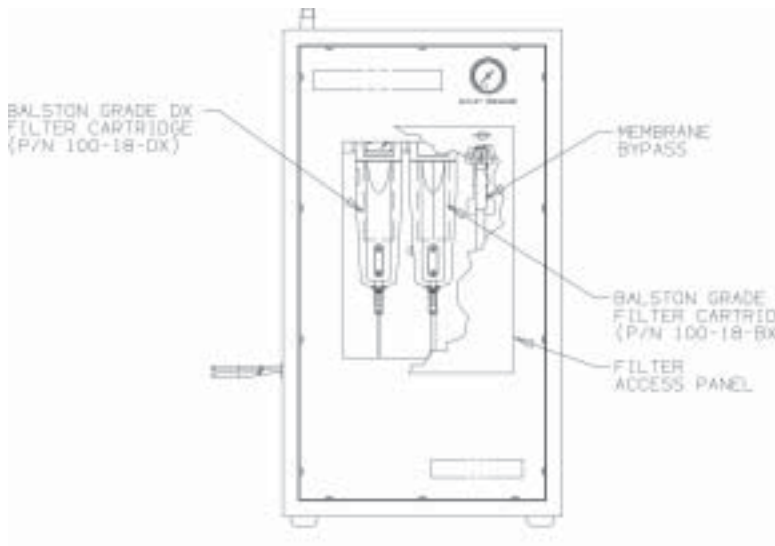

Model NFPA 3025NA

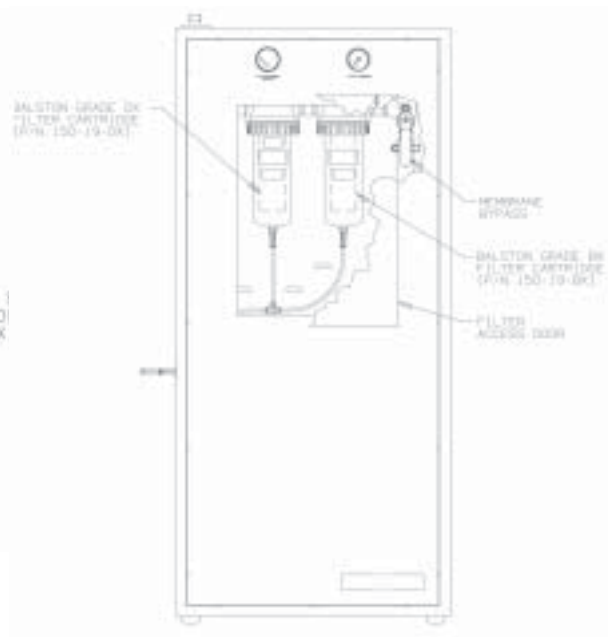

Model NFPA 3050NA



Model NFPA5100
Front View

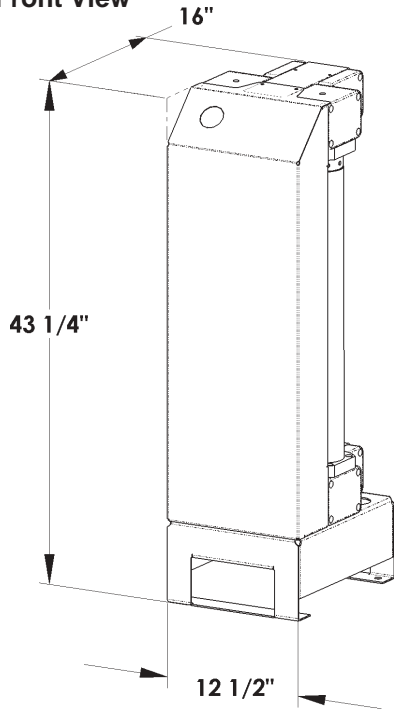

Model NFPA5200
Front View

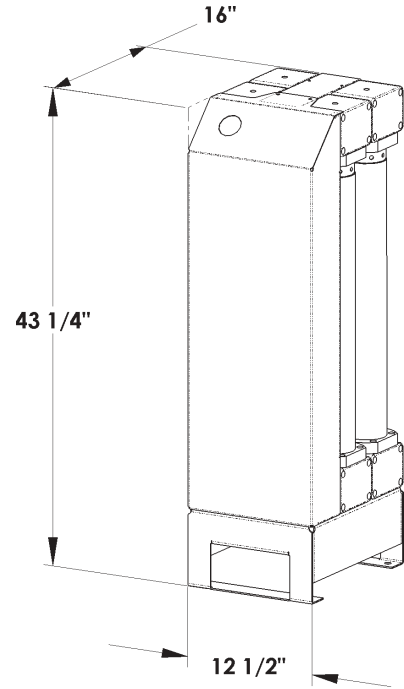

Model NFPA5300
Front View

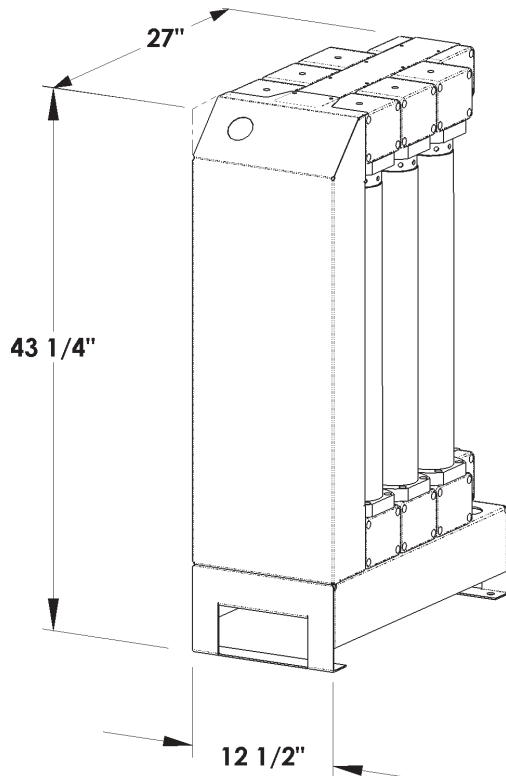

Model NFPA5400
Front View

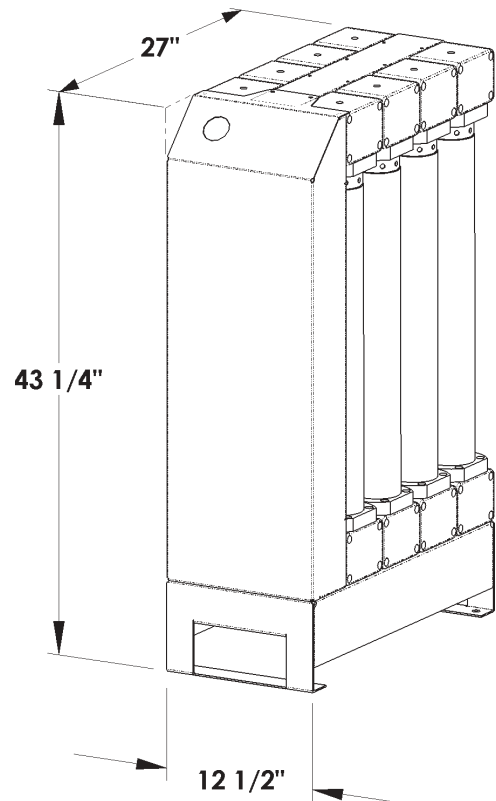

Balston Natural Gas Filters



*Pressure rating to
1440 psig*

*Meets U.S. and
Canadian codes for
natural gas filters*

*Flow rates to 183
million standard cubic
feet per day*

*High efficiency
removal of suspended
liquid and solid
impurities*

Balston Compressed Gas Filters

Balston high flow rate compressed gas filters offer exceptionally high efficiency coalescing filtration of compressed gas at high flow rates. Specifically designed to remove suspended liquids and dirt from pipeline natural gas, the housings are ASME Code Stamped up to 1440 psig. Equipped with Balston Microfibre[®] Grade DXE Disposable Filter Cartridges, the filters are rated at 93% retention of 0.01 micron and essentially 100% retention of 1 micron liquid droplets and particles.

NEW

from Parker Balston!

Energy Saving Filter Cartridges!

New and improved with the same filter performance you have come to expect from Balston cartridges, the new XE-Cartridges will reduce your annual operating costs!

What is creating the operating cost?

For every 2 psi of differential pressure in a compressed air system, the drive energy on the compressor is increased by 1%.
By minimizing differential pressure drop through compressed air filters, less drive energy on the compressor is realized and thus lower energy costs.

What is the savings solution?

The new XE-Cartridges from Parker Balston exhibit a 2+ psi pressure drop improvement over the current X cartridge. This produces a cost savings of \$27.00 to \$240.00 per year per installed filter cartridge depending on the number of work shifts.*

How do I order them?

For your next order of filter cartridge replacements be sure to order the NEW XE-Cartridges! Just simply add an "E" for energy savings to the end of the part number! See example below.

Current Part # 100-18-DX	New Part # 100-18-DXE
-----------------------------	--------------------------

Now is the time to outfit your entire facility with the
NEW Parker Balston XE-Cartridge!

**If you have any questions please feel free to call us at
800-343-4048 and ask for Technical Services Department.**

*based on \$0.07 Kwh as a national average electrical cost. Savings are more significant
in higher cost regions!





Model AKC-0280



Model AKC-0880

Balston Compressed Gas Filters

Balston high flow rate compressed gas filters offer exceptionally high efficiency coalescing filtration of compressed gas at high flow rates. Specifically designed to remove suspended liquids and dirt from pipeline natural gas, the housings are ASME Code Stamped up to 1440 psig. Equipped with Balston Microfibre® Grade DXE Disposable Filter Cartridges, the filters are rated at 93% retention of 0.01 micron and essentially 100% retention of 1 micron liquid droplets and particles.

Since the coalesced liquid drains continuously from the filter cartridges as rapidly as it is collected, the filters have an unlimited capacity for liquid removal.

Each filter cartridge is mounted on a rigid permanent filter holder with a vibration-resistant removable tube retainer. The filter cartridge is self-gasketing, and the filter holder is designed so that a perfect seal is easily made, even when the tube is replaced by an operator unfamiliar with the equipment.

Series AKC, AKH, and AHC housings are available with inlet and outlet ports covering the range from 2" to 10" pipe sizes. The standard carbon steel units have pressure ratings from 200 to 1440 psig.

Each AKC assembly is equipped with an automatic float drain, differential pressure indicator, and a set of filter cartridges. Each AHC assembly is equipped with internal support cores and one set of filter cartridges. Also available is a complete line of stainless steel filter housings ASME code stamped for a rated maximum operating pressure of 200 psig.



Principal Specifications

Model	Port Size Flange (7)	Closure Type*	Maximum Temperature (3)	Maximum Pressure (1)	Shipping Weight	Dimensions (8)	Flange to Flange Dimension
AHC-0180-[]	2"	SD	130°F (54°C)	1440 psig	98 lbs.(44 kg)	32"H x 15"W x 4.5" (81cm x 38cm x 11cm)	14.5" (37cm)
AKC-0280-[]	3"	FSO	230°F (110°C)	250 psig	140 lbs.(63 kg)	36"H x 16"W x 8" (91cm x 41cm x 20cm)	15.62" (40cm)
AKH-0280-[]	3"	FSO	250°F (121°C)	665 psig	235 lbs.(107 kg)	41"H x 16"W x 8" (104cm x 41cm x 20cm)	15.63" (40cm)
AHC-0280-[]	3"	SD	130°F (54°C)	1440 psig	220 lbs.(100 Kg)	43"H x 17"W x 12" (109cm x 43cm x 30cm)	16.63" (42cm)
AKC-0480-[]	4"	FSO	230°F (110°C)	250 psig	210 lbs.(95 kg)	36"H x 21"W x 6" (91cm x 53cm x 15cm)	20.63" (52cm)
AKH-0480-[]	4"	FSO	250°F (121°C)	665 psig	270 lbs.(122 kg)	40"H x 21"W x 6" (102cm x 53cm x 15cm)	20.63" (52cm)
AHC-0480-[]	4"	SD	130°F (54°C)	1440 psig	450 lbs.(204 kg)	50"H x 21"W x 15" (127cm x 53cm x 38cm)	20.63" (52cm)

Notes:

1 Vessel is ASME Section VIII, Div. 1 code stamped for rated pressure. All AKC housing designs have CRN registration numbers assigned in all Canadian provinces.

Model	Port Size Flange (13)	Materials of Construction	Maximum Temperature	Maximum Pressure (10)	Shipping Weight	Dimensions (8, 11)	Flange to Flange Dimension
KS-0280-3	3"	316SS Housing, Viton Seals	200°F (93°C)	200 psig	140 lbs.	36"h x 15.6"w x 7.75" (91cm x 40cm x 20cm)	15.62" (40cm)
KS-0480-4	4"	316SS Housing, Viton Seals	200°F (93°C)	200 psig	210 lbs.	35.5"h x 20.6"w x 6.25" (90cm x 52cm x 16cm)	20.63" (52cm)

Notes:

1 Vessel is ASME Section VIII, Div. 1 code stamped for rated pressure. All AKC housing designs have CRN registration numbers assigned in all Canadian provinces.

2 All vessels are constructed of carbon steel with Type 303 stainless steel filter cartridge holders and Buna-N seals.

3 Maximum operating temperature of carbon steel vessel is 650°F (343°C). Minimum operating (process and ambient) temperature is -20°F (-30°C).

Max. Temp.

250°F (121°C)
400°F (204°C)
500°F (260°C)

Seal Material

Buna
Viton
Silicone

4 Model 20-211 drain is installed on all AKC housings. Maximum operating pressure for the 20-211 drain is 400 psig.

5 Model 41-071 Differential Pressure Indicator (DPI) is installed on all AKC housings. Maximum operating pressure for 41-071 DPI is 250 psig. This DPI is not recommended for natural gas applications.

6 Differential Pressure Indicator and Automatic Drain are not included with AHC and AKH Assemblies. Series AHC Assemblies are equipped with internal support cores and one set of filter cartridges.

7 ANSI Flange Classes:

AKC Series: 150 lbs. R.F.S.O.
AKH Series: 300 lbs. R.F.S.O.
AHC Series: 600 lbs. R.F.S.O.

8 Dimensions are height x width x center of flange-to-floor height.

*Closure Abbreviations:

SD: Screw type closure with Buna N "O" ring

FSO: Flat (flanged) top with swing bolts and Buna N "O" ring.

Ordering Information

For assistance, call toll-free at 1-800-343-4048 8AM to 5PM Eastern Time

Model	Automatic Float Drain	Differential Pressure Indicator (5)	Filter Cartridges No. Required	Box of 10 Cartridges (1)
AHC-0180-DX	---	---	1	200-80-DX
AKC-0280-DX	20-211	41-071	2	200-80-DX
AKH-0280-DX	20-211 (8)	---	2	200-80-DX
AHC-0280-DX	---	---	2	200-80-DX
AKC-0480-DX	20-211	41-071	4	200-80-DX
AKH-0480-DX	20-211 (8)	---	4	200-80-DX
AHC-0480-DX	---	---	4	200-80-DX
KS-0280-3	20-211 or 20-440 (14)	---	2	200-80-□
KS-0480-4	20-211 or 20-440 (14)	---	4	200-80-□

Notes:

9 To order filter cartridges, indicate Grade by putting appropriate letters after size designation. For example, to order Grade DXE cartridges for KS-0280-3 housing, order 200-80-DXE. Microfibre Filter Cartridges are sold in boxes of 10.

10 Vessel is ASME Section VIII, Division 1 code stamped for rated pressure at 200°F. Maximum pressure ratings are for temperatures to 200°F. Please consult factory for maximum pressure ratings at elevated temperatures.

11 All dimensions are approximate. Request certified drawing for installation dimensions.

12 Requires element retainer #27900, one for each cartridge. Order separately.

13 All flanges are ANSI 150#RFSSO.

14 20-211 Auto Float Drain, 20-440 Auto Electric Solenoid Drain.

Principal Specifications							
Model	Port Size Flange (7)	Closure Type*	Maximum Temperature (3)	Maximum Pressure (1)	Shipping Weight	Dimensions (8)	Flange to Flange Dimension
AKC-0880-[]	6"	FSO	250°F (121°C)	200 psig	360 lbs.(163 kg)	38"h x 25"w x 7.5" (97cm x 64cm x 19cm)	24.75" (63cm)
AKH-0880-[]	6"	FSO	250°F (121°C)	665 psig	560 lbs.(254 kg)	43"h x 25"w x 8.5" (109cm x 64cm x 22cm)	24.75" (63cm)
AHC-0880-[]	6"	SD	130°F (54°C)	1440 psig	980 lbs.(445 kg)	54"h x 25"w x 18" (137cm x 64cm x 46cm)	24.75" (63cm)
AKC-1480-[]	8"	FSO	250°F (121°C)	200 psig	590 lbs.(268 kg)	54"h x 34"w x 16" (137cm x 86cm x 41cm)	34" (86cm)
AKH-1480-[]	8"	FSO	250°F (121°C)	665 psig	1120 lbs.(508 kg)	54"h x 34"w x 16" (137cm x 86cm x 41cm)	34" (86cm)
AKC-2280-[]	10"	FSO	250°F (121°C)	200 psig	880 lbs.(400 kg)	56"h x 36"w x 17" (142cm x 91cm x 43cm)	36" (91 cm)
AKH-2280-[]	10"	FSO	250°F (121°C)	665 psig	1430 lbs.(649 kg)	57"h x 36"w x 17" (145cm x 91cm x 43cm)	36" (91 cm)

Model	Port Size Flange (13)	Materials of Construction	Maximum Temperature	Maximum Pressure (10)	Shipping Weight	Dimensions (8, 11)	Flange to Flange Dimension
AKS-0880-[]	6"	316SS Housing, Viton Seals	200°F (93°C)	200 psig	360 lbs.(163 kg)	38"h x 24.75"w x 7.5" (97cm x 63cm x 19cm)	24.75" (63cm)
AKS-1480-[]	8"	316SS Housing, Viton Seals	200°F (93°C)	200 psig	590 lbs.(268 kg)	54"h x 34"w x 16.25" (137cm x 86cm x 41cm)	34" (86cm)
AKS-2280-[]	10"	316SS Housing, Viton Seals	200°F (93°C)	200 psig	880 lbs.(400 kg)	56"h x 36"w x 17.25" (142cm x 91cm x 44cm)	36" (91cm)

Ordering Information				
For assistance, call toll-free at 1-800-343-4048 8AM to 5PM Eastern Time				
Model	Automatic Float Drain	Differential Pressure Indicator (5)	Filter Cartridges No. Required	Box of 10 Cartridges
AKC-0880-DX	20-211	41-071	8	200-80-DXE
AKH-0880-DX	20-211 (4)	---	8	200-80-DXE
AHC-0880-DX	---	---	8	200-80-DXE
AKC-1480-DX	20-211	41-071	14	200-80-DXE
AKH-1480-DX	20-211 (4)	---	14	200-80-DXE
AKC-2280-DX	20-211	41-071	22	200-80-DXE
AKH-2280-DX	20-211 (4)	---	22	200-80-DXE
AKS-0880-DX or BX	20-211 or 20-440 (14)	---	8	200-80-DXE or BXE
AKS-1480-DX or BX	20-211 or 20-440 (14)	---	14	200-80-DXE or BXE
AKS-2280-DX or BX	20-211 or 20-440 (14)	---	22	200-80-DXE or BXE



High Pressure Filter Housings

Flow Rate at 2 psi Drop at Indicated Line Pressure with 200-80-DX filter Cartridges														
Assembly	40 psig		100 psig		200 psig		400 psig		600 psig		1000 psig		1400 psig	
	MM SCFD	SCFM	MM SCFD	SCFM	MM SCFD	SCFM	MM SCFD	SCFM	MM SCFD	SCFM	MM SCFD	SCFM	MM SCFD	SCFM
AHC-0180	0.8	595	1.8	1250	3.3	2340	6.5	4515	9.4	6700	15.9	11050	22.2	15400
AKC-0280														
AKH-0280	1.7	1190	3.6	2500	6.7	4680	13.0	9030	19.2	13400	31.8	22100	44.4	30800
AHC-0280														
AKC-0480														
AKH-0480	3.5	2430	7.3	5100	13.8	9550	26.5	18400	39.5	27300	64.9	45100	90.5	62900
AHC-0480														
AKC-0880														
AKH-0880	7.0	4910	14.8	10300	27.8	19300	53.6	37200	79.5	55200	131	91100	183	127000
AHC-0880														
AKC-1480														
AKH-1480	12.3	8580	25.9	18000	48.5	33700	93.6	65050	139	96400	---	---	---	---
AKC-2280														
AKH-2280	19.2	13350	40.3	28000	75.4	52400	145	101000	216	150000	---	---	---	---

MM SCFD = Million Standard Cubic Feet per Day

SCFM = Standard Cubic Feet per Minute

Stainless Steel Filter Housings

Flow Rate (SCFM) at 2 psi Drop at Indicated Line Pressure								
Assembly	Grade	2 psig	20 psig	60 psig	80 psig	100 psig	150 psig	200 psig
AKS-0280	DXE	364	760	1630	2065	2500	3600	4680
	BXE	90	190	400	510	620	890	1160
AKS-0480	DXE	760	1540	3320	421	5100	7300	9550
	BXE	180	380	810	1025	1240	1780	2320
AKS-0880	DXE	1500	3120	6710	8505	10300	14800	19300
	BXE	360	750	1620	2050	2480	3560	4640
AKS-1480	DXE	2620	5450	11720	14860	18000	25800	33700
	BXE	630	1310	2830	3585	4340	6230	8120
AKS-2280	DXE	4080	8470	18230	23115	28000	40200	52400
	BXE	1000	2070	4460	5655	6850	9840	12800

0.01 Micron Membrane Filters

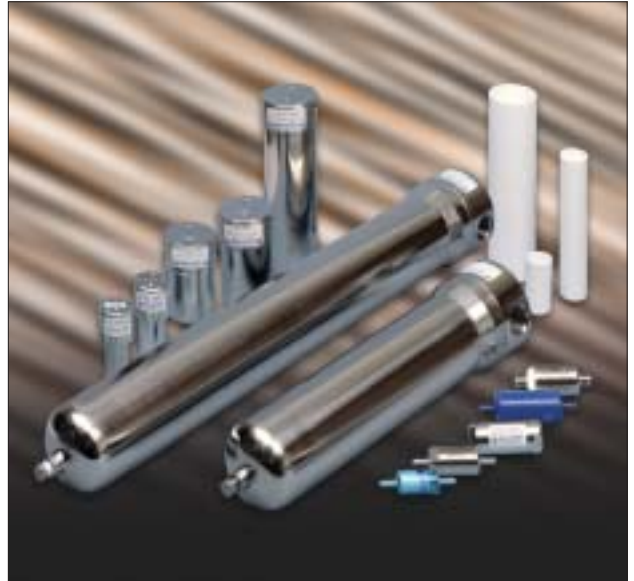

*Filtration to 0.01
micron*

No particle shedding

*Integral prefilter
protects the mem-
brane*

*Corrosion resistant
 housings*

Pressure to 5,000 psig

*PTFE membrane with
glass and fluorocarbon
prefilter*

*Chemically inert to
most gases*

Easy to install

GS Series Membrane Filters

The Balston GS Series Membrane Filter Cartridges combine absolute membrane filtration down to 0.01 μm , with an integral pre-filter to protect the membrane.

Ideally suited for high purity compressed air and gas requirements, these membrane cartridges are available in several housing configurations shown above.

Use as a Final Filter for:

- Ultra-high purity gases
- Corrosive or toxic gases
- Cylinder gases
- Doping gases

0.01 µm Membrane Filters

The GS Membrane Cartridges represent state-of-the-art membrane filtration technology. An integral prefilter, bonded to a porous PTFE membrane, provides the user with extended membrane life, 0.01 µm filtration rating, and, most importantly, zero fiber shedding. The Balston GS Membrane filter also offers excellent chemical compatibility as a result of the inert materials of construction. All of these features combine to make the Balston GS cartridges the ideal choice for critical process gas filtration requirements.

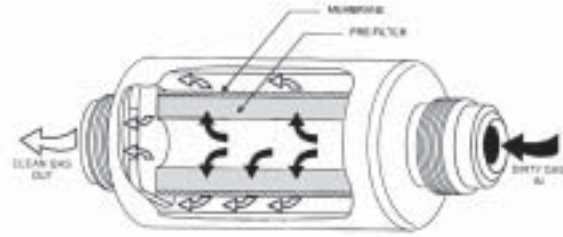

Membrane Life Expectancy Comparison

Balston GS Membrane Cartridges, with their unique integral prefilter, offer up to 18 times the operating life of conventional membrane cartridges (as indicated in the life expectancy comparison below).

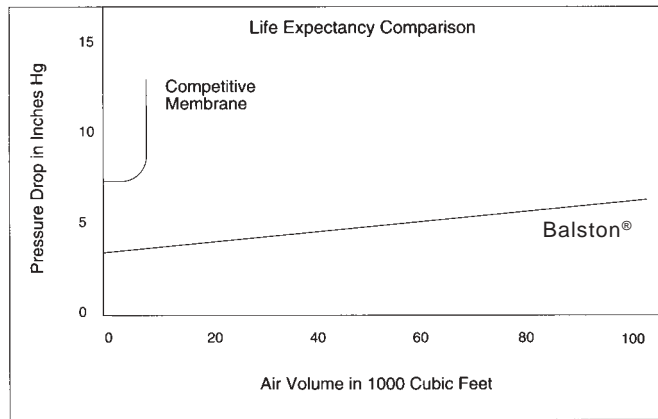

Physical Properties, GS Membrane Cartridges

Temperature Range	-40°F to 250°F (-40°C to 121°C)
Maximum pressure differential across membrane, Inside-to-outside flow:	20 psi (size code 100 and 200) 60 psi (size code 050)
Materials of Construction:	Borosilicate glass with fluorocarbon resin binder prefilter and PTFE membrane
Retention Efficiency:	0.01 µm

Retention Efficiency Rating

The retention efficiencies of the Balston GS Series membrane cartridges were derived by John McCarthy, a staff research scientist at M.I.T. Dr. McCarthy used a submicron particle detection and sizing device to collect and analyze the filter efficiency data. The test procedure consisted of challenging the membrane filter with a sodium chloride aerosol solution which contained aerosol particles in a narrowly defined size range. Downstream from the filter, the effluent gas was evaluated for particulate contaminant size using a condensation nucleus counter.

There was no detectable penetration of 0.01 µm particles through the membrane filters. Bulletin TI-834 details the efficiency rating procedure and experimental results of this study.

Chemical Compatibility

The GS Series Membrane Filter cartridges are compatible with the following gases (when installed in a stainless steel filter housing with Teflon® * seals).

Ammonia	Chlorine (dry)	Hydrogen Bromide
Air (Compressed)	Diborane	Methylene Chloride
Argon	Dichlorosilane	Nitrogen
Arsine	Fluorine (dry)	Nitrous Oxide
Boron Trichloride	Freon	Phosphorous Oxychloride (dry)
Carbon Dioxide	Helium	Phosphine
Carbon Tetrafluoride	Hydrogen	Silane

**Teflon® is a registered trade mark of the Dupont Company.



Disposable Filter Units (DFU's)

Consist of a membrane filter and an integral prefilter, permanently bonded into a plastic housing. DFU's have pressure ratings to 125 psig, and may be installed using a variety of fitting systems.

9933-05-95

Available in a transparent nylon housing, this DFU is an ideal choice for an economical membrane filter for use where its chemical compatibility is suitable.

9922-11-95

This opaque PVDF DFU, with approximately double the membrane area of the 9933-05-95, is used where exceptional chemical compatibility is required.



Model 9933-05-95



Model 9922-11-95

Principal Specifications

Model	9933-05-95	9922-11-95
Inlet and Outlet Ports	1" Tube	1" Tube
Materials of Construction		
Housing	Nylon	PVDF
Cartridge	PTFE/Glass	PTFE/Glass
Seals	None	None
Maximum Temperature	230°F(110°C)	250°F(121°C)
Maximum Pressure	125 psig	125 psig
Maximum Δ Pressure	60 psi	60 psi
Shipping Weight	0.1 lb (45 g)	0.2 lb (90 g)
Dimensions	3.25"H X 1.0"W (8cm X 2.5cm)	4.6"H X 1.43"W (12cm X 3.6cm)

Ordering Information

For assistance, call toll-free at 1-800-343-4048

Filter Assembly (1) Complete with Membrane Filter Cartridge	Description
9933-05-95	In-line Nylon disposable filter with GS Membrane Cartridge
9922-11-95	In-Line disposable PVDF filter with GS Membrane Cartridge

Notes:

1 Disposable Filter Units are sold in boxes of 3 or 10. For example, a box of 3 DFU's in nylon housings, order: 3/9933-05-95. For a box of 10, order: 9933-05-95.

97S6

Miniature 316 stainless steel filter, with 1/4" NPT in-line ports, 5000 psig rating. The 97S6 has a replaceable membrane cartridge and is an economical alternative when a disposable product is not required.

91S6, 95S6, 95T

Miniature T-Type filters in 316 stainless steel. The 91S6 is rated for 650 psig, the 95S6 is rated for 5000 psig. The 95T is constructed of PTFE, and is rated at 150 psig. The membrane cartridge is changed without breaking the inlet or outlet connections.

31S6, 33S6

Have 1/4" or 1/2" ports, 425 psig rating, can handle a higher gas flow rate, and have greater solids holding capacity than the Type 95 filters.

41S6, 45S6

Are higher flow rate stainless steel filters with 1/4" or 1/2" NPT ports. The Type 45, with stainless steel bowl, has a 250 psig rating.



Model 97S6



Model 91S6, 95S6, 95T
(95S6 Shown)



Model 31S6, 41S6
(31S6 Shown)



Model 33S6, 45S6
(45S6 Shown)



Principal Specifications

Model	97S6	91S6	95S6	95T	31S6, 33S6	41S6, 45S6
Inlet and Outlet Ports	1/4" NPT (3)	1/8" NPT (2,3)	1/8" NPT (2,3)	1/8" NPT (2,3)	1/2" NPT (2,3)	1/2"NPT (2,3)
Drain Port	None	1/8" NPT	1/8" NPT	1/8" NPT	1/4" , 1/8" NPT (7)	1/4" , 1/8" NPT (7)
Materials of Construction						
Head	316SS	316SS	316SS (5)	Teflon (5)	316SS	316SS
Bowl	316SS	316SS	316SS (5)	Teflon (5)	316SS	316SS
Internals	316SS	316SS	316SS (5)	Teflon (5)	316SS	316SS
Seals	Viton (6)	Teflon (4)	Teflon (4)	Viton (4,6)	Viton (6)	Viton (6)
Maximum Temperature	400°F(204°C)	400°F(204°C)	400°F(204°C)	300°F(149°C)	400°F(204°C)	400°F(204°C)
Maximum Pressure	5000 psig (1)	650 psig (1)	5000 psig (1)	150 psig (1)	425 psig (1)	250 psig (1)
Shipping Weight	0.8 lbs (0.4 kg)	1.2 lbs. (0.5 kg)	1.3 lbs. (0.6 kg)	0.5 lbs. (0.2 kg)	5 lbs. (2.3 kg)	5.5 lbs. (2.5 kg)
Dimensions	1.25"D X 3.1"L (3.2cm X 7.9cm)	1.5"D X 3.7"L (3.8cm X 9.4cm)	1.8"D X 4"L (4.6cm X 10.2cm)	1.8"D X 4"L (4.6cm X 10.2cm)	2.25"D X 5.5"L (31S6) 2.6"D X 4.5"L (33S6) (5.7cm X 14cm) (31S6) (2.6cm X 4.5cm) (33S6)	2.25"D X 10"L (41S6) 2.6"D X 9"L (45S6) (5.7cm X 25.4cm)(41S6) (6.6cm X 22.9cm) (45S6)

Ordering Information

For assistance, call toll-free at 1-800-343-4048 8AM to 6PM Eastern Time

Housing Only Model	Membrane Cartridge No. Required	Membrane Cartridges (Order Separately)	
		Box of 3	Box of 10
97S6	1	GS-3/050-05-95	GS-050-05-95
91S6	1	GS-3/050-11-95	GS-050-11-95
95S6	1	GS-3/050-11-95	GS-050-11-95
95T	1	GS-3/050-11-95	GS-050-11-95
31S6, 33S6	1	GS-3/100-12-95	GS-100-12-95
41S6, 45S6	1	GS-3/100-25-95	GS-100-25-95

Notes

1 Maximum pressure ratings are for temperatures to 200°F (93°C). Please consult factory for maximum pressure ratings at elevated temperatures.

2 Also available with 1/4" NPT ports, use designation Type 33S6-1/4 or 45S6-1/4.

3 Available with 1/4" socket weld for tubing size OD ports, use designation 97SW, 95SW, 33SW, 45SW, etc. Please consult factory for special pricing.

4 Teflon encapsulated Viton seals are standard.

5 Constructed of materials which comply with NACE Specification MR-01-75. Request Certificate of Compliance.

6 Teflon®/Teflon® encapsulated Viton and other seals are available upon request. Please consult factory.

7 Drain port for types 31S6 & 41S6 is 1/4".

Teflon® is a registered Trademark of the Dupont Co.

37/12, 37/25

316 stainless steel T-Type filters, 4000 psig rating. The Model 37 filters are also used when a larger line size or higher flow rate is required.

Principal Specifications

Model	37/12	37/25
Inlet and Outlet Ports	1/2" NPT (5)	1/2" NPT (5)
Drain Port	1/8" NPT	1/8" NPT
Materials of Construction		
Head	316SS (2)	316SS (2)
Bowl	316SS (2)	316SS (2)
Internals	316SS (2)	316SS (2)
Seals	Viton (4)	Viton (4)
Maximum Temperature	400°F(204°C)(1)	400°F(204°C)(1)
Maximum Pressure	4000 psig	4000 psig
Shipping Weight	6 lb (2.7 kg)	10 lb (4.5 g)
Dimensions	2.75"Dia X 5.75"L (7cm X 14.6cm)	2.75"Dia X 10.25"L (7cm X 26cm)



Model 37/12, 37/25
(37/25 Shown)

Ordering Information

For assistance, call toll-free at 1-800-343-4048

Housing Only Model	Membrane Cartridges (Order Separately)	
	Box of 3	Box of 10
37/12	GS-3/100-12-95	GS-100-12-95
37/25	GS-3/100-25-95	GS-100-25-95

Notes

1 Maximum pressure ratings are for temperatures to 200°F (93°C). Please consult factory for maximum pressure ratings at elevated temperatures.

2 Constructed of materials which comply with NACE Specification MR-01-75. Request Certificate of Compliance.

3 Available with 1/2" socket weld for tubing size OD ports, use designation 37/12SW, 37/25SW.

4 Teflon/Teflon encapsulated Viton and other seals are available upon request. Please consult factory.

5 For 1" line sizes up to 800 psig, consult factory.



Flow Rates

Filter Housing	Flow Rates, SCFM, at 2 psi Drop at Indicated Line Pressure (psig)													
	2	20	60	100	125	150	200	300	500	1000	2000	3000	4000	5000
9933-05-95	0.5	1.0	1.5	2.0	2.2	--	--	--	--	--	--	--	--	--
9922-11-95	0.5	1.0	1.7	2.2	2.3	--	--	--	--	--	--	--	--	--
91S6	0.5	1.0	1.8	2.5	2.8	3.0	3.4	4.1	5.3	--	--	--	--	--
95S6	0.5	1.0	1.8	2.5	2.8	3.0	3.4	4.1	5.3	7.4	10.5	12.9	14.8	16.5
95T	0.5	1.0	1.8	2.5	2.8	3.0	--	--	--	--	--	--	--	--
97S6	0.5	1.0	1.7	2.3	2.5	2.7	3.1	3.7	4.8	6.7	9.4	11.5	13.3	14.9
31S6, 33S6	1.0	2.1	4.6	7.0	7.7	8.4	9.6	11.6	--	--	--	--	--	--
37/12									14.8	20.8	29.3	35.9	41.4	--
41S6, 45S6	3.0	6.0	13.0	20.0	22.0	24.0	27.4	--	--	--	--	--	--	--
37/25								33.1	42.4	59.5	83.8	102.0	118.0	--

Balston Steam and Sterile Air Filters for the Food Industry

Remove 98+% of 0.01 micron particles

Remove liquid condensate at the same efficiency as for solid particles

Remove essentially all nonvolatile boiler feedwater chemicals

Comply with USFDA, USDA, Health Protection Branch of Health and Welfare Canada, and 3-A accepted practices

Stop carryover of boiler feedwater chemicals



NEW

from Parker Balston!

Energy Saving Filter Cartridges!

New and improved with the same filter performance you have come to expect from Balston cartridges, the new XE-Cartridges will reduce your annual operating costs!

What is creating the operating cost?

For every 2 psi of differential pressure in a compressed air system, the drive energy on the compressor is increased by 1%.
By minimizing differential pressure drop through compressed air filters, less drive energy on the compressor is realized and thus lower energy costs.

What is the savings solution?

The new XE-Cartridges from Parker Balston exhibit a 2+ psi pressure drop improvement over the current X cartridge. This produces a cost savings of \$27.00 to \$240.00 per year per installed filter cartridge depending on the number of work shifts.*

How do I order them?

For your next order of filter cartridge replacements be sure to order the NEW XE-Cartridges! Just simply add an "E" for energy savings to the end of the part number! See example below.

Current Part # 100-18-DX	New Part # 100-18-DXE
-----------------------------	--------------------------

Now is the time to outfit your entire facility with the
NEW Parker Balston XE-Cartridge!

**If you have any questions please feel free to call us at
800-343-4048 and ask for Technical Services Department.**

*based on \$0.07 Kwh as a national average electrical cost. Savings are more significant in higher cost regions!



Balston® Steam Filters

Balston Series SR Filters are in full compliance with the requirements of the US Food, Drug and Cosmetic Act. They also meet the regulations for Indirect Food Additives used as Basic Components for Repeated Use Food Contact Surfaces as specified in 21 CFR Part 177, and Current Good Manufacturing Practices, 21 CFR Part 110. These filters have been accepted by the USDA for use in federally inspected meat and poultry plants. Balston Steam Filters are in full compliance with the 3A Accepted Practices (Number 609-00) for producing steam of culinary quality. They are also in full compliance with the requirements of the Health Protection Branch of Health and Welfare Canada.

Benefits

Balston Steam Filters eliminate particulate contamination of food products caused by direct contact with dirty steam. Other benefits include: reduction in steam condensate mixing with food products when steam is used for agitating, mixing, or cooking; eliminate taste and odor problems by reducing boiler feedwater carryover; Reduced maintenance requirements.



Model 23/75SR



Model SP6-23/75SR



Recommended Steam Filters

For 3/4" and 1" Steam Lines

Model 23/75SR is recommended in smaller lines with a steam flow of up to 500 lbs. per hour. The filter is complete with filter cartridge, steam trap, and bleeder valve.

For 1-1/2" Steam Lines

Model SP3-23/75SR is recommended. It will filter up to 1500 lbs. of steam per hour. Each of the three filters has its own steam trap. A master trap disposes of most condensate before it reaches the filters. Manifolds can be connected to flow from left to right or right to left.

For 2" Steam Lines

Model SP4-23/75SR is recommended. It will filter up to 2000 lbs. of steam per hour. The Model SP6-23/75SR will filter up to 3000 lbs of steam per hour. Steam trap and manifold features are the same as the Model SP3-23/75.

Notes:

- 1 Each SP3, SP4, SP6 filter is supplied mounted on a stand.
- 2 Constructed of food grade EPR.
- 3 Each Steam Filter Assembly is supplied with filter cartridges installed.

Principal Specifications

Model	23/75SR	SP2-23/75SR	SP3-23/75SR	SP4-23/75SR	SP6-23/75SR
Port Size	1" NPT	1 1/2" NPT	1 1/2" NPT	2" NPT	2" NPT
Max Pressure	125 psig	125 psig	125 psig	125 psig	125 psig
Flow Rate	500 lbs/hr	1000 lbs/hr	1500 lbs/hr	2000 lbs/hr	3000 lbs/hr
Materials of Construction	304 SS	304 SS	304 SS	304 SS	304 SS
Seals (2)	EPR	EPR	EPR	EPR	EPR
Shipping Wt	26 lbs. (12 kg)	Approx. 110 lbs	190 lbs. (86 kg)	220 lbs. (100 kg)	280 lbs. (127 kg)
Dimensions	7"W X 35"L (18cmX88cm)	22"W X 46"L X 11"D (56cmX117cmX28cm)	29"W X 48"L X 21"D (74cmX122cmX53cm)	36"W X 48"L X 21"D (91cmX122cmX53cm)	50"W X 48"L X 21"D (74cmX122cmX53cm)

Ordering Information

For assistance, call toll-free at 1-800-343-4048 8AM to 5PM Eastern Time

Model	23/75SR	SP2-23/75SR	SP3-23/75SR	SP4-23/75SR	SP6-23/75SR
Replacement Filter Cartridges (Box of 10) (3)	200-75-SR	200-75-SR	200-75-SR	200-75-SR	200-75-SR
Filter Cartridges per housing	1	2	3	4	6

Remove all viable organisms

USDA accepted for use in federally inspected Meat and Poultry plants

Low pressure drop

Full compliance with FDA requirements

Balston® Sterile Air Filters

Balston grade SA filter cartridges, rated at 99.9999+% efficiency for 0.01 micron particles, is at least 30 times better than the accepted standard for sterile air filters developed by independent research organizations in the U.S. and U.K. (request Bulletin TI-105A for a detailed discussion on Balston filter efficiency rating procedure, and Bulletin TI-935 for an independent test report on Balston Sterile Air Filters). Balston Sterile Air Filters are in full compliance with the requirements of the FDA.

Here's what one of your colleagues found:

A Balston sterile air filter assembly, consisting of Models 200X Series, was tested at the University of Massachusetts, Department of Food Science and Nutrition, under the direction of Professor David A. Evans, Ph.D.

"This sterile air system produced commercially sterile air and, to the limits of detection, no viable colonies of microorganisms were found".

- Professor David A. Evans, Ph.D.



Model 200X Series



Model 2104 Series



Model 2206, 2208



Model 2312



Model A15/80

Filter Cartridge Description

1st Stage: Grade DXE	2nd Stage: Grade BXE	3rd Stage: Grade SA
For removal of large quantities of oil, water, and dirt from compressed air. Prefilter to	Grade BX. For complete removal of trace	quantities of oil, water, and dirt. For removal of bacteria when providing sterile air.

Physical Properties, Microfibre Filter Cartridges

Temperature Range	-150°F to 300°F (-100°C - 149°C)
Maximum Pressure	100 psi (60 psi for Grade SA Filter)
Differential Across Filter, Inside-to-Outside Flow:	Tubes)
Materials of Construction	Borosilicate glass microfibers with fluorocarbon resin binder. Resistant to water, all hydrocarbon and synthetic lubricants.

Retention Efficiency

Grade	Efficiency for 0.01 Micron Particles and Droplets
DXE	93% @ 0.01 µm
BXE	99.99% @ 0.01 µm
SA	99.9999+% @ 0.01 µm

Balston Filter Cartridge and Housing Selection

Balston provides two grades of coalescing filter cartridges, Grade DXE and Grade BXE. Singly or in tandem, these filters satisfy all requirements for removing liquid and solid contaminants from compressed air. These filters are recommended as prefilters in sterile air systems. The Balston Grade SA filter removes bacteria from compressed air. It is the final filter in a sterile air system.

How to Select the Filter Cartridge and Housing

- 1 Decide which grade(s) of filter cartridges fits the application (see selection boxes at left).
- 2 Select the filter housing with a port size equal to the line size where the filter is to be located.
- 3 For a new installation in which the line size has yet to be selected, determine the gas flow rate and pressure at the point where the filter will be located, and then refer to the flow chart on the reverse side of this data sheet. The filter port size must be equal to or larger than the line size (when specified).
- 4 If the sterile air filter assembly requires steam sterilization, stainless steel filter assemblies specifically designed for in-line steam sterilization must be used. These assemblies are identified by the RED print in the flow chart on the next page.

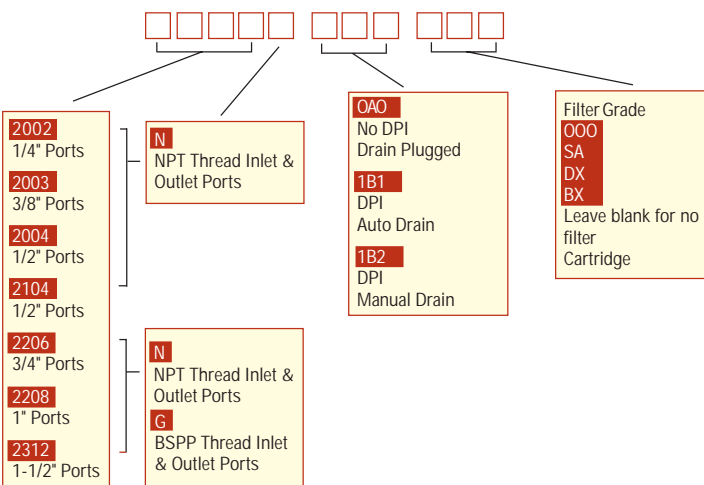

How to Order the Filter Assembly

- 1 Build your own custom filter assembly using the guideline matrix to the left and specify your model number. Example: 1/2" filter with DPI and Auto Drain with Grade DXE Filter = 2104N-1B1-DXE.
- 2 Each assembly is shipped with the filter cartridge installed. To order additional filter cartridges, indicate the model number of the cartridges, and the grade. Examples 100-12-DXE, 100-12-BXE, or 100-12-SA, etc.



Steam Sterilization Procedure

In installations where the sterile air filter requires steam sterilization, we recommend the following procedures:

The steam sterilization pressure should not exceed 60 psig. Preferably, it should be held to 40 psig or less. A typical sterilization cycle is 30 psig steam for 30 minutes. Steaming time can be increased as desired without harm to the filter cartridges. The steam flow should not exceed the normal air flow for the unit. To ensure no buildup of condensate in the housing, condensate should be drained from the filter by a condensate drain valve during the steaming process.

The cleanliness of the steam is an important factor influencing the life of the Sterile Air Filter cartridges. Parker strongly recommends using Model 23 Steam Filters to ensure optimum operating life (see steam filter section of this literature pack).

When autoclaving, the Grade SA filter cartridges will tolerate temperatures to 300°F (149°C) in dry gas. Viton or other heat resistant seals should be used in the housing.

Filter Assemblies Assemblies in BLUE are maximum Recommended for Steam Sterilization				Flow rates (SCFM), at 7 psi drop at indicated line pressure (over 3 stages) Refer to Principal Specification Charts in each product data sheet for pressure rating of each housing						
1st Stage	2nd Stage	3rd Stage	Port Size	20	40	60	80	100	125	150
2002N-IBI-DX	2002N-IBI-BX	2002N-OAO-SA A33B-SA	1/4	8	11	16	21	25	31	36
2104N-IBI-DX	2104N-IBI-BX	2104N-OAO-SA A45B-SA	1/2	19	30	41	51	63	76	90
2208N-IBI-DX	2208N-IBI-BX	2208N-OAO-SA A27/35B-SA	1	23	37	50	64	77	94	111
2312N-IBI-DX	2312N-IBI-BX	2312N-OAO-SA A27/80B-SA (1)	1 1/2	46	74	101	129	155	189	223
A15/80-DX	A15/80-BX	A15/80-SA A15/80-SA	2	94	148	202	256	310	378	445
AKC-0280-DX	AKC-0280-BX	AKC-0280-SA AKSB-0280-3-SA	3	190	300	400	510	620	755	890
AKC-0480-DX	AKC-0480-BX	AKC-0480-SA AKSB-0480-SA	4	380	590	810	1020	1240	1510	1780
AKC-0880-DX	AKC-0880-BX	AKC-0880-SA AKSB-0880-SA	6	750	1180	1620	2050	2480	3020	3560
AKC-1480-DX	AKC-1480-BX	AKC-1480-SA AKSB-1480-SA	8	1310	2070	2830	3580	4340	5300	6230
AKC-2280-DX	AKC-2280-BX	AKC-2280-SA AKSB-2280-SA	10	2070	3270	4460	5660	6850	8340	9840

Notes:

1 Two Type A27/80B-SA in parallel required.

Principal Specifications

Model	2002,2003,2004(5)	2104(5)	2206(5)	2208(5)	2312(5)	A15/80
Port Size	1/4",3/8",1/2" NPT	1/2" NPT	3/4" NPT	1" NPT	1 1/2" NPT	2" NPT
Maximum Pressure	250 psig (1)	250 psig (1)	250 psig (1)	250 psig (1)	250 psig (1)	250 psig (1)
Maximum Temperature	170°F (77°C)	170°F (77°C)	130°F (54°C)	130°F (54°C)	130°F (54°C)	130°F (54°C)
Materials of Construction						
Head	Anod. Alum.	Anod. Alum.	Anod. Alum.	Anod. Alum.	Anod. Alum.	Anod. Alum.
Bowl	Anod. Alum.	Anod. Alum.	Steel	Steel	Steel	Steel
Internals	Nylon	Nylon	St. Steel	St. Steel	St. Steel	St. Steel
Seals	Buna-N	Buna-N	Buna-N	Buna-N	Buna-N	Buna-N
Shipping Weight	2 lbs. (0.9 kg)	2.5 lbs. (1 kg)	8 lbs. (3.6 kg)	8 lbs. (3.6 kg)	15 lbs. (6.8 kg)	11 lbs. (5 kg)
Dimensions	3.3"W X 8.5"L (8cm X 22cm)	3.3"W X 11.3"L (8cm X 28cm)	4"W X 13"L (10cm X 33cm)	4"W X 13"L (10cm X 33cm)	5.0"W X 17"L (13cm X 43cm)	6.3"W X 28"L (16cm X 71cm)

Ordering Information

For assistance, call toll-free at 1-800-343-4048 8AM to 5PM Eastern Time

Model	2002,2003,2004(5)	2104(5)	2206(5)	2208(5)	2312(5)	A15/80
Assembly with Grade DX Filter Cartridge	200?-IBI-DX	2104N-IBI-DX	2206N-IBI-DX	2208N-IBI-DX	2312N-IBI-DX	A15/80-DX
Assembly with Grade BX Filter Cartridge	200?-IBI-BX	2104N-IBI-BX	2206N-IBI-BX	2208N-IBI-BX	2312N-IBI-BX	A15/80-BX
Assembly with Grade SA Filter Cartridge & Support Core	200?-OAO-SA	2104N-OAO-SA	2206N-OAO-SA	2208N-OAO-SA	2312N-OAO-SA	A15/80-SA
Differential Pressure Indicator (optional)(2)	Included	Included	Included	Included	Included	Included
Filter Cartridges (3)						
Number Required	1	1	1	1	1	1
Box of 3 (4)	3/100-12-□	3/100-18-□	3/150-19-□	3/150-19-□	3/200-35-□	3/200-80-□
Box of 5 (4)	5/100-12-□	5/100-18-□	5/150-19-□	5/150-19-□	5/200-35-□	5/200-80-□
Box of 10 (4)	100-12-□	100-18-□	150-19-□	150-19-□	200-35-□	200-80-□

Notes:

1 Maximum pressure ratings are for temperatures to 130°F (54°C). Please consult factory for maximum pressure ratings at elevated temperatures.

2 Differential Pressure Indicator is not supplied with assemblies containing Grade SA Cartridges. Maximum pressure rating for 41-082 is 250 psig. The DPI is sensitive in the range of 0-5 psi differential.

3 To order filter cartridges, indicate the grade of filter cartridge by placing the appropriate letter after the ordering number. Examples: 5/100-12-DXE, 100-18-BXE, 150-19-SA.

4 Grades BXE, DXE are available only in boxes of 5 and 10. Grade SA is available in boxes of 3 and 10.

5 Lifetime (20 year) warranty included. Contact your local representative for details.

How to Order the New "2000 Series"

Build your own custom filter assembly using the guideline matrix to the right and specify your model number. Example: 1/2" filter with DPI and Auto Drain with Grade DXE Filter = 2104N-1B1-DX

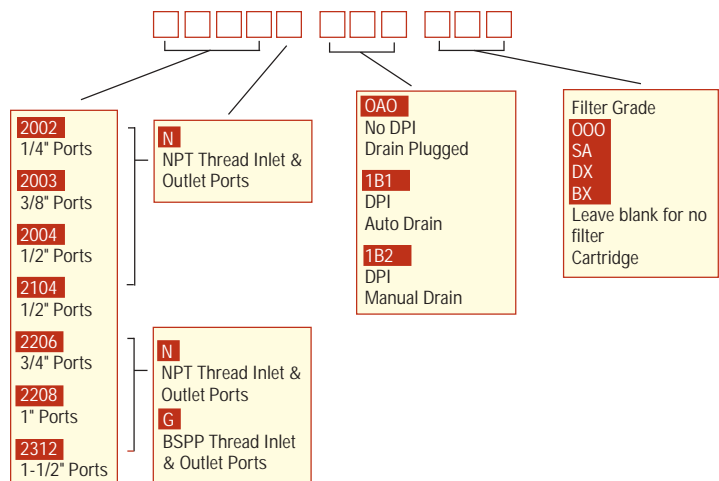

Remove all viable organisms

Full compliance with FDA requirements

High flow rates

USDA accepted for use in federally inspected meat and poultry plants

Balston® Sterile Air Filters

Balston grade SA filter cartridges, rated at 99.9999+% efficiency for 0.1 micron particles, is at least 30 times better than the accepted standard for sterile air filters developed by independent research organizations in the U.S. and U.K. (request Bulletin TI-105A for a detailed discussion on Balston filter efficiency rating procedure, and Bulletin TI-935 for an independent test report on Balston Sterile Air Filters). Balston Sterile Air Filters are in full compliance with the requirements of the FDA.

Here's what one of your colleagues found:

A Balston sterile air filter assembly, consisting of Models A912A-DX, A912A-BX, and A912A-SA was tested at the University of Massachusetts, Department of Food Science and Nutrition, under the direction of Professor David A. Evans, Ph.D.

"This sterile air system produced commercially sterile air and, to the limits of detection, no viable colonies of microorganisms were found".

- Professor David A. Evans, Ph.D.



Model AKC-0280



Model AKC-1480



Principal Specifications

Model	AKC-0280	AKC-0480	AKC-0880	AKC-1480	AKC-2280
Port Size	3" Flange	4" Flange	6" Flange	8" Flange	10" Flange
Maximum Pressure (1)	250 psig	250 psig	200 psig	200 psig	200 psig
Maximum Temperature (2)	230°F (110°C)	230°F (110°C)	250°F (110°C)	250°F (110°C)	250°F (110°C)
Materials of Construction	Carbon steel vessel with 303 Stainless Steel filter tube holders and Buna N seals.				
Closure Type	Flat flanged top with swing bolts and Buna N "O" rings.				
Shipping Weight	132 lbs. (60 kg)	210 lbs. (95 kg)	360 lbs. (163 kg)	590 lbs. (268 kg)	880 lbs. (400 kg)
Dimensions	36"H X 16"W (91cm X 40cm)	36"H X 21"W (91cm X 53cm)	38"H X 25"W (97cm X 64cm)	54"H X 34"W (137cm X 86cm)	56"H X 36"W (142cm X 91cm)
Flange Center Line to Floor Dimension	7.75" (20cm)	6.25" (11cm)	7.5" (19cm)	16.25" (41cm)	17.25" (44cm)

Ordering Information (3)

For assistance, call toll-free at 1-800-343-4048 8AM to 5PM Eastern Time

Model	AKC-0280	AKC-0480	AKC-0880	AKC-1480	AKC-2280
Assembly with Grade DX Filter Cartridge	AKC-0280-DX	AKC-0480-DX	AKC-0880-DX	AKC-1480-DX	AKC-2280-DX
Assembly with Grade BX Filter Cartridge	AKC-0280-BX	AKC-0480-BX	AKC-0880-BX	AKC-1480-BX	AKC-2280-BX
Assembly with Grade SA Filter Cartridge & Support Core	AKC-0280-SA	AKC-0480-SA	AKC-0880-SA	AKC-1480-SA	AKC-2280-SA
Filter Cartridges					
Number Required	2	4	8	14	22
Box of 3 (4)	3/200-80-□	3/200-80-□	3/200-80-□	3/200-80-□	3/200-80-□
Box of 5 (5)	5/200-80-□	5/200-80-□	5/200-80-□	5/200-80-□	5/200-80-□
Box of 10	200-80-□	200-80-□	200-80-□	200-80-□	200-80-□

Notes:

1 Vessel is ASME Section VIII, Division 1 code stamped for rated pressure. All AKC series housings have CRN registration numbers assigned in all Canadian provinces.

2 Maximum operating temperature may be limited by seal material. Consult factory for recommendations at elevated temperatures.

3 Filter assemblies are shipped complete with automatic drain, filter cartridges, and differential pressure indicator.

Automatic Drain

The maximum operating pressure for the Model 20-211 Automatic Drain is 400 psig. Minimum operating pressure is 10 psig.

Differential Pressure Indicator

The maximum operating pressure for the Differential Pressure Indicator Model 41-071 is 250 psig. The DPI is sensitive in the range of 0-5 psi.

The Automatic Drain and Differential Pressure Indicator are not included with assemblies containing SA cartridges.

4 To order filter cartridges, indicate the grade of filter cartridge by placing the appropriate letter after the ordering number. Examples: 5/100-12-DXE, 100-18-BXE, 150-19-SA.

5 Grades BXE, DXE are available in boxes of 5 and 10 only. Grade SA is available in boxes of 3 and 10.

Steam Sterilizable Sterile Air Filters**Remove all viable organisms****In-line steam sterilization****Low pressure drop****Full compliance with FDA requirements****USDA accepted for use in federally inspected meat and poultry plants****Balston® Sterile Air Filters**

Balston grade SA filter cartridges, rated at 99.9999+% efficiency for 0.1 micron particles, is at least 30 times better than the accepted standard for sterile air filters developed by independent research organizations in the U.S. and U.K. (request Bulletin TI-105A for a detailed discussion on Balston filter efficiency rating procedure, and Bulletin TI-935 for an independent test report on Balston Sterile Air Filters). Balston Sterile Air Filters are in full compliance with the requirements of the FDA.

Here's what one of your colleagues found:

A Balston sterile air filter assembly, consisting of Models A912A-DX, A912A-BX, and A912A-SA was tested at the University of Massachusetts, Department of Food Science and Nutrition, under the direction of Professor David A. Evans, Ph.D.

"This sterile air system produced commercially sterile air and, to the limits of detection, no viable colonies of microorganisms were found".

- Professor David A. Evans, Ph.D.



Model A33B-SA



Model A45B-SA



Model A27/35B-SA, A27/80B-SA



Steam Sterilizable Sterile Air Filters

Principal Specifications				
Model	A33B	A45B	A27/35B	A27/80B
Inlet and Outlet Ports (1)	1/4" NPT	1/2" NPT	1" NPT	1" NPT
Drain Port (2)	1/8" NPT	1/8" NPT	1/4" NPT	1/4" NPT
Materials of Construction				
Head	316SS	316SS	316SS	316SS
Bowl	316SS	316SS	316SS	316SS
Internals	316SS	316SS	316SS	316SS
Seals (3)	Viton	Viton	Viton	Viton
Maximum Temperature	400°F (204°C)	400°F (204°C)	400°F (204°C)	400°F (204°C)
Maximum Pressure (4)	425 psig	250 psig	800 psig	800 psig
Maximum Steam Pressure for Sterilization	60 psig	60 psig	60 psig	60 psig
Shipping Weight	3 lbs. (1 kg)	5 lbs. (2 kg)	16 lbs. (7 kg)	20 lbs. (9 kg)
Dimensions	2.6"Dia X 4.9"L (7cm X 12cm)	2.6"Dia. X 8.4"L (7cm X 21cm)	4.0"Dia. X 16"L (10cm X 40cm)	4.0"Dia. X 27"L (10cm X 69cm)

Ordering Information

For assistance, call toll-free at 1-800-343-4048 8AM to 5PM Eastern Time

Model	A33B	A45B	A27/35B	A27/80B
Assembly with Grade SA Filter Cartridge	A33B-SA	A45B-SA	A27/35B-SA	A27/80B-SA
Filter Cartridges:				
Number Required	1	1	1	1
Box of 3	3/100-12-SA	3/100-25-SA	3/200-35-SA	3/200-80-SA
Box of 10	100-12-SA	100-25-SA	200-35-SA	200-80-SA

Notes:

1 Adaptors are available which convert threaded ports to sanitary type clamp connections.

Ordering Information:

Part # 73803 1" NPT x 1" Sanitary

Part # 73804 1 1/2" NPT x 1 1/2" Sanitary

Part # 73805 2" NPT x 2" Sanitary

2 Condensate drain valve required. Supplied by customer.

3 Constructed of food grade Viton.

4 Maximum pressure ratings are for temperatures to 130°F (54°C). Please consult factory for maximum pressure ratings at elevated temperatures.

Steam Sterilizable Sterile Air Filters

Remove all viable organisms

In-line steam sterilization

High flow rates

Full compliance with FDA requirements

USDA accepted for use in federally inspected meat and poultry plants

Balston® Sterile Air Filters

Balston grade SA filter cartridges, rated at 99.9999+% efficiency for 0.1 micron particles, is at least 30 times better than the accepted standard for sterile air filters developed by independent research organizations in the U.S. and U.K. (request Bulletin TI-105A for a detailed discussion on Balston filter efficiency rating procedure, and Bulletin TI-935 for an independent test report on Balston Sterile Air Filters). Balston Sterile Air Filters are in full compliance with the requirements of the FDA.

Here's what one of your colleagues found:

A Balston sterile air filter assembly, consisting of Models A912A-DX, A912A-BX, and A912A-SA was tested at the University of Massachusetts, Department of Food Science and Nutrition, under the direction of Professor David A. Evans, Ph.D.

"This sterile air system produced commercially sterile air and, to the limits of detection, no viable colonies of microorganisms were found".

- Professor David A. Evans, Ph.D.



Model AKSB-0280-3-SA



Model AKSB-1480-SA



Steam Sterilizable Sterile Air Filters**Principal Specifications**

Model	AKSB-0280-2-SA	AKSB-0280-3-SA	AKSB-0480-SA	AKSB-0880-SA	AKSB-1480-SA	AKSB-2280-SA
Port Size	2" Flange	3" Flange	4" Flange	6" Flange	8" Flange	10" Flange
Materials of Construction	316SS	316SS	316SS	316SS	316SS	316SS
Seals (1)	Viton	Viton	Viton	Viton	Viton	Viton
Maximum Pressure (2)	200 psig	200 psig	200 psig	200 psig	200 psig	200 psig
Maximum Temperature	200°F (93°C)	200°F (93°C)	200°F (93°C)	200°F (93°C)	200°F (93°C)	200°F (93°C)
Maximum Steam Pressure for Sterilization	60 psig	60 psig	60 psig	60 psig	60 psig	60 psig
Shipping Weight	140 lbs. (64 kg)	140 lbs. (64 kg)	210 lbs. (95 kg)	360 lbs. (163 kg)	590 lbs. (268 kg)	880 lbs. (400 kg)
Dimensions	16"W X 36"L (41cm X 91cm)	16"W X 36"L (41cm X 91cm)	20"W X 36"L (53cm X 91cm)	25"W X 38"L (64cm X 97cm)	34"W X 54"L (86cm X 137cm)	36"W X 56"L (91cm X 142cm)

Ordering Information

For assistance, call toll-free at 1-800-343-4048 8AM to 5PM Eastern Time

Model	AKSB-0280-2	AKSB-0280-3	AKSB-0480	AKSB-0880	AKSB-1480	AKSB-2280
Assembly with Grade SA Filter Cartridge	AKSB-0280-2-SA	AKSB-0280-3-SA	AKSB-0480-SA	AKSB-0880-SA	AKSB-1480-SA	AKSB-0280-SA
Filter Cartridges:						
Box of 3	3/200-80-SA	3/200-80-SA	3/200-80-SA	3/200-80-SA	3/200-80-SA	3/200-80-SA
Box of 10	200-80-SA	200-80-SA	200-80-SA	200-80-SA	200-80-SA	200-80-SA
Number per housing	2	2	4	8	14	22

Notes:

- 1 Constructed of food grade Viton.
- 2 Vessel is ASME Section VIII Division 1 Code stamped for rated pressure.

Nitrogen Generation Systems



Membrane and PSA technologies available

Lower cost... eliminates the need for costly gas cylinders

Eliminates unexpected shutdowns due to a "bad" or empty cylinder

Hassle-free, easy to install and operate

Compact...frees up valuable floor space

Safe and reliable

Balston Nitrogen Generation Systems

Balston offers both membrane and PSA technology. Balston Membrane Nitrogen Generators produce up to 99.5% pure, commercially sterile nitrogen at dewpoints to -58°F (-50°C) from a compressed air supply. All Membrane Nitrogen Generators include a 0.01 micron membrane filter which ensures the nitrogen is completely free of suspended impurities.

Balston Monobed and Dualbed PSA Nitrogen Generators produce up to 99.95% pure, compressed nitrogen at dewpoints to -70°F (-21°C) from a compressed air supply. The generators are designed to continually transform standard compressed air into nitrogen at safe, regulated pressures without operator attention.



Balston
Membrane Nitrogen Generator

Lower cost...eliminates the need for costly gas cylinders

Complete package with prefilters, carbon filter, and membrane filter

Compact - frees up valuable floor space

Eliminates unexpected shutdowns due to a "bad" or empty cylinder

Hassle-free, easy to install, easy to operate

Safe and reliable

No electrical line required

Applications

Purging or testing of tanks and vessels	Analytical equipment purge
Solvent blanketing	Carburizing, hardening, sintering, annealing
Food processing and packaging	Packaging
Storage of perishables	Chemical transferring
Electronic component manufacture and storage	Sparging and mixing

Advantages of Balston® Nitrogen Generators

Balston Membrane Nitrogen Generators produce up to 98% pure, commercially sterile nitrogen at dewpoints to -58°F (-50°C) from a compressed air supply. All Membrane Nitrogen Generators include a 0.01 micron membrane filter which ensures the nitrogen is completely free of suspended impurities. For applications requiring monitoring and controlling, models HFXO Series and all Nitrosorce NS Series include an oxygen monitor which offers LED readouts and remote alarm or chart recorder capabilities. An audible alarm signals high or low oxygen concentrations (determined by the application). The oxygen monitor is supplied with alarm relay outputs which may be used to signal a remote alarm, open a backup supply or the process stream, or close the process flow.



**HFX Series
High Flow Nitrogen
Membrane Generator**



**Nitrosorce Series
Modular Nitrogen
Membrane Generator**



Proven Technology

Balston Membrane Nitrogen Generators produce up to 98% pure, commercially sterile nitrogen at dewpoints to -58°F (-50°C) from a compressed air supply. All Membrane Nitrogen Generators include a 0.01 micron membrane filter which ensures the nitrogen is completely free of suspended impurities. For applications requiring monitoring and controlling, Parker Hannifin offers systems which include oxygen monitors.

Balston Nitrogen Generators are one of the most efficient membrane systems available with higher recovery rates and lower operating costs than many other membrane systems.

Balston Nitrogen Generators utilize proprietary membrane separation technology. The membrane divides the air into two streams: one is 95%-98% pure nitrogen, and the other is oxygen-rich with carbon dioxide and other trace gases.

The generator separates air into its component gases by passing inexpensive, conventional compressed air through bundles of individual hollow fiber, semi-permeable membranes. Each fiber has a perfectly circular cross section and a uniform bore through its center. Because the fibers are so small, a great many can be packed into a limited space, providing an extremely large membrane surface area that can produce a relatively high volume product stream.

Compressed air is introduced to the center of the fibers at one end of the module and contacts the membrane as it flows through the fiber bores. While oxygen, water vapor and other trace gases permeate the membrane fiber and are discharged through a permeate port, the nitrogen is contained within the hollow fiber membrane, and flows through the outlet port of the module.

Water vapor also permeates through the membrane; therefore, the nitrogen product gas is very dry.

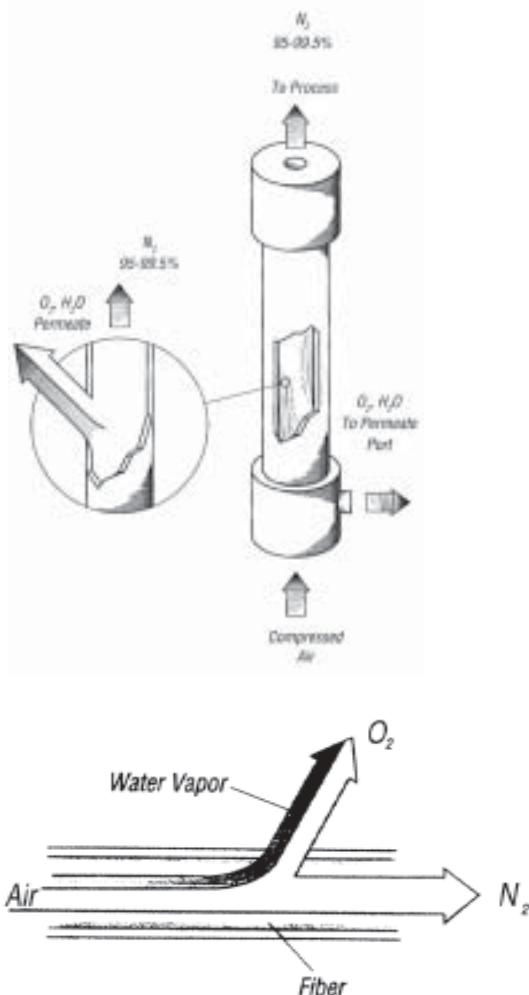

While "fast gases" like oxygen, carbon dioxide, and water vapor quickly permeate the membrane, most of the nitrogen flows along the membrane fiber as a separate product stream.





Advantages

- Lower cost...eliminates the need for costly gas cylinders
- Complete package with prefilters, carbon filter, and membrane filter
- Compact - frees up valuable floor space
- Eliminates unexpected shutdowns due to a "bad" or empty cylinder
- Hassle-free, easy to install, easy to operate
- Safe and reliable
- No electrical line required⁽¹⁾

Custom Systems Available

- Flow rates to 9200 SCFH
- Delivery pressures to customer's specifications
- Skid mounted systems with compressor, receiving tank and controls are available

Savings And Convenience

The Balston Membrane Nitrogen Generators completely eliminate the inconvenience and the high costs of nitrogen Dewars and cylinders. There is no need to depend on outside vendors for nitrogen gas supplies. The hassles of changing dangerous, high pressure cylinders and interruption of gas supplies are completely eliminated. The Balston Systems offer long term cost stability by eliminating uncontrollable vendor price increases, contract negotiation, long term commitments and tank rentals. Once the Generator is installed, a continuous nitrogen supply of consistent purity is available within minutes from start-up.

The Balston Nitrogen Generators are complete systems ready to operate as delivered with carefully matched components engineered for easy installation, operation and long term reliability. The generators are free-standing and housed in an attractive cabinet. Standard features include: high efficiency coalescing prefilters with automatic drains, an activated carbon filter, and a 0.01 micron membrane final filter.

Installation consists of simply connecting a standard compressed air line to the inlet and connecting the outlet to a nitrogen line. The membrane systems offer the advantages of no moving parts and no electrical requirements.⁽¹⁾

There is no complicated operating procedure to learn or labor intensive monitoring involved. Simply select the purity your process requires, set the flow and pressure, and within minutes high purity, dry nitrogen is available for use!

Once the system is operating, it requires little monitoring. The only maintenance involves changing the coalescing filter cartridges and activated carbon filter periodically. This is a simple ten minute procedure.

The Balston HFXO Series include an oxygen monitor which offers LED readouts and remote alarm or chart recorder capabilities. An audible alarm signals high or low oxygen concentrations (determined by the application). The oxygen monitor is supplied with alarm relay outputs which may be used to signal a remote alarm, open a backup supply or the process stream, or close the process flow.

Notes:

- 1 No electrical power required unless used with an accessory such as an oxygen monitor.

Flow Rates (SCFH) @ 100 psig @ 68°F					Pressure Correction Factors (at Indicated Operating Pressure (PSIG))									
Model	98%	97%	96%	95%	58	73	87	101	116	130	145	160	174	190
HFX Series Nitrogen Generators														
HFX-1NA	15.9	25.8	32.8	40.3	.52	.65	.86	1	1.15	1.35	1.44	---	---	---
HFX-3NA	70	95	120	148	.54	.68	.85	1	1.14	1.3	1.43	---	---	---
HFX-5NA	131	176	229	279	.52	.65	.85	1	1.14	1.34	1.43	---	---	---
HFX-7NA	209	283	360	452	.53	.66	.86	1	1.14	1.32	1.43	---	---	---
HFX-9NA	330	452	600	752	.44	.65	.85	1	1.1	1.3	1.4	---	---	---
HFX-11NA	572	780	992	1201	.44	.65	.85	1	1.2	1.4	1.6	---	---	---
Nitrosorce Series Nitrogen Generators														
Main-Unit 159.003552	570.4	780.5	990.6	1200.7	.35	.51	.76	1	1.2	1.4	1.6	1.9	2.1	2.4
NS-1	1140.7	1561.0	1981.2	2401.5	.35	.51	.76	1	1.2	1.4	1.6	1.9	2.1	2.4
NS-2	1711.1	2341.5	2971.8	3602.2	.35	.51	.76	1	1.2	1.4	1.6	1.9	2.1	2.4
NS-3	2281.4	3121.9	3962.5	4803.0	.35	.51	.76	1	1.2	1.4	1.6	1.9	2.1	2.4
NS-4	2851.8	3902.4	4953.1	6003.7	.35	.51	.76	1	1.2	1.4	1.6	1.9	2.1	2.4
NS-5	3422.1	4682.9	5943.7	7204.5	.35	.51	.76	1	1.2	1.4	1.6	1.9	2.1	2.4

Principal Specifications - HFX Series Membrane Nitrogen Generators Models HFX1, HFX-3, HFX-5, HFX-7, HFX-9, HFX-11				
Model Number	HFX-1, HFX0-1	HFX-3, HFX0-3	HFX-5, HFX0-5	HFX-7, HFX0-7, HFX-9, HFX0-9, HFX-11, HFX0-11
Atmospheric Dewpoint	-58°F (-50°C)	-58°F (-50°C)	-58°F (-50°C)	-58°F (-50°C)
Commercially Sterile	Yes	Yes	Yes	Yes
Particles > 0.01 micron	None	None	None	None
Suspended Liquids	None	None	None	None
Min/Max Operating Press.(1)	60 psig/145 psig	60 psig/145 psig	60 psig/145 psig	60 psig/145 psig
Max. Press. Drop (at 95% N ₂ , 125 psig)	10 psig	10 psig	10 psig	10 psig
Recommended Ambient Operating Temperature	60°F/110°F (16°C/43°C)	77°F (25°C)	77°F (25°C)	- 77°F (25°C)
Min/Max Inlet Air Temp.	60°F/110°F (2°C/40°C)	40°F/140°F (2°C/40°C)	40°F/140°F (4°C/60°C)	40°F/140°F (4°C/60°C)
Recommended Inlet Air Temperature	68°F (20°C)	77°F (25°C)	77°F (25°C)	77°F (25°C)
Electrical Requirements (2)	None (2)	None (2)	None (2)	None (2)
Dimensions	16.3"h x 12.8"w x 7.5"d (41/4cmx32/5cmx19.1cm)	16"w x 16"d x 50"h (41cmX25cmX91cm)	16"w x 16"d x 50"h (41cmX25cmX91cm)	24"w x 20"d x 69"h (61cmX51cmX175cm)
Shipping Wt.	38 lbs. (17.3 kg)	75 lbs. (34 kg)	106 lbs. (114 kg)	250 lbs. (114 kg)

Notes:

1 Maximum operating pressure in Europe is 8 barg.

2 No electrical power required unless used with an electrical accessory, e.g., an oxygen analyzer.

Ordering Information - Models HFX1, HFX-3, HFX-5, HFX-9, HFX-11					
For assistance, call toll-free at 1-800-343-4048 8AM to 5PM Eastern Time					
Model	Replacement Filter Cartridges, 1st stage	Replacement Filter Cartridges, 2nd stage	Replacement Filter Cartridges, 3rd Stage	Final Membrane Filter	Activated Carbon Filter
HFX-1, HFX0-1 (with O2 monitor)	100-12-DXE	100-12-BXE	---	GS-100-12-95	7825-08-000
HFX-3, HFX0-3 (with O2 monitor)	100-12-DXE	100-12-BXE	---	GS-100-12-95	75620
HFX-5, HFX0-5 (with O2 monitor)	100-12-DXE	100-12-BXE	---	GS-100-12-95	75620
HFX-7, HFX0-7 (with O2 monitor)	100-18-DXE	100-18-BXE	100-25-BXE	GS-100-25-95	75303
HFX-9, HFX0-9 (with O2 monitor)	100-18-DXE	100-18-BXE	100-25-BXE	GS-100-25-95	75303
HFX-11, HFX0-11 (with O2 monitor)	100-18-DXE	100-18-BXE	100-25-BXE	GS-100-25-95	75303

Principal Specifications - Nitrosource Series Membrane Nitrogen Generators - Models NS-1, NS-2, NS-3

Model Number	NS-1	NS-2	NS-3
Atmospheric Dewpoint	-58°F (-50°C)	-58°F (-50°C)	-58°F (-50°C)
Commercially Sterile	Yes	Yes	Yes
Particles > 0.01 micron	None	None	None
Suspended Liquids	None	None	None
Min/Max Operating Pressure (1)	60 psig/145 psig	60 psig/145 psig	60 psig/145 psig
Max. Press. Drop (at 95% N ₂ , 125 psig)	15 psig	15 psig	15 psig
Recommended Ambient Operating Temp.	70°F (21°C)	70°F (21°C)	70°F (21°C)
Min/Max Inlet Air Temp.	50°F/104°F (10°C/40°C)	50°F/104°F (10°C/40°C)	50°F/104°F (10°C/40°C)
Recommended Inlet Air Temp.	70°F (21°C)	70°F (21°C)	70°F (21°C)
Electrical Requirements	90-250 VAC 50-60 Hz	90-250 VAC 50-60 Hz	90-250 VAC 50-60 Hz
Dimensions	29"w x 31"d x 76"h (74cmX51cmX193cm)	29"w x 42"d x 76"h (74cmX79cmX193cm)	29"w x 53"d x 76"h (74cmX107cmX193cm)
Shipping Wt.	660 lbs.	870 lbs.	1290 lbs.

Principal Specifications - Nitrosource Series Membrane Nitrogen Generators - Models NS-4, NS-5, Main Unit

Model Number	NS-4	NS-5	Main Unit
Atmospheric Dewpoint	-58°F (-50°C)	-58°F (-50°C)	-58°F (-50°C)
Commercially Sterile	Yes	Yes	Yes
Particles > 0.01 micron	None	None	None
Suspended Liquids	None	None	None
Min/Max Operating Pressure (1)	60 psig/145 psig	60 psig/145 psig	60 psig/145 psig
Max. Press. Drop (at 95% N ₂ , 125 psig)	15 psig	15 psig	15 psig
Recommended Ambient Operating Temp.	70°F (21°C)	70°F (21°C)	70°F (21°C)
Min/Max Inlet Air Temp.	50°F/104°F (10°C/40°C)	50°F/104°F (10°C/40°C)	50°F/104°F (10°C/40°C)
Recommended Inlet Air Temp.	70°F (21°C)	70°F (21°C)	70°F (21°C)
Electrical Requirements (2)	90-250 VAC 50-60 Hz	90-250 VAC 50-60 Hz	90-250 VAC 50-60 Hz
Dimensions	29"w x 64"d x 76"h (74cmX51cmX193cm)	29"w x 75"d x 76"h (74cmX79cmX193cm)	29"w x 20"d x 76"h (74cmX107cmX193cm)
Shipping Wt.	1500 lbs.	1710 lbs.	450 lbs.

Notes:

1 For temperatures less than 68°F (20°C) or pressures less than 60 psig, consult factory for flows.

Ordering Information - All Nitrosource Series Models

For assistance, call toll-free at 1-800-343-4048 8AM to 5PM Eastern Time

Description	Model #	Maintenance Kit #	O2 Sensor
Main Unit	159.003552	159.003569	2284
Sub Unit	159.003553	159.003570	
Main Unit	NS-1	159.003569	2284
Sub Unit		159.003570	
Main Unit	NS-2	159.003569	2284
2 Sub Unit		159.003570x2	
Main Unit	NS-3	159.003569	2284
3 Sub Unit		159.003570x3	
Main Unit	NS-4	159.003569	2284
4 Sub Unit		159.003570x4	
Main Unit	NS-5	159.003569	2284
5 Sub Unit		159.003570x5	



Lower cost...eliminates the need for costly gas cylinders

Complete package with prefilters, final filters, and receiving tank

Compact - frees up valuable floor space

Eliminates unexpected shutdowns due to a "bad" or empty cylinder

Hassle-free, easy to install, easy to operate

Safe and reliable

Proven Technology

Balston Monobed and Dual Bed Nitrogen Generators produce up to 99.95% pure, compressed nitrogen at dewpoints to -70°F (-21°C) from nearly any compressed air supply. The generators are designed to continually transform standard compressed air into nitrogen at safe, regulated pressures without operator attention.

How the Technology Works

Balston PSA Nitrogen Generators utilize a combination of filtration and pressure swing adsorption technologies. High efficiency prefiltration pretreats the compressed air to remove all contaminants down to 0.1 micron. Air entering the generator consists of 21% oxygen and 78% nitrogen. The gas separation process preferentially adsorbs oxygen over nitrogen using carbon molecular sieve (CMS). At high pressures the CMS has a greater affinity for oxygen, carbon dioxide, and water vapor than it does at low pressures. By raising and lowering the pressure within the CMS bed, all contaminants are captured and released, leaving the CMS unchanged. This process allows the nitrogen to pass through as a product gas at pressure. The depressurization phase of the CMS releases the absorbed oxygen and other contaminant gases to the atmosphere.

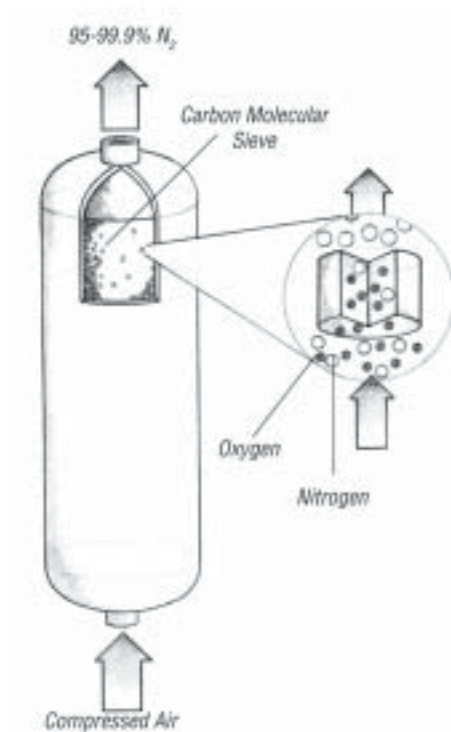

Pressure swing adsorption gas separation process preferentially adsorbs oxygen over nitrogen using carbon molecular sieve (CMS).



Applications

Solder Reflow Ovens
 Food Processing and Packaging
 Electronic Component Storage and Manufacture
 Heat Treating
 Degassing Aluminum
 Plastic Extrusion and Molding
 Gas Assist
 Laser Cutting

Savings and Convenience

The Balston PSA Nitrogen Generators completely eliminate the inconvenience and the high costs of nitrogen Dewars, bulk nitrogen supplies, and cylinders. There is no need to depend on outside vendors for your nitrogen gas supplies. The hassles of changing dangerous, high pressure cylinders, and interruption of gas supplies are completely eliminated. The Balston PSA Nitrogen Generators offer long term cost stability eliminating uncontrollable vendor price increases, contract negotiations, long term commitments, and tank rentals. Once the Generator is installed, a continuous nitrogen supply of consistent purity is available within minutes from start-up.

Easy to Operate and Maintain

Installation consists of simply connecting a standard compressed air line to the inlet and connecting the outlet to a nitrogen line. Plug the electrical cord into a wall outlet, and the unit is ready for trouble-free operation. This system is designed to operate 24 hours per day, 7 days per week.

Once the system is operating, it requires little monitoring. The only maintenance involves changing the coalescing prefilter cartridges and final sterile air filter periodically. The PSA towers do not require any maintenance.

An oxygen monitor to measure the oxygen concentration of the nitrogen stream is available as an option. An audible alarm signals high or low oxygen concentrations (determined by the application). The oxygen analyzer is supplied with alarm relay outputs which may be used to signal a remote alarm, open a backup supply or the process stream, or close the process flow for protection of downstream equipment or processes.

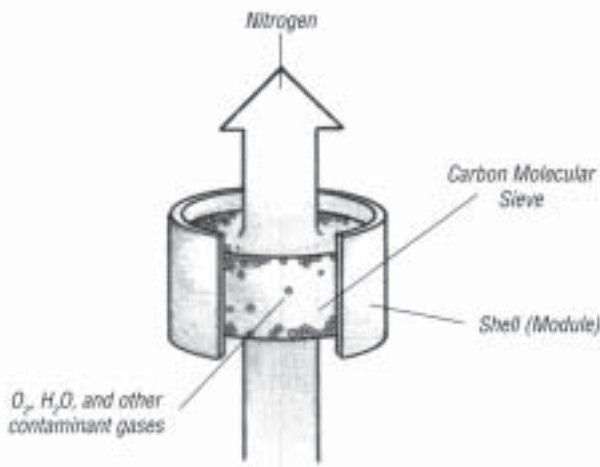

Principal Specifications - Models MB-200, MB-400, MB-600, MB-800, MB-1000					
Model Number	MB-200	MB-400	MB-600	MB-800	MB-1000
Atmospheric Dewpoint	-70°F (-21°C) →				
Commercially Sterile	Yes →				
Particles > 0.01 micron	None →				
Suspended Liquids	None →				
Recommended Inlet Pressure	110 psig (7.6 barg) →				
Min/Max Ambient Temperature	40°F/95°F (4°C/35°C) →				
Avg. Max Air Consumption(@95%)	1050 scfh	2300 scfh	3275 scfh	4500 scfh	5277 scfh
Inlet Port Size	3/4" NPT (female)	3/4" NPT (female)	1 1/2" NPT (female)	1 1/2" NPT (female)	1 1/2" NPT (female)
Outlet Port Size	1/4" NPT (female)	1/4" NPT (female)	1/2" NPT (female)	1/2" NPT (female)	1" NPT (female)
Electrical Requirements	120VAC/60 Hz →				
Dimensions (214cmx153cmx290cm)	56"w x 36"d x 87"h (143cmx92cmx214cm)	56"w x 42"d x 89"h (143cmx107cmx226cm)	78"w x 48"d x 102"h	78"w x 48"d x 103"h (198cmx122cmx260cm)	84"w x 60"d x 114"h (198cmx122cmx262cm)
Shipping Wt.	1100 lbs. (500 kg)	1800 lbs. (818 kg)	2100lbs. (955 kg)	2300lbs. (1045 kg)	4500 lbs. (2045 kg)

Ordering Information - Models MB-200, MB-400, MB-600, MB-800, MB-1000					
For assistance, call toll-free at 1-800-343-4048 8AM to 5PM Eastern Time					
Model	MB-200	MB-400	MB-600	MB-800	MB-1000
Prefilter Cartridges, 1st Stage	150-19-DXE	150-19-DXE	150-19-DXE	200-35-DXE	200-80-DXE
Prefilter Cartridges, 2nd Stage	150-19-BXE	150-19-BXE	150-19-BXE	200-35-BXE	200-80-BXE
Final Sterile Air Filter	100-25-SA	100-25-SA	100-25-SA	150-19-SA	150-19-SA
Oxygen monitor (Opt.)	72-730 →				
Back Pressure Controller (Opt.) (1)	72-460 →				

Nitrogen Purity Flow Chart - Models MB-200, MB-400, MB-600, MB-800, MB-1000

Maximum Outlet Pressure (psig)					
Purity	MB-200	MB-400	MB-600	MB-800	MB-1000
95	30	30	30	30	30
96	40	40	40	40	40
97	50	50	50	50	50
98	60	60	65	60	60
99	65	65	70	65	65
99.5	70	70	70	70	70
99.9	75	75	80	75	75
99.95	80	80	80	80	80

Flow Rate (SCFH)					
Purity	MB-200	MB-400	MB-600	MB-800	MB-1000
95	433	880	1310	1760	2162
96	400	815	1200	1630	2000
97	361	735	1090	1470	1802
98	311	630	940	1260	1555
99	241	490	730	980	1205
99.5	200	400	600	800	1000
99.9	135	245	374	490	619
99.95	98	200	269	361	451

Notes

1 The 72-460 is an optional accessory which will maintain a constant pressure drop across the flow control valve, thereby providing a constant nitrogen purity.



Principal Specifications

Dual Bed Nitrogen Generator	DB-1200	DB-1600	DB-1900
Atmospheric Dewpoint	-70°F (-21°C)	-70°F (-21°C)	-70°F (-21°C)
Particles > .1 micron	None	None	None
Suspended Liquids	None	None	None
Recommended Inlet Pressure	110 psig (7.6 barg)	110 psig (7.6 barg)	110 psig (7.6 barg)
Min/Max Ambient Temperature	40°F/95°F (4°C/35°C)	40°F/95°F (4°C/35°C)	40°F/95°F (4°C/35°C)
Avg. Max Air Consumption (@95%)	100 scfm	135 scfm	159 scfm
Inlet Port Size	1-1/2" Flange 150# Rated	1-1/2" Flange 150# Rated	2" Flange 150# Rated
Outlet Port Size	1" Flange 150# Rated	1" Flange 150# Rated	1-1/2" Flange 150# Rated
Electrical Requirements	120VAC/60 Hz	120VAC/60 Hz	120VAC/60 Hz
Dimensions	84"w x 60"d x 102"h (214cm x 153cm x 259cm)	84"w x 60"d x 123"h (214cm x 153cm x 313cm)	96"w x 72"d x 108"h (244cm x 183cm x 275cm)
Shipping Wt.	3,800 lbs. (1,724 kg)	3,800 lbs. (1,724 kg)	3,800 lbs. (1,724 kg)

How To Order

For assistance, call toll-free at 1-800-343-4048 8AM to 5PM Eastern Time

Dual Bed Nitrogen Generator	DB-1200	DB-1600	DB-1900
Prefilter Cartridges, 1st Stage	200-35-DX	200-35-DX	200-80-DX
Prefilter Cartridges, 2nd Stage	200-35-BX	200-35-BX	200-80-BX
Additional Prefilter Cartridges	200-35-DX	200-35-DX	200-80-DX
Final Air Filter	100-18-DX	150-19-DX	150-19-DX
Oxygen Monitor	72-730 (Standard) or 3290 (Optional: High Purity)	72-730 (Standard) or 3290 (Optional: High Purity)	72-730 (Standard) or 3290 (Optional: High Purity)

Nitrogen Purity Flow Chart

Purity %N ₂	Maximum Outlet Pressure (psig)		
	DB-1200	DB-1600	DB-1900
95	80	80	80
97	80	80	80
98	80	80	80
99	80	80	80
99.5	80	80	80
99.9	80	80	80
99.95	80	80	80
99.99	80	80	80

Purity %N ₂	Flow Rate (SCFH)		
	DB-1200	DB-1600	DB-1900
95	2,850	3,845	4,516
97	2,200	2,975	3,394
98	1,894	2,555	3,000
99	1,490	2,010	2,360
99.5	1,200	1,600	1,900
99.9	736	992	1,178
99.95	532	714	852
99.99	284	378	452

Principal Specifications

Dual Bed Nitrogen Generator	DB-2500	DB-4000
Atmospheric Dewpoint	-70°F (-21°C)	-70°F (-21°C)
Particles > .1 micron	None	None
Suspended Liquids	None	None
Recommended Inlet Pressure	110 psig (7.6 barg)	110 psig (7.6 barg)
Min/Max Ambient Temperature	40°F/95°F (4°C/35°C)	40°F/95°F (4°C/35°C)
Avg. Max Air Consumption (@95%)	212 scfm	334 scfm
Inlet Port Size	3" Flange 150# Rated	3" Flange 150# Rated
Outlet Port Size	1-1/2" Flange 150# Rated	1-1/2" Flange 150# Rated
Electrical Requirements	120VAC/60 Hz	120VAC/60 Hz
Dimensions	96"w x 72"d x 132"h (244cm x 183cm x 336cm)	108"w x 72"d x 138"h (275cm x 183cm x 351cm)
Shipping Wt.	4,300 lbs. (1,951 kg)	5,300 lbs. (2,404 kg)

How To Order

For assistance, call toll-free at 1-800-343-4048 8AM to 5PM Eastern Time

Dual Bed Nitrogen Generator	DB-2500	DB-4000
Prefilter Cartridges, 1st Stage	200-80-DX	200-80-DX
Prefilter Cartridges, 2nd Stage	200-80-BX	200-80-BX
Additional Prefilter Cartridges	200-80-DX	200-80-DX
Final Air Filter	200-35-DX	200-35-DX
Oxygen Monitor	72-730 (Standard) or 3290 (Optional: High Purity)	72-730 (Standard) or 3290 (Optional: High Purity)

Nitrogen Purity Flow Chart

Maximum Outlet Pressure (psig)		
Purity %N ₂	DB-2500	DB-4000
95	80	80
97	80	80
98	80	80
99	80	80
99.5	80	80
99.9	80	80
99.95	80	80
99.99	80	80

Flow Rate (SCFH)		
Purity %N ₂	DB-2500	DB-4000
95	6,022	9,618
97	4,659	7,442
98	4,000	6,388
99	3,148	5,028
99.5	2,500	4,000
99.9	1,571	2,480
99.95	1,136	1,769
99.99	602	943



Application Notes

Compressed Air Dryers



Unattended 24 hour operation

Compact

Membrane and PSA technologies available

Silent operation

No desiccant to change

Easy to install and operate

Balston Membrane and PSA Air Dryers

Balston offers both membrane and PSA technology. Balston Membrane Air Dryers combine superior coalescing technology with a proven, innovative membrane system to supply clean, dry compressed air with dewpoints as low as -40°F (-40°C)

Balston PSA Compressed Air Dryers will reduce the dewpoint of compressed air to -100°F (-73°C). Each dryer is delivered complete and ready for easy installation.



Balston
Membrane Air
Dryers

Applications

Low dewpoint instrument air
Pneumatic equipment
Pressurizing electronic cabinets
Analytical instrumentation
Prevention of freeze-ups
Dry air for hazardous areas
General laboratory air supply

- "We have not had one shutdown due to freeze-ups since the Balston Membrane Dryer was installed."

Peter Vogt
International Filler Corp.

Offer a reliable, efficient, and economical alternative to pressure swing and refrigerant dryer technologies

Require no electricity thus lowering operating costs

Dewpoints as low as -40°F (-40°C) prevent freeze-ups

Explosion proof

Silent operation

No desiccant to change

Models 76-01, 76-02, 76-10, 76-20, 76-40, and 76-100-4050

Balston Membrane Air Dryers combine a superior coalescing technology with a proven, innovative membrane system to supply clean, dry compressed air with dewpoints as low as -40°F (-40°C). The Balston Membrane Dryers are available in 6 different models which can deliver compressed air at flow rates up to 100 SCFM with a -40°F (-40°C) dewpoint. The Balston Membrane Air Dryers are engineered for easy installation, operation, and long term reliability. The dryers incorporate high efficiency coalescing filtration and the highest efficiency membrane available to provide low cost operation and minimal maintenance.

State-of-the-Art Membrane Technology

Water vapor from the compressed air supply passes through the hollow fibers of the membrane. At the same time, a small portion of the dry air product is redirected along the length of the fibers to sweep out the water vapor laden air which has permeated the membrane. The moisture-laden sweep gas is then vented to the atmosphere, and clean, dry air is supplied to the application. The drying power of the membrane is controlled by varying the compressed air flow rate and pressure. The Balston Membrane Air Dryer is designed to operate continuously, 24 hours per day, 7 days per week. The only maintenance required is changing the prefilter cartridge once a year. This annual maintenance takes approximately 5 minutes.

Membrane Air Dryer - Principle of Operation

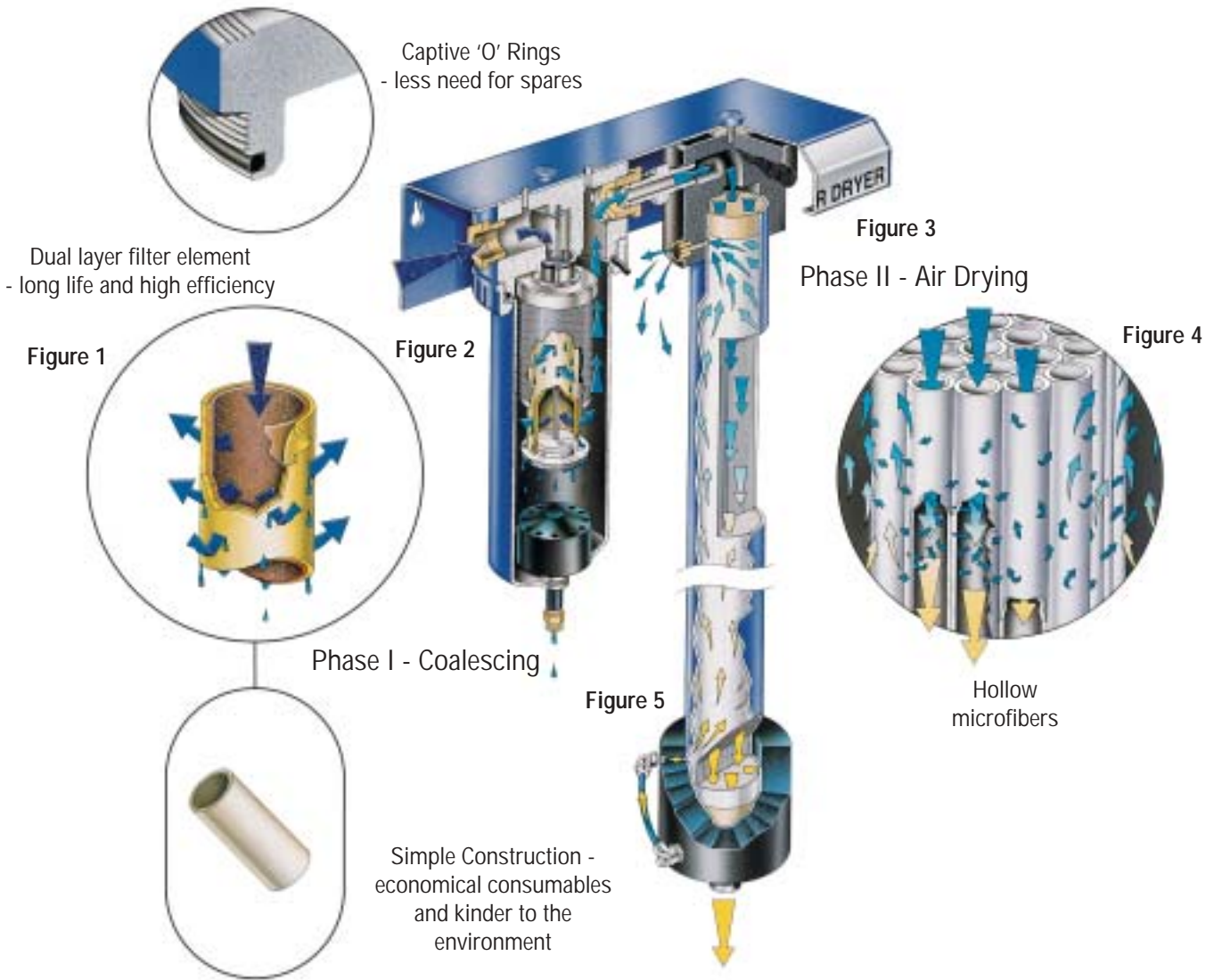

Phase I - Coalescing Filtration

Prior to entering the membrane drying module, the compressed air passes through a high efficiency coalescing filter to remove oil and water droplets and particulate contamination with an efficiency of 99.99% at 0.01 micron. The liquids removed by filter cartridge continuously drip from the filter cartridge into the bottom of the housing, where they are automatically emptied by an autodrain assembly (see Fig. 1 and Fig. 2). The air leaving the prefilter, therefore, is laden only with water vapor, which will be removed in the membrane module.

Phase II - Drying

The water vapor in the compressed air is removed by the principle of selective permeation through a membrane (see Fig. 3). The membrane module consists of bundles of hollow membrane fibers (see Fig. 4), each permeable only to water vapor. As the compressed air passes through the center of these fibers, water vapor permeates through the walls of the fiber, and dry air exits from the other end of the fiber. A small portion of the dry air (regeneration flow) is redirected along the length of the membrane fiber to carry away the moisture-laden air which surrounds the membrane fibers. The remainder of the dry air is piped to the application.



Model 76-01

Model 76-02

Model 76-10

Model 76-20

Model 76-40

Model 76-100-4050

Flow Rates		Outlet Flow (SCFM) at Indicated Operating Pressure (psig) for -40°F (-40°C) Pressure Dewpoint				
Pressure Dewpoint	60 psig -40°F(-40°C)	80 psig -40°F(-40°C)	100 psig -40°F(-40°C)	120 psig -40°F(-40°C)	140 psig -40°F(-40°C)	
Model 76-01	.3	.6	1	1.3	1.7	
Model 76-02	.7	1	2	2.6	3.4	
Model 76-10	3.3	5	10	13	17	
Model 76-20	6.6	10	20	26	34	
Model 76-40	13.2	20	40	52	68	
Model 76-100-4050	33	50	100	130	170	

Membrane Module Regeneration Flow		Regeneration Flow (SCFM) at Indicated Operating Pressure (psig) and all dewpoints				
Pressure Dewpoint	60 psig	80 psig	100 psig	120 psig	140 psig	
Model 76-01	.2	.2	.3	.3	.3	
Model 76-02	.34	.4	.5	.6	.7	
Model 76-10	1.7	2.1	2.5	3	3.5	
Model 76-20	3.4	4.2	5	6	7	
Model 76-40	6.8	8.4	10	12	14	
Model 76-100-4050	17	21	25	30	35	

Principal Specifications

Model	76-01	76-02	76-10	76-20	76-40	76-100-4050
Max. Flow Rate At -40°F (-40°C) Dewpoint (1)	1 SCFM	2 SCFM	10 SCFM	20 SCFM	40 SCFM	100 SCFM
Min/Max Inlet Air Temp. (2)	40°F/120°F (4°C/49°C)	→				
Ambient Temp. Range	40°F - 120°F (4°C - 49°C)	→				
Min/Max Inlet Pressure	60 psig/150 psig	→				
Compressed Air Requirement	Total Air Consumption: Regeneration Flow (above) + Outlet Flow Requirements (see tables on pg. 3)					
Max. Pressure Drop (3)	5 psid	5 psid	5 psid	5 psid	5 psid	5 psid
Wall Mountable	Yes	Yes	Yes	Yes	Yes	No
Prefilter (included) (4)	A912A-BX	A912A-BX	A915A-BX	75962-BX	A960-BX	15/80-DX, 15/80-BX
Inlet/Outlet Port Size	1/4" NPT (female)	1/4" NPT (female)	1/2" NPT (female)	1" NPT (female)	1 1/2" NPT (female)/ 3/4" NPT (female)	2" NPT (male)
Electrical Requirements	None	None	None	None	None	None
Dimensions	6"W x 22"H x 5"D (15cm x 58cm x 13cm)	6"W x 23"H x 5"D (15cm x 58cm x 13cm)	6"W x 37"H x 5"D (15cm x 94cm x 13cm)	12"W x 37"H x 7"D (30cm x 94cm x 18cm)	19"W x 39"H x 8"D (48cm x 99cm x 21cm)	51"W x 66"H x 28"D (129cm x 167cm x 71cm)
Shipping Weight	9 lbs. (4 kg)	10 lbs. (5 kg)	18 lbs. (9 kg)	20 lbs. (9 kg)	35 lbs. (16 kg)	550 lbs. (250 kg)

Notes:

1 Dewpoint specified for saturated inlet air at 100°F (38°C) and 100 psig. Outlet flows will vary slightly for other inlet conditions.

2 Inlet compressed air dewpoint must not exceed the ambient air temperature.
3 5 psid at -40°F (-40°C) dewpoint operating parameters.

4 If compressed air is extremely contaminated, a Balston Grade DX prefilter should be installed directly upstream from the membrane dryer.

Ordering Information

For Assistance, call toll-free at 1-800-343-4048 8AM to 5PM Eastern Time

Description	Model	Number				
Balston Membrane Air Dryer	76-01	76-02	76-10	76-20	76-40	76-100-4050
Replacement Prefilter Cartridges	100-12-BXE	100-12-BXE	100-18-BXE	150-19-BXE	200-35-BXE	200-80-DXE 200-80-BXE
Optional Additional Coalescing Prefilter	A912A-DX	A912A-DX	A915A-DX	75962-DX	A960-DX	15/80-DX
Replacement Filter Cartridges for Optional Prefilter	100-12-DXE	100-12-DXE	100-18-DXE	150-19-DXE	200-35-DXE	200-80-DXE
Pressure Regulator (0-130 psig) 1/2" NPT Ports	72-130	72-130	72-130	72-130	---	---
Differential Pressure Indicator Assembly	---	---	---	---	41-071(1)	---

(1) optional accessory



Operating costs are 35 - 40% less than a refrigerant air dryer*

No electricity required

State-of-the-art membrane technology

Guaranteed 35°F dewpoint - 13% dryer than refrigerant dryers

Durable - will hold up to the dirtiest compressed air system

No requirement for costly maintenance contracts

Output capacities to 1200 scfm *

Complete system with prefilters, autodrains, and pressure indicators



5000 Series SMART Dryer

The Only Way To Dry Compressed Air!

Now, there is only one sensible way to dry compressed air! High efficiency, durable membrane technology is quickly becoming the standard for drying compressed air. Parker Hannifin is leading the way with membrane technology that consumes the least amount of compressed air for drying.

The SMART Dryer™ utilizes sophisticated technology to monitor system parameters and automatically adjusts the regenerative sweep flow as required. The variable sweep system results in significant energy savings and low operating costs.

The SMART Dryer™ technology offers another advantage over refrigerant air drying technology as it does not produce condensate. An average 100 CFM compressor system can produce up to 1,800 gallons of oily condensate per year! The refrigerant dryer condenses it into an oily/water emulsion which has to be disposed of at a high cost to you! The Balston® Membrane Air Dryer is designed to operate continuously, 24 hours a day, 7 days a week. The only maintenance required is changing the prefilter cartridges twice a year, which take approximately 5 minutes and requires no tools!

Applications	Benefits
General Compressed Air Mainlines	Easy to install - no electrician required to install or maintain system No refrigerants or freons - environmentally friendly Complete system with prefilters, auto drains, and pressure gauges Compact size
Process Controls	
HVAC Systems	
Instrument Cabinets	
CNC/CMM Machinery	
Fire and Sprinkler Systems	
Pneumatic Controls	
Dry Air for Hazardous Areas	
Chemical Blanketing and Packaging	
Electronics/Dry Boxes	
Laser Optics	

*Non-cycling refrigerant air dryer

** Consult Factory



Why buy a Balston SMART Dryer™ instead of a cycling refrigerant air dryer?

The Balston SMART Dryer will save YOU money and offer better performance!

All Balston SMART Dryers require no electricity.

All air dryers are sized based on the maximum capacity output of a compressed air system with inlet conditions assumed to be 100°F inlet temperature, 100 psig inlet pressure and 100°F ambient temperature. In the majority of installations, it is unlikely air dryers will be required to operate under these extreme conditions. Most importantly, the majority of compressed air systems are not operating at the maximum output capacity.

Refrigerant and desiccant air dryers, sized to meet these operating conditions are designed to run continuously regardless of the systems demands, when in fact the actual system conditions are far less.

The result is significant operating costs in wasted energy and wear and tear on refrigerant compressors, cooling systems, drains and other componentry.

In a typical manufacturing plant operating one 8 hour shift with a 100 SCFM compressor system running at 75% capacity (on average over the 8 hour shift), a typical non-cycling refrigerant air dryer would cost \$716 in just electrical costs alone, compared to the Balston SMART Dryer with only \$436 in electrical costs. If you factor in the annual maintenance costs of \$600 for a non-cycling refrigerant dryer compared to \$130 for the Balston SMART Dryer, there is a total annual savings of over \$750.

Recently, refrigerant manufacturers have responded to this issue by developing a cycling air dryer which cools a cold storage heat sink reservoir. Once the reservoir is cooled to the minimum temperature the compressor (refrigerant) is shut off. The compressor cycles back on when the temperature of the storage reservoir reaches a preset upper limit. This reduces the total energy consumption of the dryer however it could produce significant variations in output dewpoints.

The Balston SMART Dryer does not require refrigerant, compressors, cooling systems or other componentry that carries high operating costs (energy) and maintenance costs. The Balston SMART Dryer utilizes sophisticated technology to monitor the system parameters and automatically adjusts the regenerative sweep flow as required. The variable sweep system results in significant energy savings and low operating costs with no fluctuation in output dewpoints.

In a typical manufacturing plant operating an 8 hour shift with 100 SCFM compressor system running at 75% capacity (on average over the 8 hour shift), a typical

cycling refrigerant air dryer would cost \$454.00 in electrical costs alone, compared to the Balston SMART Dryer with only \$436.00 in electrical costs. If you factor in the annual maintenance cost of \$800 for a cycling refrigerant dryer compared to \$130.00 for the Balston SMART Dryer, there is a total annual savings of over \$685.00

Additionally, there are no moving parts, no freons that need recharging, no compressors to be serviced and no cooling coils to be cored and cleaned.

Most importantly, the Balston SMART Dryer is producing a constant 35°F dewpoint which is 13% dryer than a cycling refrigerant air dryer (ppm weight in air).

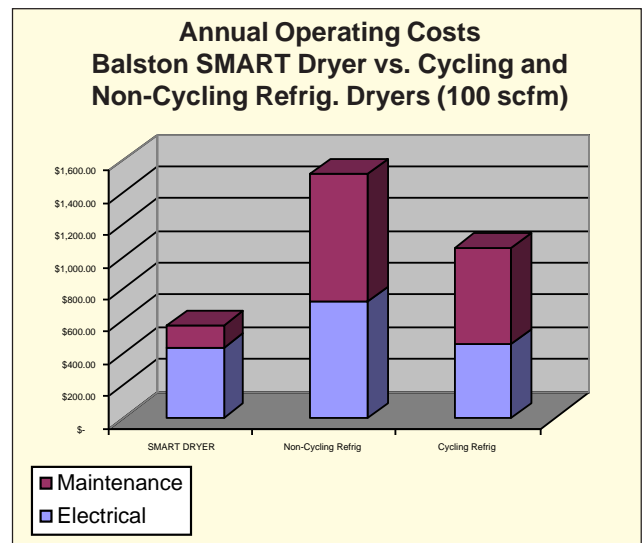

Here's What Our Customers Say

"Our compressed air system is now completely dry and clean at a very reasonable cost. And we gain at least three hours of production time each week by not having to shut down to clean rusted valves..."

Wayne Etchells, Vice President
Melton Corporation, Cranston, R.I.

"This new type of membrane dryer was just what we needed to eliminate problems with water building up in compressed air lines...Since the day we installed it, we haven't had a single problem with rust. The time and money we save by not having to repair spindles and air motors pays for the cost of the dryer every few months."

John Napier, Maintenance Engineer
King Machine, Akron, OH

Model SMRT5100
Front View

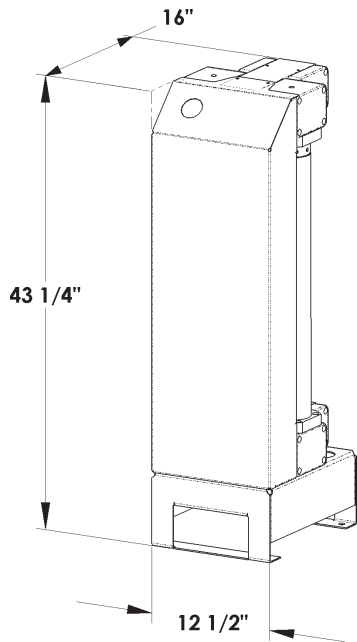

Model SMRT5200
Front View

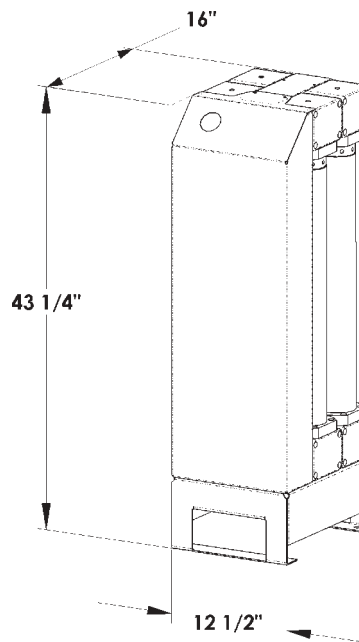

Principal Specifications

	Membrane Air Dryers	
Model Number	SMRT5100	SMRT5200
Max Flow Rate @35°F dewpoint	100 SCFM	200 SCFM
Dewpoint	35°F (2°C)	35°F (2°C)
Min/Max Inlet Air Temp.	40°F/120°F (4°C/49°C)	40°F/120°F (4°C/49°C)
Ambient Temp. Range	40°F/110°F (4°/43°C)	40°F/110°F (4°/43°C)
Min/Max Inlet Pressure	80 psig/150 psig (5.5 barg/10 barg)	80 psig/150 psig (5.5 barg/10 barg)
Max Dewpoint	120°F PDF	120°F PDF
Altitude	2000M	2000M
Max Compressed Air (1) Requirement	113 SCFM	226 SCFM
Max Pressure Drop (2)	10 psi (0.7 bar)	10 psi (0.7 bar)
Inlet/Outlet Port Size	1 1/2"NPT(male)	2"NPT(male)
Physical Dimensions (3)	12.5"w x 44"h x 18"d (32cm x 112cm x 46cm)	12.5"w x 44"h x 18"d (32cm x 112cm x 46cm)
Shipping Weight	175 lbs(86 kg)	175 lbs(100 kg)

Notes:

- 1 Dewpoint specified for saturated inlet air at 100°F(38°C) and max. flow at 100 psig. Outlet flow and dewpoint will vary for other inlet conditions.
- 2 Max. pressure drop measured at max flow rate @ 100 psig. Pressure drop will increase at lower feed pressures - consult factory.
- 3 Excluding coalescing prefilter assembly.

Ordering Information For assistance call 1-800-343-4048

Model Number	SMRT5100	SMRT5200
Coalescing Prefilter Assembly	2312N-1B1-DX 2312N-1B1-BX	A15/80-DX A15/80-BX
Replacement Prefilter Cartridges (every 6 months)	200-35-DXE 200-35-BXE	200-35-DXE 200-35-BXE
Membrane Replacement Module	D01-0086	D01-0086
Automatic Drain Kit	21552	21552

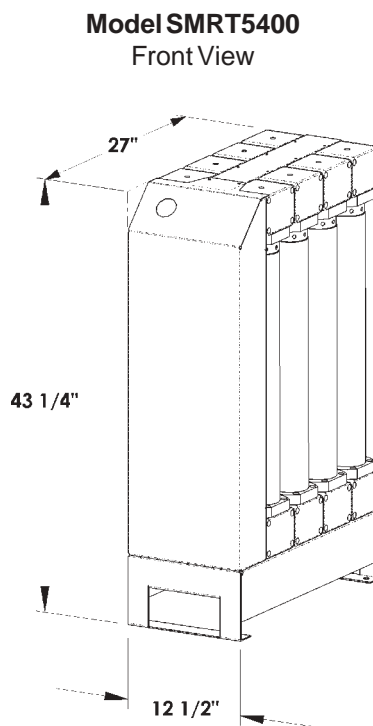
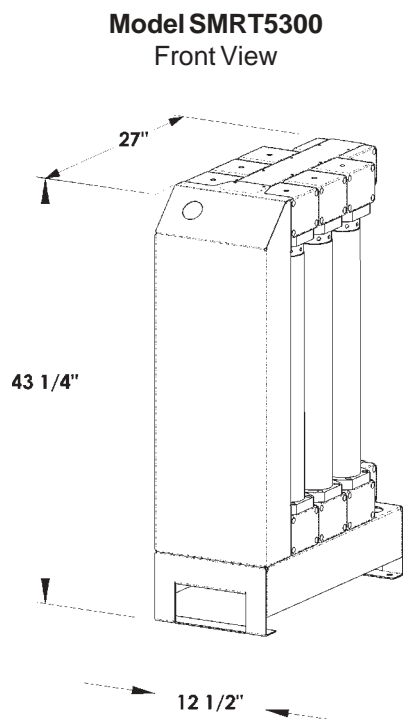

Principal Specifications		
Membrane Air Dryers		
Model Number	SMRT5300	SMRT5400
Max Flow Rate @35°F dewpoint	300 SCFM	400 SCFM
Dewpoint (1)	35°F (2°C)	35°F (2°C)
Min/Max Inlet Air Temp.	40°F/120°F (4°C/49°C)	40°F/120°F (4°C/49°C)
Ambient Temp. Range	40°F/110°F (4°/43°C)	40°F/110°F (4°/43°C)
Min/Max Inlet Pressure	80 psig/150 psig (5.5 barg/10 barg)	80 psig/150 psig (5.5 barg/10 barg)
Max Inlet Dewpoint	120°F PDP	120°F PDP
Altitude	2000M	2000M
Max Compressed Air Requirement (1)	339 SCFM	452 SCFM
Max Pressure Drop (2)	10 psi (0.7 bar)	10 psi (0.7 bar)
Inlet/Outlet Port Size	2"NPT(male)	2"NPT(male)
Physical Dimensions (3)	32"w x 112"h x 74"d	32"w x 112"h x 74"d
Shipping Weight	300 lbs	375 lbs

Notes:

- 1 Dewpoint and maximum flow specified for saturated inlet air at 100°F(38°C) at 100 psig. Outlet flow and dewpoint will vary for other inlet conditions.
- 2 Max. pressure drop measured at max flow rate @ 100 psig. Pressure drop will increase at lower feed pressures - consult factory.
- 3 Excluding coalescing prefilter assemblies.

Ordering Information For assistance call 1-800-343-4048		
Model Number	SMRT5300	SMRT5400
Coalescing Prefilter Assembly	C02-2356 C02-2357	C02-2358 C02-2359
Replacement Prefilter Cartridges (every 6 months)	210-800-DXE 210-800-BXE	210-955-DXE 210-955-BXE
Membrane Module	D01-0086	D01-0086
Automatic Drain Kit	21552	21552



Model SMRT5500
Front View

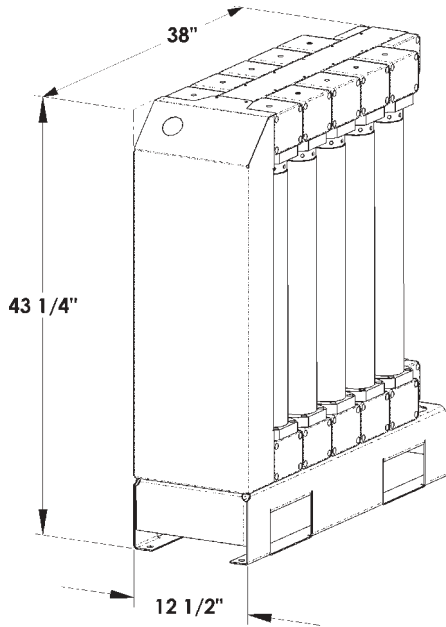

Model SMRT5600
Front View

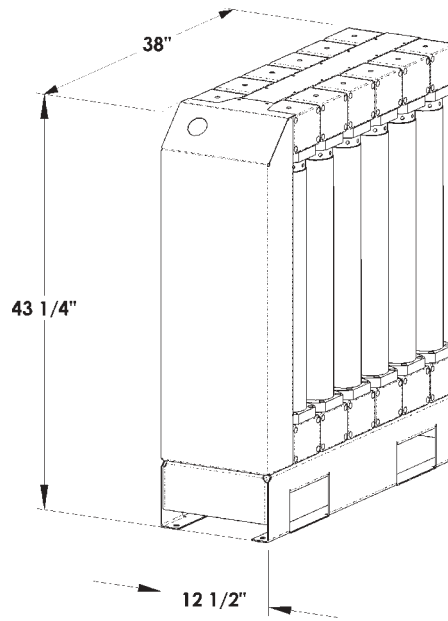

Principal Specifications

Model Number	Membrane Air Dryers	
	SMRT5500	SMRT5600
Max Flow Rate @35°F dewpoint	500 SCFM	600 SCFM
Dewpoint (1)	35°F (2°C)	35°F (2°C)
Min/Max Inlet Air Temp.	40°F/120°F (4°C/49°C)	40°F/120°F (4°C/49°C)
Ambient Temp. Range	40°F/110°F (4°/43°C)	40°F/110°F (4°/43°C)
Min/Max Inlet Pressure	80 psig/150 psig (5.5 barg/10 barg)	80 psig/150 psig (5.5 barg/10 barg)
Max Relative Dewpoint	120°F PDP	120°F PDP
Altitude	2000M	2000M
Max Compressed Air Requirement (1)	565 SCFM	678 SCFM
Max Pressure Drop	10 psi (0.7 bar)	10 psi (0.7 bar)
Inlet/Outlet Port Size	2 1/2"NPT	3"NPT
Physical Dimensions	32"w x 112"h x 102"d	32"w x 112"h x 102"d
Shipping Weight	475 lbs	550 lbs

Notes:

- 1 Dewpoint and maximum flow specified for saturated inlet air at 100°F(38°C) at 100 psig. Outlet flow and dewpoint will vary for other inlet conditions.
- 2 Max. pressure drop measured at max flow rate @ 100 psig. Pressure drop will increase at lower feed pressures - consult factory.
- 3 Excluding coalescing prefilter assemblies.

Ordering Information For assistance call 1-800-343-4048

Model Number	SMRT5500	SMRT5600
Coalescing Prefilter Assembly	C02-2360 C02-2361	C02-2362 C02-2363
Replacement Prefilter Cartridges (every 6 months)	300-960-DXE 300-960-BXE	300-960-DXE 300-960-BXE
Membrane Module	D01-0086	D01-0086
Automatic Drain Kit	21552	21552

Membrane Air Dryers for Coordinate Measurement Machines



Protects CMMs from costly repairs caused by oil and water

Guaranteed dewpoint of 35°F

Offers a reliable, efficient, and economical alternative to PSA and refrigerant dryer technologies

Ideal for supplying pure, dry air to Starrett, Brown & Sharpe, Zeiss, and MTI CMMs

Requires no electricity resulting in lower operating costs

Silent operation

No desiccant to change

Problems that cause costly repairs to Coordinate Measurement Machines

A CMM has 26 highly sensitive air bearings per machine. If oil and moisture are present in the air system supplying the air bearings, the .5mm hole in the bottom of the air bearing will become clogged producing a "drag" in the machine. As the resistance builds, it causes hysteresis in the measurements producing an inaccurate measurement.

If this problem is allowed to continue, the bearing will drag on the aluminum ways and wear a groove in the machine. Once a groove develops, the air bearing will not produce lift if air is leaking out through the groove in the machine ways. To correct the problem, a complete rebuild of the machine at the factory is necessary which can be as costly as purchasing a new machine.

If the problem is caught in time, a service team will be required to come to the facility to repair the machine. The team will remove the bearings and the holes and grooves are cleaned with alcohol. Each bearing is then resurfaced with 600-1500 grit paper. Badly corroded or pitted air bearings are replaced at a cost of \$200.00 per bearing. Air hoses

are also replaced, and all air passages are cleaned. The machine is then reassembled, and the time-consuming and costly task of recalibrating the machine with the ball bar and B89 test is performed as the final step in repairing the machine.

How to avoid costly maintenance problems

Many repairs average upwards of \$5,000.00. These costly repairs and downtime can easily be avoided by installing a Balston high efficiency Membrane Air Dryer. The Balston Membrane Air Dryer will provide extremely clean, dry air to a CMM, eliminating the possibility of contamination. The Dryer utilizes patented membrane technology, unsurpassed in performance and durability to dehydrate and purify the compressed air. The Balston Membrane Dryer is the only system designed specifically for CMM applications.



SMART Dryer™ 5000 Series Membrane Air Dryers For Coordinate Measurement Machines

Membrane Air Dryers for Coordinate Measurement Machines

Flow Rates	Outlet Flow (SCFM) at Indicated Operating Pressure (psig)										
	Pressure Dewpoint	60 psig		80 psig		100 psig		120 psig		140 psig	
		-40°F(40°C)	32°F (0°C)	-40°F(40°C)	32°F (0°C)	-40°F(40°C)	32°F (0°C)	-40°F(40°C)	32°F (0°C)	-40°F(40°C)	32°F (0°C)
Model 76-25-3560		25		25		25		---		---	
Model 76-25-3500		---		---		---		25		25	

Principal Specifications

Model	76-25-XX
Max. Flow Rate at 35°F (2°C) Dewpoint (1)	25 SCFM
Min/Max Inlet Air Temp. (2)	40°F/100°F (4°C/38°C)
Ambient Temp. Range	40°F/100°F (4°C/38°C)
Min/Max Inlet Pressure	60 psig / 140 psig
Compressed Air Requirement	28 SCFM
Max. Pressure Drop	6 psi
Prefilter	76-915-DX, 76-915-BX
Inlet/Outlet Port Size	1/2" NPT (male)
Electrical Requirements	None
Dimensions	18"W X 33"H X 13"D (45cmX85cmX32cm)
Shipping Weight	65 lbs. (30 kg)

Notes:

1 Dewpoint specified for inlet air at 100°F (38°C) and 100 psig (The Compressed air & Gas Institute Standard for Testing and Rating compressed air dryers) Outlet dewpoint will vary slightly for inlet air > 100°F (38°C) conditions. Outlet dewpoint will vary with operating pressures other than 100 psig. Consult factory.
2 Inlet compressed air dewpoint must

not exceed the ambient air temperature.
3 Compressed air is extremely contaminated, an aftercooler and separator must be installed directly upstream from the membrane dryer. Consult factory for recommendation.
4 Pressures from 101 PSIG to 140 PSIG.
5 Pressures from 60 PSIG to 100 PSIG.

Ordering Information

For Assistance, call toll-free at 1-800-343-4048 8AM to 5PM Eastern Time

Description	Model Number
Balston Membrane (5)	76-25-3500
Air Dryer (6)	76-25-3560
Replacement Prefilter Cartridges (4)	
First Stage	100-18-DXE
Second Stage	100-18-BXE



Balston
Compressed Air
Dryer

Applications

Pneumatic Tool Stations
 HVAC Systems
 Purge Electrical Boxes
 Air Lines Subject to Sub-Freezing
 Temperatures
 Blanketing Moisture Sensitive Materials
 Spray Painting
 Pneumatic Instrumentation
 Robotics
 Lasers
 Dry Boxes

**Reduce the dewpoint of compressed air
to -100°F (-73°C)**

Unattended 24 hour operation

Lightweight and compact

No desiccant to change

Model 75-20

Balston regenerative PSA desiccant dryers reduce the atmospheric dewpoint of compressed air without operator attention. Model 75-20 will reduce the dewpoint to -100°F (-73°C). Each dryer is delivered complete and ready for easy installation. Each model has coalescing prefilters, PSA drying towers, automatic drains, a particulate final filter, a moisture indicator, differential pressure indicator, and pretested controls.

Balston regenerative dryers have safe, 12 VDC electrical controls. To install, simply attach the inlet (60 psig minimum) and outlet air lines, plug the electrical transformer into a wall outlet - no electrician required - and the unit is ready for trouble-free operation.

These reliable dryers can be easily installed, operated, and maintained by personnel not trained in instrumentation. In addition to supplying analytical instruments with dry, particulate-free air, the Balston dryers are useful when air comes into contact with moisture-sensitive materials, or when outside compressed air lines are subjected to sub-freezing temperatures.

The 75-20 is a wall mountable unit. It has a 10 SCFM/min. capacity (at 100 psig inlet pressure).

Principal Specifications

Model	75-20
Dewpoint (1)	-100°F (-73°C)
Max. Dry (outlet) Air Flow Rate for Specified Dew Point (1)	
Inlet Pressure 125 psig	12.0 SCFM (340 lpm)
Inlet Pressure 100 psig	10.0 SCFM (283 lpm)
Inlet Pressure 80 psig	8.3 SCFM (235 lpm)
Inlet Pressure 60 psig	6.5 SCFM (184 lpm)
Air Loss for Regeneration (2)	2.5 SCFM (71 lpm)
Min/Max Inlet Air Pressure	60 psig/125 psig
Max. Inlet Air Temperature (3)	78°F (25°C)
Pressure Drop at Max. Flow Rate	8 psi
Inlet/Outlet Port Size (female)	1/4" NPT
Electrical Requirements (4)	120 VAC/60 Hz.
Shipping Weight	50 lbs. (23 kg)
Dimensions	15"W X 41"H (38cm X 104cm)

Notes:

1 Dewpoint will be lower than specified at lower air flow.

2 Total air required = air loss for regeneration + process demand (up to max. dry air flow rate).

3 Outlet dewpoint will increase at higher inlet compressed air temperatures.

4 Power consumption - less than 10 watts. Each dryer is shipped with a 12 VDC plug-in transformer to connect to the local electrical supply.

Ordering Information

For Assistance, call toll-free at 1-800-343-4048 8AM to 5PM Eastern Time

Description	Model Number
Balston Compressed Air Dryer	75-20
Replacement Filter Cartridges 1st stage (box of 10)	100-18-DXE
Replacement Filter Cartridges 2nd stage (box of 10)	100-18-BXE
Maintenance Kit, 1 year supply of filter cartridges	MK7525



Offer of Sale

The items described in this document are hereby offered for sale at prices to be established by Parker Hannifin Corporation, its subsidiaries and its authorized distributors. This offer and its acceptance by any customer ("Buyer") shall be governed by all of the following Terms and Conditions. Buyer's order for any item described in its document, when communicated to Parker Hannifin Corporation, its subsidiary or an authorized distributor ("Seller") verbally or in writing, shall constitute acceptance of this offer.

1. Terms and Conditions of Sale: All descriptions, quotations, proposals, offers, acknowledgments, acceptances and sales of Seller's products are subject to and shall be governed exclusively by the terms and conditions stated herein. Buyer's acceptance of any offer to sell is limited to these terms and conditions. Any terms or conditions in addition to, or inconsistent with those stated herein, proposed by Buyer in any acceptance or an offer by Seller, are hereby objected to. No such additional, different or inconsistent terms and conditions shall become part of the contract between Buyer and Seller unless expressly accepted in writing by Seller. Seller's acceptance of any offer to purchase by Buyer is expressly conditional upon Buyer's assent to all the terms and conditions stated herein, including any terms in addition to, or inconsistent with those contained in Buyer's offer. Acceptance of Seller's products shall in all events constitute such assent.

2. Payment: Payment shall be made by Buyer within 30 days from the date of shipment. Amounts not timely paid shall bear interest at the maximum rate permitted by law for each month or portion thereof that the Buyer is late making payment. Any claims by Buyer for omissions or shortages in a shipment shall be waived unless Seller receives notice thereof within 30 days after Buyer's receipt of the shipment.

3. Delivery: Unless otherwise provided on the face hereof, delivery shall be made F.O.B. Seller's plant. Regardless of the method of delivery, however, risk of loss shall pass to Buyer upon Seller's delivery to a carrier. Any delivery dates shown are approximate only and Seller shall have no liability for any delays in delivery.

4. Warranty: Seller warrants that the items sold hereunder shall be free from defects in material or workmanship for a period of 12 months from date of shipment to Buyer. THIS WARRANTY COMPRISES THE SOLE AND ENTIRE WARRANTY PERTAINING TO ITEMS PROVIDED HEREUNDER. SELLER MAKES NO OTHER WARRANTY, GUARANTEE, OR REPRESENTATION OF ANY KIND WHATSOEVER. ALL OTHER WARRANTIES, INCLUDING BUT NOT LIMITED TO, MERCHANTABILITY AND FITNESS FOR PURPOSE, WHETHER EXPRESS, IMPLIED, OR ARISING BY OPERATION OF LAW, TRADE USAGE, OR COURSE OF DEALING ARE HEREBY DISCLAIMED.

NOTWITHSTANDING THE FOREGOING, THERE ARE NO WARRANTIES WHATSOEVER ON ITEMS BUILT OR ACQUIRED WHOLLY OR PARTIALLY, TO BUYER'S DESIGNS OR SPECIFICATIONS.

5. Limitation of Remedy: SELLER'S LIABILITY ARISING FROM OR IN ANY WAY CONNECTED WITH THE ITEMS SOLD OR THIS CONTRACT SHALL BE LIMITED EXCLUSIVELY TO REPAIR OR REPLACEMENT OF ITEMS SOLD OR REFUND OF THE PURCHASE PRICE PAID BY BUYER, AT SELLER'S SOLE OPTION. IN NO EVENT SHALL SELLER BE LIABLE FOR ANY INCIDENTAL, CONSEQUENTIAL OR SPECIAL DAMAGES OF ANY KIND OR NATURE WHATSOEVER, INCLUDING BUT NOT LIMITED TO LOST PROFITS ARISING FROM OR IN ANY WAY CONNECTED WITH THIS AGREEMENT OR ITEMS SOLD HEREUNDER, WHETHER ALLEGED TO ARISE FROM BREACH OF CONTRACT, EXPRESS OR IMPLIED WARRANTY, OR IN TORT, INCLUDING WITHOUT LIMITATION, NEGLIGENCE, FAILURE TO WARN OR STRICT LIABILITY.

6. Changes, Reschedules and Cancellations: Buyer may request to modify the designs or specifications for the items sold hereunder as well as the quantities and delivery dates thereof, or may request to cancel all or part of this order, however, no such requested modification or cancellation shall become part of the contract between Buyer and Seller unless accepted by Seller in a written amendment to this agreement. Acceptance of any such requested modification or cancellation shall be at Seller's discretion, and shall be upon such terms and conditions as Seller may require.

7. Special Tooling: A tooling charge may be imposed for any special tooling, including without limitation, dies, fixtures, molds and patterns, acquired to manufacture items sold pursuant to this contract. Such special tooling shall be and remain Seller's property notwithstanding payment of any charges by Buyer. In no event will Buyer acquire any interest in apparatus belonging to Seller which is utilized in the manufacture of the items sold hereunder, even if such apparatus has been specially

converted or adapted for such manufacture and notwithstanding any charges paid by Buyer. Unless otherwise agreed, Seller shall have the right to alter, discard or otherwise dispose of any special tooling or other property in its sole discretion at any time.

8. Buyer's Property: Any designs, tools, patterns, materials, drawings, confidential information or equipment furnished by Buyer or any other items which become Buyer's property, may be considered obsolete and may be destroyed by Seller after two (2) consecutive years have elapsed without Buyer placing an order for the items which are manufactured using such property. Seller shall not be responsible for any loss or damage to such property while it is in Seller's possession or control.

9. Taxes: Unless otherwise indicated on the face hereof, all prices and charges are exclusive of excise, sales, use, property, occupational or like taxes which may be imposed by any taxing authority upon the manufacture, sale or delivery of the items sold hereunder. If any such taxes must be paid by Seller or if Seller is liable for the collection of such tax, the amount thereof shall be in addition to the amounts for the items sold. Buyer agrees to pay all such taxes or to reimburse Seller therefore upon receipt of its invoice. If Buyer claims exemption from any sales, use or other tax imposed by any taxing authority, Buyer shall save Seller harmless from and against any such tax, together with any interest or penalties thereon which may be assessed if the items are held to be taxable.

10. Indemnity For Infringement of Intellectual Property Rights: Seller shall have no liability for infringement of any patents, trademarks, copyrights, trade dress, trade secrets or similar rights except as provided in this Part 10. Seller will defend and indemnify Buyer against allegations of infringement of U.S. patents, U.S. trademarks, copyrights, trade dress and trade secrets (hereinafter 'Intellectual Property Rights'). Seller will defend at its expense and will pay the cost of any settlement or damages awarded in an action brought against Buyer based on an allegation that an item sold pursuant to this contract infringes the Intellectual Property Rights of a third party. Seller's obligation to defend and indemnify Buyer is contingent on Buyer notifying Seller within ten (10) days after Buyer becomes aware of such allegations of infringement, and Seller having sole control over the defense of any allegations or actions including all negotiations for settlement or compromise. If an item sold hereunder is subject to a claim that it infringes the Intellectual Property Rights of a third party, Seller may, at its sole expense and option, procure for Buyer the right to continue using said item, replace or modify said item so as to make it noninfringing, or offer to accept return of said item and return the purchase price less a reasonable allowance for depreciation. Notwithstanding the foregoing, Seller shall have no liability for claims of infringement based on information provided by Buyer, or directed to items delivered hereunder for which the designs are specified in whole or part by Buyer, or infringements resulting from the modification, combination or use in a system of any item sold hereunder. The foregoing provisions of this Part 10 shall constitute Seller's sole and exclusive liability and Buyer's sole and exclusive remedy for infringement of Intellectual Property Rights.

If a claim is based on information provided by Buyer or if the design for an item delivered hereunder is specified in whole or in part by Buyer, Buyer shall defend and indemnify Seller for all costs, expenses or judgments resulting from any claim that such item infringes any patent, trademark, copyright, trade dress, trade secret or any similar right.

11. Force Majeure: Seller does not assume the risk of and shall not be liable for delay or failure to perform any of Seller's obligations by reason of circumstances beyond the reasonable control of Seller (hereinafter 'Events of Force Majeure'). Events of Force Majeure shall include without limitation, accidents, acts of God, strikes or labor disputes, acts, laws, rules or regulations of any government or government agency, fires, floods, delays or failures in delivery of carriers or suppliers, shortages of materials and any other cause beyond Seller's Control.

12. Entire Agreement/Governing Law: The terms and conditions set forth herein, together with any amendments, modifications and any different terms or conditions expressly accepted by Seller in writing, shall constitute the entire Agreement concerning the items sold, and there are no oral or other representations or agreements which pertain thereto. This Agreement shall be governed in all respects by the law of the State of Ohio. No actions arising out of the sale of the items sold hereunder or this Agreement may be brought by either party more than two (2) years after the cause of action accrues.

Application Notes

Application Notes



Parker Hannifin Corporation
 Filtration and Separation Division
 242 Neck Road, P.O. Box 8223
 Haverhill, MA 01835-0723
 Phone: 800-343-4048 or 978-858-0505
 Fax: 978-858-0625
<http://www.parker.com/balston>

Parker Hannifin Corporation

About Parker Hannifin Corporation

Parker Hannifin is a leading global motion-control company dedicated to delivering premier customer service. A Fortune 500 corporation listed on the New York Stock Exchange (PH), our components and systems comprise over 1,400 product lines that control motion in some 1,000 industrial and aerospace markets. Parker is the only manufacturer to offer its customers a choice of hydraulic, pneumatic, and electromechanical motion-control solutions. Our Company has the largest distribution network in its field, with over 7,500 distributors serving nearly 400,000 customers worldwide.

Parker's Charter

To be a leading worldwide manufacturer of components and systems for the builders and users of durable goods. More specifically, we will design, market and manufacture products controlling motion, flow and pressure. We will achieve profitable growth through premier customer service.

Product Information

North American customers seeking product information for Balston products, the location of local sales offices or repair services will receive prompt attention by calling the Filtration and Separation Division at our toll-free number: 1-800-343-4048. For all other product information call 1-800-C-PARKER (1-800-272-7537).

The Aerospace Group is a leader in the development, design, manufacture and servicing of control systems and components for aerospace and related high-technology markets, while achieving growth through premier customer service.



The Climate & Industrial Controls Group designs, manufactures and markets system-control and fluid-handling components and systems to refrigeration, air-conditioning and industrial customers worldwide.



The Fluid Connectors Group designs, manufactures and markets rigid and flexible connectors, and associated products used in pneumatic and fluid systems.



The Seal Group designs, manufactures and distributes industrial and commercial sealing devices and related products by providing superior quality and total customer satisfaction.



The Hydraulics Group designs, produces and markets a full spectrum of hydraulic components and systems to builders and users of industrial and mobile machinery and equipment.



The Filtration Group designs, manufactures and markets quality filtration and clarification products, providing customers with the best value, quality, technical support, and global availability.



The Automation Group is a leading supplier of pneumatic and electromechanical components and systems to automator customers worldwide.



The Instrumentation Group is a global leader in the design, manufacture and distribution of high-quality critical flow components for worldwide process instrumentation, ultra-high-purity, medical and analytical applications.



Filtration Group Technical Sales & Service Locations

Filtration Group North America

Filtration and Separation Division
242 Neck Road, P.O. Box 8223
Haverhill, MA 01835-0723
Phone: 800-343-4048 or 978-858-0505
Fax: (978) 858-0625

Haverhill, MA
Phone: (978) 858-0505

Baltimore, MD
Phone: (410) 636-7200

Oxford, MI
Phone: (248) 628-6400

Hydraulic Filter Division
16810 Fulton County Road #2
Metamora, OH 43540-9714
Phone: (419) 644-4311
Fax: (419) 644-6205

Process Filtration Division
6640 Intech Boulevard
Indianapolis, IN 46278
Phone: (317) 275-8300
Fax: (317) 275-8413

Tell City, IN
Phone: (812) 547-2371

Racor Division
3400 Finch Road
P.O. Box 3208
Modesto, CA 95353
Phone: (800) 344-3286
Phone: (209) 521-7860
Fax: (209) 529-3278

Beaufort, SC
Phone: (843) 846-3200

Henryetta, OK
Phone: (800) 451-7299

Holly Springs, MS
Phone: (662) 252-2656

Filter Division Europe
Parker Hannifin UK Ltd.
Shaw Cross Business Park
Dewsbury, West Yorkshire
England WF12 7RD UK
Phone: +44 (0) 1924 487000
Fax: +44 (0) 1924 487001

Arnhem
The Netherlands
Phone: +31 (0) 26 3760376

Etten-Leur
The Netherlands
Phone: +31 76 508 53 00

Maidstone
England
Phone: +44 (0) 1622 723300

Thetford, Norfolk
England
Phone: +44 (0) 1842 763299

Urdala As.
Finland
Phone: +358 (0)3 54100

Filtration Group Asia Pacific

Parker Hannifin Asia Pacific Company, LTD
Filtration Group
Dae Venture Plaza
169 Samsung-Dong
Kangnam-Ku, Seoul
Korea 135-882
Phone: +82 2 559 0400
Fax: +82 2 556 8187

Filtration Group Latin America

Parker Hannifin Ind. e Com. Ltda. Filter Division
AV Getulio Vargas, 1331/1333
123-05-000 Jacarei, SP
Brazil
Phone: +55 (11) 3917 1222
Fax: +55 (11) 3917 1102

Call 1-800-343-4048
for any Parker Products
In Europe, 00800-2727-5374
or visit our Web site
www.parker.com/balston

Parker Worldwide Sales Offices

Contact Parker's worldwide service and distribution network by calling:

Argentina	+54 (11) 4752 4129	Hong Kong	+852 (2) 428 8008	Singapore	+65 6261 5233
Australia	+61 (2) 9 634 7777	Hungary	+36 (1) 252 8137	South Africa	+27 (11) 392 7280
Austria	43-2622-23501-0	India	91-22-790-7081	Spain	+34 (91) 675 7300
Belgium	+32 (67) 280900	Italy	39-02-451921	Sweden	46-8-5979-5000
Brazil	55-12-3955-1000	Japan	81-3-6408-3900	Switzerland	41-0-22-307-7111
Canada	1-800-272-7537	Jordan	(962) (6) 810679	Taiwan	+886 (2) 2298 8987
Central & South		Korea Choongnam	82-41-583-1410	Thailand	+662 693 3304
America/Caribbean ...	1-305-470-8800	Korea Kyoungnam	82-55-389-0100	United Arab Emirates .	971-2-6788587
China	+86 (21) 6445 9339	Korea Seoul	82-2-559-0420	United Kingdom	+44 (0) 1924-487000
Czech Republic	42-0-2-830-85-221	Mexico	1-800-272-7537	USA	1-800-272-7537
Denmark	45-0-43-56-04-00	Netherlands	31-0-541-585000	Venezuela	58-212-238-54-22
Finland	+358 (0)3 54100	New Zealand	+64 (9) 573 1523		
France	33-0-254-741403	Norway	47-64-91-1000		
Germany	49-0-2131-513-350	Poland	48-22-863-4942		

Note: The (+) sign in front of the country code indicates that you may need to dial an additional prefix.



Parker Hannifin Corporation
Filtration and Separation Division
242 Neck Road, P.O. Box 8223
Haverhill, MA 01835-0723
Phone: 800-343-4048 or 978-858-0505
Fax: 978-858-0625

<http://www.parker.com/balston>
Bulletin FNS 1A Printed June 2004
Copyright © Parker Hannifin Corporation 2004

Global Filtration
Technology

